



aquatherm blue pipe

Pipe system

For heating and cooling and various industrial applications



aquatherm

state of the pipe



NEW SINCE THE LAST VERSION

Page	Change
------	--------

–	Article Number Overhaul.
---	--------------------------

The application pictures in this catalogue show the aquatherm blue pipe pipes as they were produced until March 2020. With the material change to fusiolen® PP-RCT, the pipes are now single-coloured blue.

TABLE OF CONTENTS

Service	4	Installation principles	
Product overview	6	Fastening technique/Fixed points/Sliding points	70
Short cuts & symbols	8	Installation advice/Linear expansion/Concealed installation	70
Systems & features		Installation in ducts	71
aquatherm polypropylene pipe systems	10	Open installation/Calculation of the linear expansion	72
aquatherm blue pipe	11	Linear expansion	73
aquatherm blue pipe MF (composite technology)	14	Pipe clamps	75
aquatherm blue pipe ot	15	Bending side	76
aquatherm blue pipe ti	16	Expansion loop/Pre-stress/Bellow expansion joint	77
UV-resistance	20	Length of bending side	78
Integration of other systems or components	20	Length of bending side with pre-stress	79
Permissible working pressure	21	Support intervals	80
Fire protection	22	Thermal insulation of hot water pipes	81
Connection	26	Insulation thickness	82
Material: fusiolen®	27	Pressure test	83
aquatherm & ecology	28	Pressure test – test record	85
Environmental Product Declaration and LEED certification	29	Planning	
Quality assurance		Coefficient of loss	87
Compliance with the system standard/Quality management	30	Planning & design of compressed air applications	89
System control/Internal control	31	Chemical resistance	90
External control	33	Warranty	102
Application areas		References	104
Heating and air-conditioning	34	Transport and storage	121
Building services	35		
Industrial floor heating	36		
Ship building	37		
Under soil heating	38		
Ice surface cooling	39		
Compressed air/Swimming pool	40		
Agriculture/Special applications	41		
Fusion: Welding technology			
Part A: Tools and accessoires	42		
Part A: Assembly of welding tools	43		
Part A: Heating up phase/handling	44		
Guidelines			
Part B: Checking of devices and tools	45		
Preparation for the fusion			
Part B: Heating of pipe and fitting	46		
Setting and alignment			
Part B: Universal peeling tools	47		
Part C: Weld-in saddles	49		
Part C: Weld-on saddles: Drilling under pressure	52		
Part D: Welding jig (hitch)	53		
Part E: Welding machines	56		
Part F: Electrofusion device	57		
Push-fit fitting	60		
Flange connections	64		
Repair options	65		
Part G: Butt-welding	66		
Visual inspection of fusion seam	68		

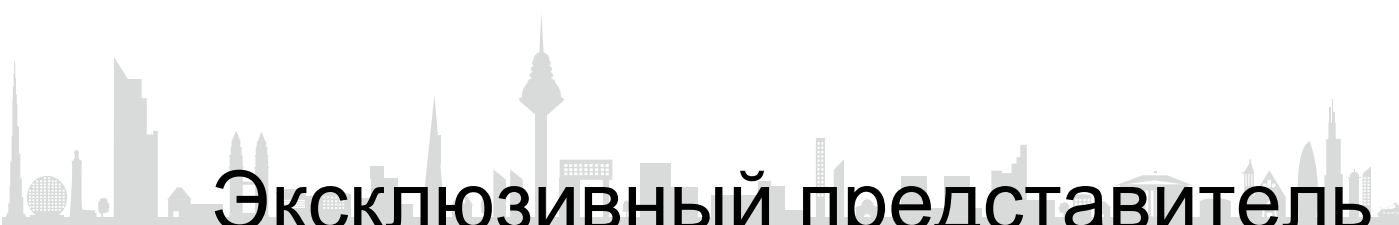

Эксклюзивный представитель

+7 (495) 928-0008

info@agpipe.ru

| www.agpipe.ru



Будь то инструктаж на строительной площадке, консультации по системам aquatherm у Вас, наши техники-консультанты ежедневно в пути по всему миру. Список наших представителей во всем мире вы найдете на нашей странице www.aquatherm.de в рубрике "Service"



В качестве дополнительного сервиса наряду с уже зарекомендовавшими себя тематическими докладами, или обучение специалистов на предприятии? aquatherm предлагает бесплатное обучение и информационные семинары в своих учебных центрах в г.Аттендори и г.Радеберг.

Компания aquatherm представляет свои стенды почти на всех отраслевых выставках, касающихся водоснабжения и отопления, как внутри страны, так и зарубежом. Информацию о точных датах проведения выставок Вы найдете на нашей странице www.aquatherm.de

Certifications in accordance with ISO 9001, 14001 & 50001

Since 1996 aquatherm fulfills the requirements of the quality management system according to DIN ISO 9001. The 2012 TÜV certificate was extended by the environmental management system according to ISO 14001 and currently by the energy management system according to ISO 50001.

This success is another step towards strengthening our competitive position and to meet the high requirements and the responsibility for our customers, partners and the environment.



Laboratory

From testing of granulate properties to permanent process monitoring: Only perfect goods have the chance to leave aquatherm.



Software service

The aquatherm software service provides Datanorm files, BIM-compatible files, an independent graphical configuration program (liNear) as well as the appropriate training on site.



Brochures and more

No matter whether brochures, catalogues or product lists are concerned: Everything is developed by our in-house marketing department. All documents can be downloaded as PDF from our website www.aquatherm.de. For printed copies just send an e-mail to infoservice@aquatherm.de.

SERVICE

PRODUCTS

aquatherm is the leading manufacturer of polypropylene pipe systems for plant engineering and building services. The numerous product lines provide superior solutions in potable water applications, heating systems, fire sprinkler systems, air-conditioning and refrigeration technology, as well as in surface heating and cooling systems. The product range comprises almost 17,000 articles in six product lines.

		Dimension [mm]																	
		16	17	20	25	32	40	50	63	75	90	110	125	160	200	250	315	355	400
aquatherm green pipe	SDR 6 S	●		●	●	●	●	●	●	●	●	●							
aquatherm green pipe	SDR 7.4 S	●		●	●	●	●	●	●										
aquatherm green pipe	SDR 7.4 MF			●	●	●	●	●	●	●	●	●	●	●	●	●			
aquatherm green pipe	SDR 7.4 MF UV			●	●	●	●	●	●	●	●	●	●	●	●	●			
aquatherm green pipe	SDR 9 MF RP					●	●	●	●	●	●	●	●	●	●	●	●	●	
aquatherm green pipe	SDR 9 MF RP UV					●	●	●	●	●	●	●	●	●	●	●	●	●	
aquatherm green pipe	SDR 9 MF RP TI					●	●	●	●	●	●	●	●	●	●	●	●	●	
aquatherm green pipe	SDR 11 S			●	●	●	●	●	●	●	●	●	●	●	●	●	●	●	
aquatherm green pipe	SDR 11 MF																		●
aquatherm blue pipe	SDR 7.4 MF			●	●														
aquatherm blue pipe	SDR 7.4 MF UV			●	●														
aquatherm blue pipe	SDR 7.4 MF OT			●	●														
aquatherm blue pipe	SDR 9 MF RP					●													
aquatherm blue pipe	SDR 9 MF RP UV					●													
aquatherm blue pipe	SDR 9 MF RP OT					●													
aquatherm blue pipe	SDR 9 MF RP TI					●													
aquatherm blue pipe	SDR 9 MF RP OT TI					●													
aquatherm blue pipe	SDR 11 S			●	●														
aquatherm blue pipe	SDR 11 MF RP						●	●	●	●	●	●	●	●	●	●	●	●	●
aquatherm blue pipe	SDR 11 MF RP UV						●	●	●	●	●	●	●	●	●	●	●	●	●
aquatherm blue pipe	SDR 11 MF RP OT						●	●	●	●	●	●	●	●	●	●			
aquatherm blue pipe	SDR 11 MF RP TI						●	●	●	●	●	●	●	●	●	●	●	●	
aquatherm blue pipe	SDR 11 MF RP OT TI						●	●	●	●	●	●	●	●	●	●			
aquatherm blue pipe	SDR 17.6 MF RP												●	●	●	●	●	●	●
aquatherm blue pipe	SDR 17.6 MF RP UV												●	●	●	●	●	●	●
aquatherm blue pipe	SDR 17.6 MF RP TI												●	●	●	●	●	●	●
aquatherm red pipe	SDR 7.4 MF HI					●	●	●	●	●	●	●	●						
aquatherm black system	M OT																		
aquatherm orange system	M OT	●	●	●	●														
aquatherm grey pipe	M OT	●		●	●														

SHORT CUTS & SYMBOLS

Abbreviations pipe structure	
S	single-layer
M	multi-layer
MF	multi-layer, fibre-reinforced
RP	raised pressure resistance
UV	UV-resistant
OT	oxygen-tight
TI	thermally isolated

Abbreviations material	
PP	polypropylene
PP-R	polypropylene random copolymer
PP-RCT	polypropylene random copolymer with raised pressure resistance
PE-RT	polyethylene with raised temperature resistance

◆ = Only available on request.

APPLICATION AREAS



potable water application



heating system construction



heating and cooling connection



underfloor heating



wall heating



ceiling heating and cooling



industrial floor cooling



industrial floor heating



chilled water technology



agriculture



sports floor heating and cooling



swimming pool technology



chemical transport



rainwater application



irrigation



fire protection sprinkler-systems



shipbuilding



district heating



geothermal



Dear readers,

We are always making decisions – in every minute of every hour of every day. At this moment, you have decided to open our catalogue to consciously find out more about our company aquatherm.

Without knowing the reason behind your decision, we can promise you one thing, namely that the insight into our colourful, yet always slightly green tinged, aquatherm world is sure to impress you!

As a family business which is passionate about all it does we, together with our employees, confidently meet all challenges and, in doing so, are able to trustfully call upon values which have defined our company for already more than four successful decades.

We know where we want to go without forgetting where we came from. Hereby we like to live with the role of not being a “normal” business. The characteristics “being different” and “special” represent our motivation in all that we do to be the best.

We are “state of the pipe” because we act independently and decisively and are hereby always reliable which makes us the leading manufacturer of polypropylene pipes.

We were, are and will remain as this – promise!

But see for yourself and decide upon aquatherm not only in the next few moments but also in the long term.

Best wishes

Christof Rosenberg
Managing Director

Dirk Rosenberg
Managing Director

Maik Rosenberg
Managing Director

Gerhard Rosenberg
President of the Advisory Board

- 1973 aquatherm founded by Gerhard Rosenberg
- 1981 development of the first pipe system made of polypropylene; the colour green becomes a characteristic feature of aquatherm
- 1991 subsidiary Radeberg was founded
- 1996 first certification of the quality management system in accordance with ISO 9001
- 1997 foundation of the sales company in Italy
- 1999 development of fusiotherm® fibre composite pipe
- 2001 aquatherm operates in more than 50 export markets
- 2002 market launch of the aquatherm blue pipe
- 2005 market launch of the aquatherm red pipe and aquatherm black system
- 2010 system expansion of the pipe size to max. ø630 mm
- 2010 Christof, Dirk and Maik Rosenberg assume company management
- 2012 first certification of the environment management system in accordance with ISO 14001
- 2012 market launch of the material fusiotherm® PP-RP
- 2013 first certification of the energy management system in accordance with ISO 50001
- 2015 foundation of the sales company in North America
- 2017 opening of the new pipe extrusion plant
- 2018 opening of the new injection moulding facility
- 2018 foundation of the sales company in England
- 2019 expansion of the industrial prefabrication operation
- 2021 participation in the distribution company aquatherm ibérica s.l.

aquatherm pipe systems

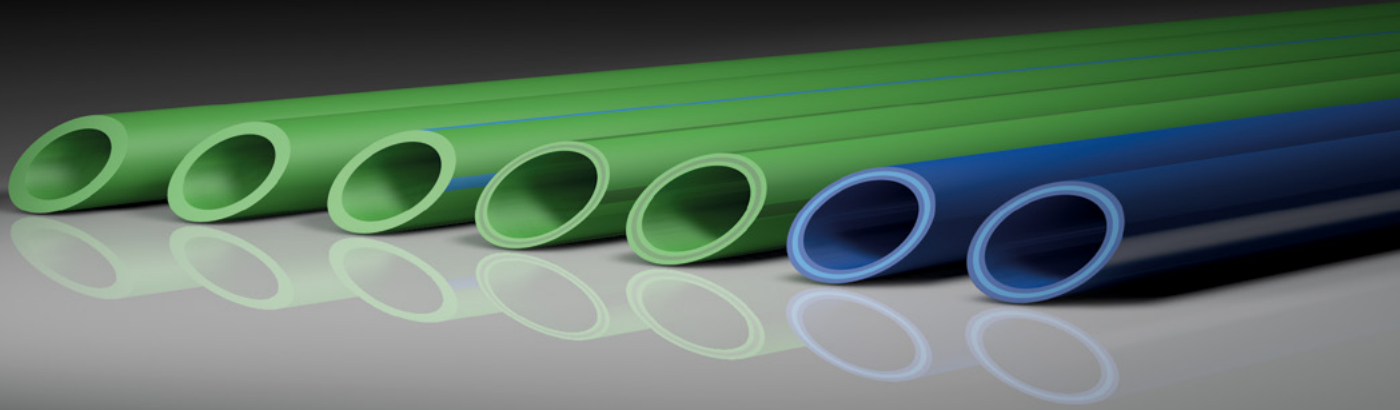

AQUATHERM POLYPROPYLENE PIPE SYSTEMS

The history of the aquatherm pipe systems began in 1973 when Gerhard Rosenberg founded a company for warm water underfloor heating systems. Initially, the owner's garage and basement served as the company's headquarters and production facility. A lot has happened since then.

In the past more than 40 years, aquatherm has proven to be the world's leading manufacturer of plastic pipe systems made of polypropylene for plant engineering and building services. The numerous product lines provide superior solutions in potable water applications, heating systems, fire sprinkler systems, air conditioning and refrigeration technology, as well as in surface heating and cooling systems. The product range comprises almost 17,000 articles in six product lines.

Due to their special material properties, the aquatherm pipe systems convince by their diverse application possibilities.

The aquatherm pipe systems can be used in all areas of new installation, repair and renovation.

AQUATHERM PIPE SYSTEMS

Characteristics

aquatherm polypropylene pipe systems stop corrosion damages. All materials are corrosion-resistant and have reduced flow noise compared to metallic pipes. aquatherm pipes are opaque. There is therefore no risk of algae formation.

Installation

aquatherm pipes and fittings are connected by heat fusion, which creates a homogeneous, cohesive unit with no leak paths. Heat fusion connections are stronger than the pipe itself, providing lasting safety at these critical points of a piping system. A properly executed aquatherm fusion creates a permanent leakproof connection.

An aquatherm pipe with an outside diameter of 20 mm can be heat fused in only 5 seconds.

aquatherm pipe connections can be hydraulic pressure tested or put into operation directly after their fusion. There are no waiting times.

Quality

Quality is very important to aquatherm. This is not only reflected in the national and international certification marks, but also in the high satisfaction level of aquatherm customers, installers and engineers. For more details regarding quality and certificates see page 30.

Warranty

Due to the high product quality, aquatherm offers a 10-years warranty on all pipes and fittings instead of the 2 years applicable under German law. The extended warranty period is covered by a comprehensive insurance policy from a leading insurance company in our industry. For details, see the Warranty section of this catalogue.

Price advantage

aquatherm offers you high quality, durable piping systems at an optimal price / performance ratio.

aquatherm blue pipe

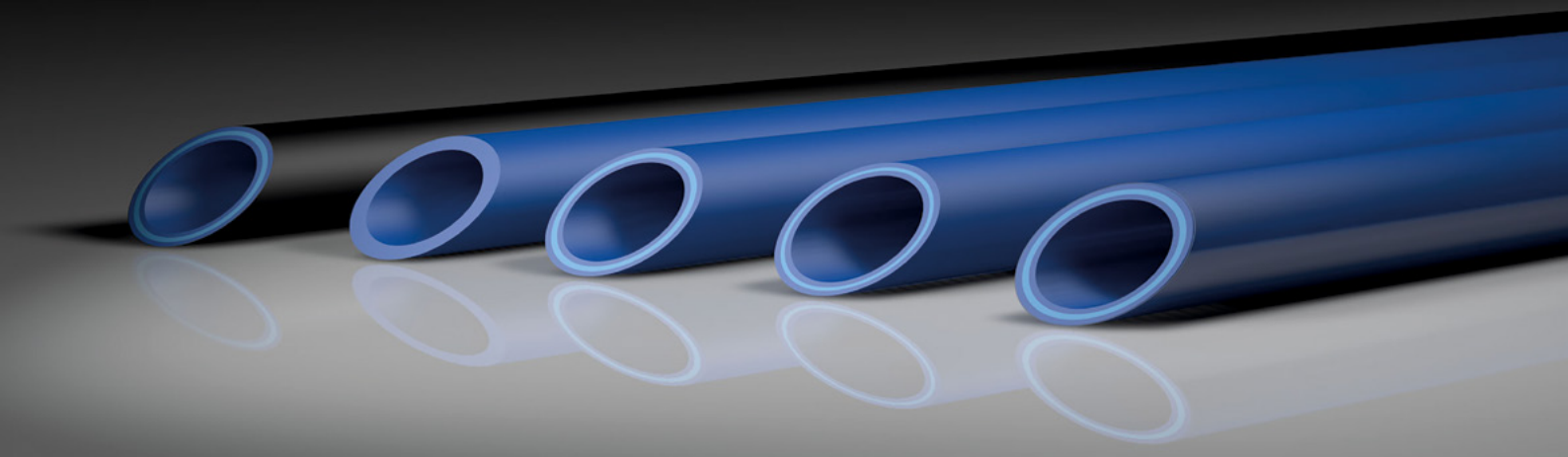

aquatherm blue pipe

Made of corrosion-resistant polypropylene, aquatherm blue pipe is ideal for the transport of cooling and heating media in closed systems. It is particularly well suited for a wide variety of industrial applications. The physical properties of the plastic, such as its high temperature capacity and pressure resistance, are tailored to the specific needs of the heating and cooling sector. aquatherm blue pipe is joined via reliable heat fusion, which produces a virtually leak-free and cohesive unit with excellent safety and durability.

APPLICATION AREAS

- Air conditioning
- Refrigeration
- Chemical transport
- Compressed air
- Building services
- Swimming pool technology
- Shipbuilding
- District heating
- Geothermal
- Irrigation

SYSTEM COMPONENTS

In combination aquatherm the green pipe fittings, the system provides all components required for the piping installation of air conditioning, refrigeration, heating systems and industrial applications. The dimensions range from 20 mm to 630 mm outside diameter.

- Pipes in straight lengths and/or coils
- Fittings
- Flanged joints
- Water point connections and accessories
- Welding devices and machines
- Weld-in and weld-on saddles
- Manifolds
- Shut-off devices
- Cutting and peeling tools
- Installation guide and fastenings
- Transition joints from polypropylene to metal or from metal to polypropylene

aquatherm blue pipe stops corrosion damages!

Steel pipes used in air conditioning systems are particularly susceptible to corrosion on the outside of the pipe. Condensed water that forms between the insulation and the pipe attacks the pipe surface and causes it to corrode.

aquatherm blue pipe is made from 100% corrosion-resistant fusiolen® PP-RCT, which considerably extends the life of the air conditioning system.



corroded steel pipes

Insulation against energy loss

Due to their excellent thermal insulation properties aquatherm blue pipes compared to metal pipes require a considerably thinner insulation.

For detailed information see table on page 81.

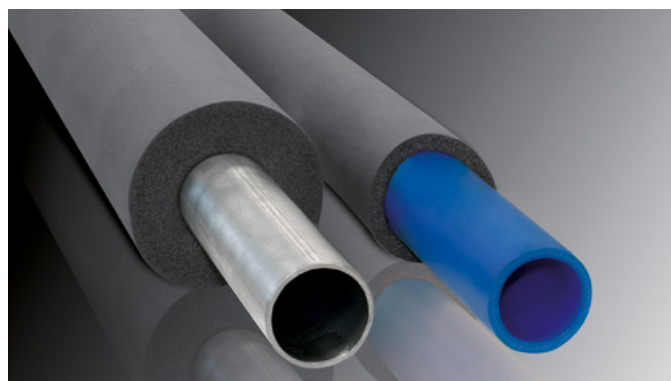

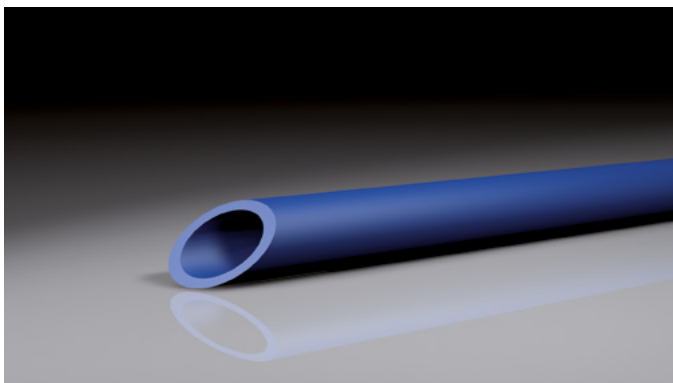

SDR: 11 **ø:** 20–25 mm

Type of pipe: aquatherm blue pipe S

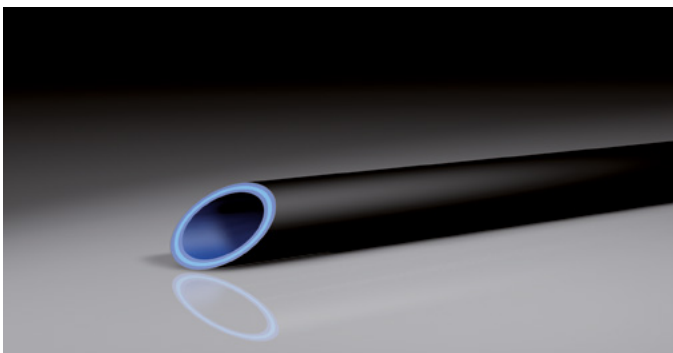

SDR: 7,4 **ø:** 20–25 mm

SDR: 9 **ø:** 32 mm

SDR: 11 **ø:** 40–450 mm

SDR: 17,6 **ø:** 125–630 mm

Type of pipe: aquatherm blue pipe MF (RP) UV

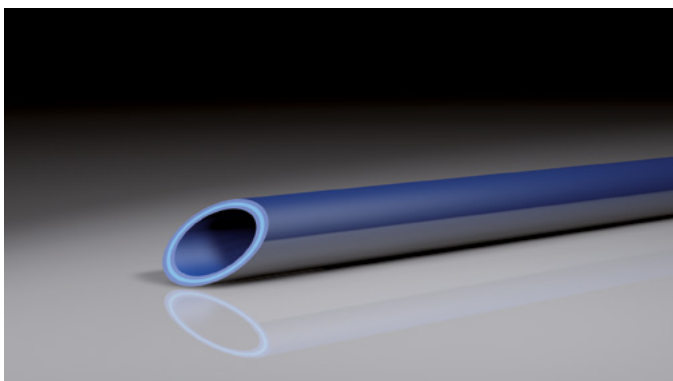

SDR: 7,4 **ø:** 20–25 mm

SDR: 9 **ø:** 32 mm

SDR: 11 **ø:** 40–250 mm

Type of pipe: aquatherm blue pipe MF (RP) OT

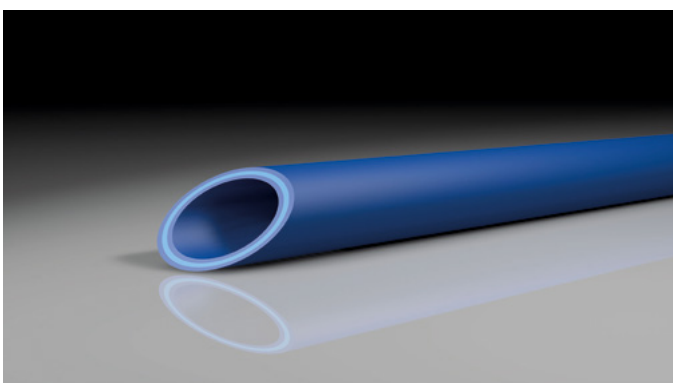

SDR: 7,4 **ø:** 20–25 mm

SDR: 9 **ø:** 32 mm

SDR: 11 **ø:** 32–450 mm

SDR: 17,6 **ø:** 125–630 mm

Type of pipe: aquatherm blue pipe MF (RP)

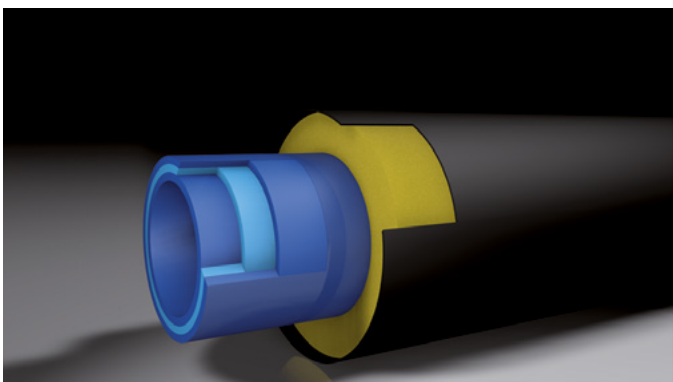

SDR: 9 **ø:** 32 mm

SDR: 11 **ø:** 40–355 mm

SDR: 17,6 **ø:** 125–315 mm

Type of pipe: aquatherm blue pipe MF RP TI

aquatherm blue pipe

COMPARISON OF THE WATER CONTENT PER METER [L]

Ø Dimension mm	aquatherm blue pipe SDR 7,4 MF SDR 7,4 MF OT	aquatherm blue pipe SDR 11 MF RP SDR 11 MF RP OT SDR 11 S	aquatherm blue pipe SDR 17,6 MF RP
Ø 20	0,163	0,206	-
Ø 25	0,254	0,327	-
Ø 32	0,423	0,539	-
Ø 40	-	0,834	-
Ø 50	-	1,307	-
Ø 63	-	2,074	-
Ø 75	-	2,959	-
Ø 90	-	4,252	-
Ø 110	-	6,359	-
Ø 125	-	8,199	9,637
Ø 160	-	13,430	15,792
Ø 200	-	21,010	24,661
Ø 250	-	32,861	38,568
Ø 315	-	52,172	61,223
Ø 355	-	66,325	77,832
Ø 400	-	84,290	98,756
Ø 450	-	106,477	125,036
Ø 500	-	-	154,272
Ø 630	-	-	245,070

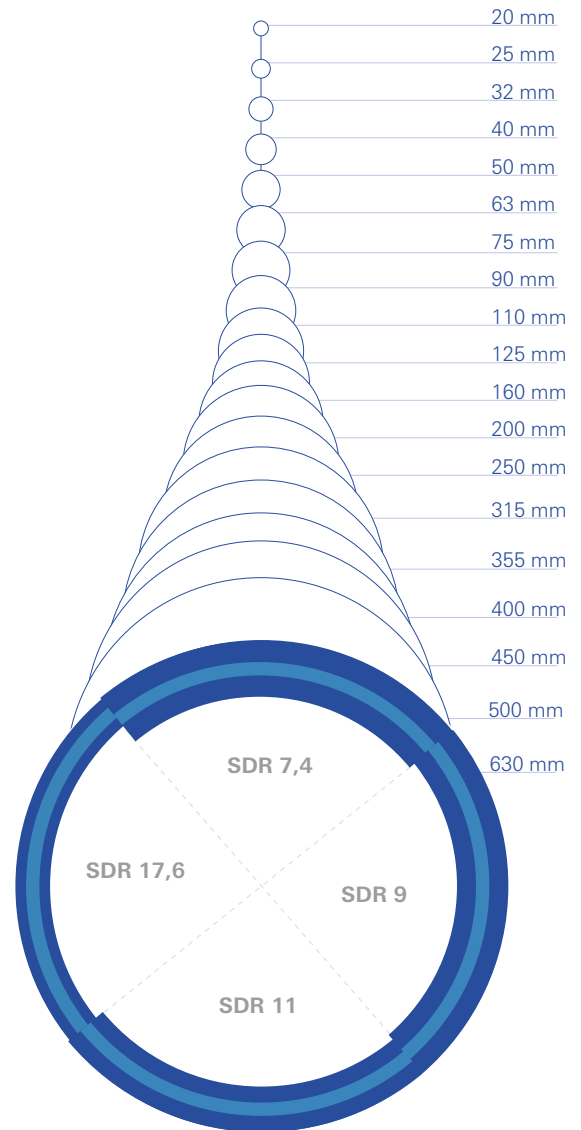

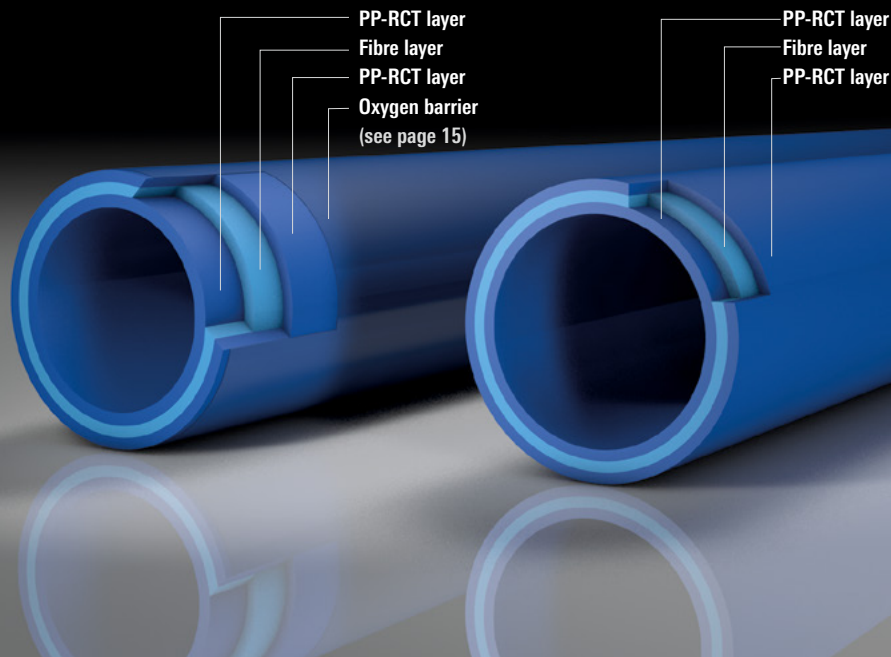

aquatherm blue pipe MF

FIBRE COMPOSITE TECHNOLOGY

aquatherm blue pipe MF is a multi-layer fibre-composite pipe. The pipe is made in a multi-layer extrusion process. The manufacturing process developed by aquatherm enables the integration of glass fibres within the material polypropylene in the middle layer of the pipe. This reinforces the pipe and restricts expansion and contraction.

Advantages of aquatherm blue pipe MF:

- The linear expansion is reduced by at least 75 % compared with standard PP pipes
- The flow rate is increased by 20% at the same pressure conditions due to smaller wall thicknesses.
- High stability
- The coefficient of linear expansion is nearly identical to that of metal pipes, so that compared with common plastic pipes the support intervals can be extended and the number of clamps can be reduced.
- Optimum cost-performance ratio
- Lower weight
- High impact rate
- Simply cut and weld

A diagram for the easy and quick determination of the linear expansion and the expansion compensation can be found on page 72.

aquatherm blue pipe ot SPECIAL TECHNICAL FEATURES

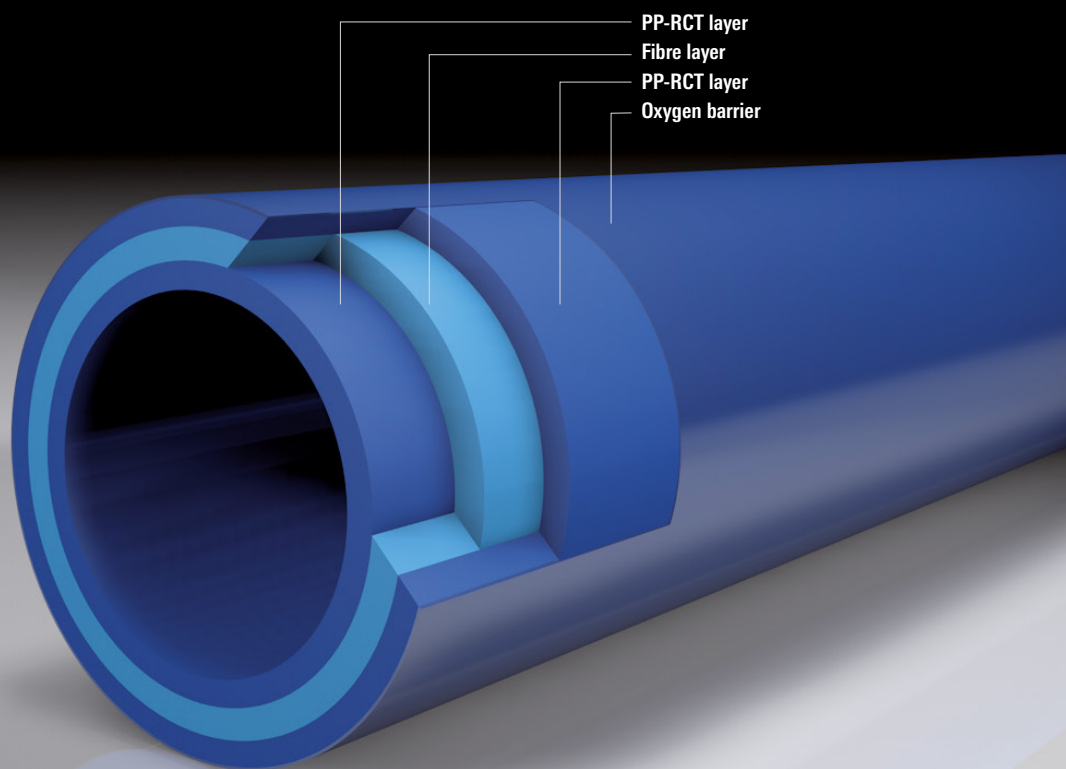

aquatherm blue pipe ot

WITH OXYGEN BARRIER

aquatherm blue pipe ot is a fibre reinforced, oxygen-tight pipe that is equipped with an oxygen barrier and thus meets the requirements of DIN 4726.

In combination with the green pipe fittings, the aquatherm blue pipe OT system provides all components required for the piping installation of air conditioning, refrigeration, heating systems and industrial applications.

Advantages of aquatherm blue pipe OT:

- Oxygen-tight by diffusion barrier
- Certified according to DIN 4726
- Absolutely corrosion resistant
- Less pipe friction
- High stability
- High heat-stability
- High environmental compatibility
- High impact rate
- Resistant against chemicals
- Heat- and sound insulating characteristics
- Very good welding properties
- Considerably thinner insulation

Easy and quick installation technology

aquatherm blue pipe OT also convinces by its easy but effective installation and connection technology. The pipe end and the connecting part are heated up. After joining, the two elements create a permanent bond. aquatherm blue pipe OT has to be peeled with peeling tools (art. no. 50506–50526) before processing.

aquatherm blue pipe ti
SPECIAL TECHNICAL FEATURES

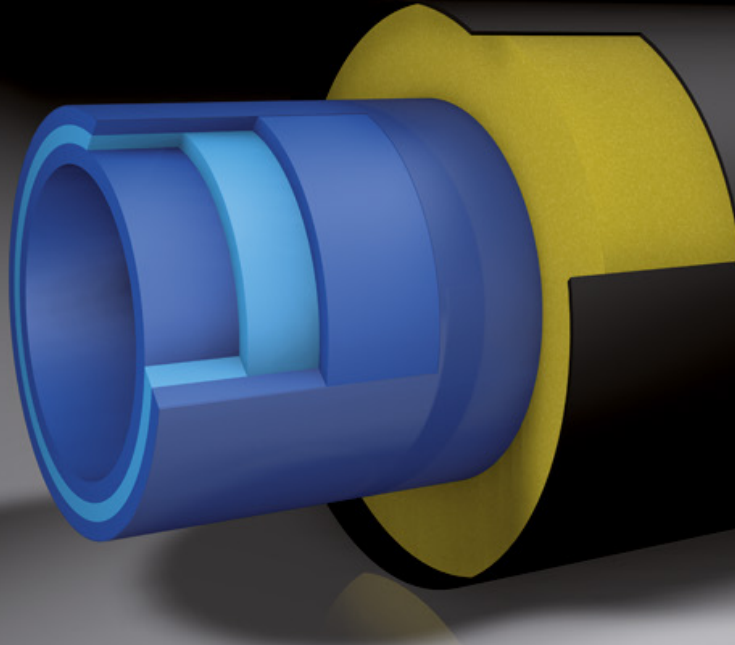

aquatherm blue pipe ti

PRE-INSULATED PIPE SYSTEMS FOR DISTRICT HEATING AND COOLING

For the transport of district heating and cooling energy over long distances a complex, mostly underground pipe system is required. High demands are made on both the medium pipe and the pipe insulation.

With the factory-insulated aquatherm blue pipe ti fiber composite pipes, aquatherm offers the ideal district heating pipes for heating networks that are operated at operating pressures up to 20 bar and operating temperatures up to 90 °C.

The insulated aquatherm blue pipe fiber composite pipes are also used as cooling- and refrigerant agent pipes. The pipe insulation is factory-made with PUR rigid foam that surrounds the medium pipe all over. To protect the insulation layer outward against mechanical or weather-related influences, the outside coating consists of a PEHD-protection pipe.

Fittings such as elbows, bends or tees are insulated at the factory in the same design. The joints between pipe and fitting are manufactured locally at the site in the pipe dimension 32 up to 125 mm by socket welding and in the dimension 160 up to 355 mm by butt-welding process.

The insulation of these joints is done by insulation sockets that enable a continuous insulation of the district heating and cooling pipeline.

aquatherm blue pipe ti pipes are available in length of 5.8 m and 11.6 m. We offer fittings with leg lengths of 0.5 m and 1.0.

The pipe system is optionally also available with trace heating and mains monitoring. Special designs on request.

Medium pipes

aquatherm blue pipe ti

fibre composite pipe system SDR 9 in dimension 32 mm
fibre composite pipe system SDR 11 in dimensions 40 – 355 mm and fibre composite pipe system SDR 17.6 in dimensions 125 – 355 mm for heating, cooling and waste water

aquatherm blue pipe ot ti

oxygen-tight pipe system for heating- and industrial water
fibre composite pipe system SDR 9 in dimension 32 mm
fibre composite pipe system SDR 11 in dimensions 40 – 250 mm

aquatherm ti Application areas	aquatherm blue pipe ti	aquatherm blue pipe ot ti
Heating system construction	●	●
Air conditioning	●	●
Refrigeration	●	●
Swimming pool	●	
Rainwater application	●	
Irrigation	●	
Compressed air systems	●	
Geothermal	●	○
Chemical fluids <small>considering the material resistance</small>	●	●

- System recommended due to its technical advantages
- Application of the system is suitable

aquatherm ti SYSTEM PROPERTIES

aquatherm blue pipe (ot) ti

Low expansion	●
Resistance to corrosion	●
Very good welding properties	●
Less pipe friction	●
High impact resistance	●
Heat-stability	●
Metal deactivation	●
Recyclable	○
Sound- and heat insulation	●
Low weight	●
Self-compensating	●

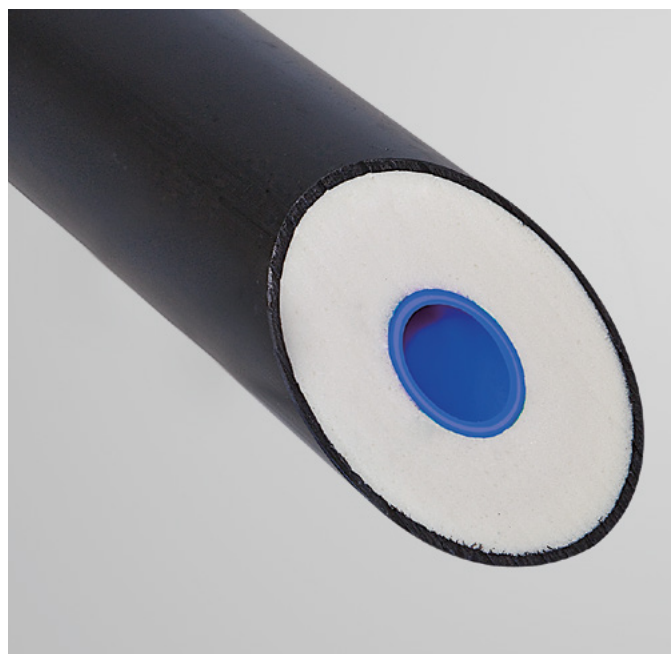

DIMENSIONS

medium pipe	aquatherm blue pipe ti fibre composite pipe SDR 9 (32 mm)/SDR 11	aquatherm blue pipe ot ti fibre composite pipe SDR 9 (32 mm) / SDR 11 (40-250 mm)	aquatherm blue pipe ti fibre composite pipe SDR 17,6	casing pipe
external diameter	dimension	dimension	dimension	external diameter
32 mm	DN 25	DN 25	-	90 mm
40 mm	DN 32	DN 32	-	110 mm
50 mm	DN 40	DN 40	-	110 mm
63 mm	DN 50	DN 50	-	125 mm
75 mm	DN 65	DN 65	-	140 mm
90 mm	DN 80	DN 80	-	160 mm
110 mm	DN 80/100	DN 80/100	-	200 mm
125 mm	DN 100	DN 100	DN 100	225 mm
160 mm	DN 125	DN 125	DN 150	250 mm
200 mm	DN 150	DN 150	DN 200	315 mm
250 mm	DN 200	DN 200	DN 250	400 mm
315 mm	DN 250	-	DN 300	450 mm

* larger dimensions on request

aquatherm ti INSULATION

Material

The aquatherm ti pipe systems are insulated with PUR-rigid foam. This polyurethane foam is made of Polyol and Isocyanate and meets the functional requirements of the EN 253. The foam is homogene with an average cell size of max. 0,5 mm.

For the professional insulation of the pipe and fitting connections, insulation jackets made of PUR-rigid foam are available for the aquatherm ti pipe system, coated with shrink sockets resulting in a permanent connection with the casing pipes.

Material parameters

Technical data	PUR
Cell gas Cyclopentane	> 8 %
Core density	> 60 kg/m ³
Closed cell	> 88 %
Water absorption	< 10 % (Vol)
Compression strength 10 % deformation	> 0.3 N/mm ²
Shearing resistance	> 0.12 N/mm ²
Tangent shearing resistance	> 0.20 N/mm ²
Thermal conductivity at 50 °C	< 0.03 W/mK

aquatherm ti LOSS OF HEAT AND COOLING ENGERGY

Type of pipe	Heat loss at average temperature 40 °C in W/m	Heat loss at average temperature 50 °C in W/m	Heat loss at average temperature 65 °C in W/m
aquatherm blue pipe ot SDR 9 MF RP OT TI			
32 mm	6.86	8.57	11.14
aquatherm blue pipe SDR 11 MF RP TI & MF RP OT TI			
40 mm	6.92	8.65	11.24
50 mm	8.87	11.08	14.41
63 mm	10.10	12.62	16.41
75 mm	10.99	13.74	17.86
90 mm	11.80	14.75	19.17
110 mm	11.27	14.08	13.81
125 mm	11.43	14.29	18.57
160 mm	14.83	18.54	24.10
200 mm	14.60	15.25	23.73
250 mm	14.15	17.69	23.00
315 mm	18.30	22.88	29.74
355 mm	19.34	24.18	31.43

Type of pipe	Cooling energy loss at F: -12 °C R: -6 °C AT: 26 °C in W/m	Cooling energy loss at F: 6 °C R: 12 °C AT: 26 °C in W/m	Cooling energy loss at F: 15 °C R: 18 °C AT: 26 °C in W/m
aquatherm blue pipe SDR 9 MF RP OT TI			
32 mm	5.88	2.86	1.60
aquatherm blue pipe SDR 11 MF RP TI & MF RP OT TI			
40 mm	5.94	2.89	1.61
50 mm	7.65	3.72	2.08
63 mm	8.75	4.25	2.37
75 mm	9.54	4.64	2.59
90 mm	10.26	4.98	2.79
110 mm	9.80	4.76	2.66
125 mm	9.94	4.83	2.70
160 mm	13.03	6.33	3.54
200 mm	12.81	6.22	3.48
250 mm	12.40	6.02	3.37
315 mm	16.23	7.88	4.41
355 mm	16.92	8.22	4.59
aquatherm blue pipe SDR 17,6 MF RP TI			
125 mm	9.94	4.83	2.70
160 mm	13.46	6.54	3.65
200 mm	13.22	6.42	3.59
250 mm	12.79	6.21	3.47
315 mm	16.89	8.21	4.59
355 mm	17.65	8.57	4.79

F = flow, R = return, AT = ambient temperature

aquatherm ti CASING PIPES MATERIAL

The casing pipes of the aquatherm ti pipe system are made of the material PE according to DIN EN 8075. Like insulated steel pipes correspond to the EN 253, aquatherm applies casing pipes, which correspond to the technical requirements of this standard.

The material is characterized by the following mechanical and thermal features.

Material parameters

Technical data	PE 80
Density, g/cm ³ , ISO 1183	0.950
Yield stress, MPa, DIN EN ISO 527	22
Elongation at yield stress, %, DIN EN ISO 527	9
Elongation at break, %, DIN EN ISO 527	300
Tension-E-module, MPa, DIN EN ISO 527	800
Impact strength, kJ/m ² , DIN EN ISO 179	without break
Impact strength, kJ/m ² , DIN EN ISO 179	12
Ball impression hardness, MPa, DIN EN ISO 2039-1	40
Shore hardness, D, ISO 868	63
Medium thermal expansion coeff., K-1, DIN 53752	1.8 · 10 ⁻⁴
Thermal conductivity, W/m · K, DIN 52612	0.38
Electric strength, kV/mm, VDE 0303-21	47
Surface resistance, Ohm, DIN IEC 167	10 ¹⁴
Inflammability, DIN 4102	B2
Physiological harmlessness acc. to BgVV	yes
Chemical resistance acc. to DIN 8075 supplement	complied with
Thermal operating conditions	°C -40 to +80

RING STIFFNESS OF aquatherm blue pipe

All aquatherm polypropylene pipes have a ring stiffness of $\geq 16 \text{ kN/m}^2$ (according to DIN EN ISO 9969) and therefore can be classified in the ring stiffness class SN16.

Underground installation: The depth of the trench adds up from the depth of the frost line, the outer diameter of the pipe and the height of the bedding ($A+D_a+B$). The frost line must be observed: 0.5–9.0 m above the pipe peak (E). If the pipes are installed outside the specified laying depth, a load distribution by steel or concrete slabs must be installed.

Traffic load: SLW 60, heavy forklift (60 tons maximum load).

Trench design: Recommended calculation according to ATV A 127 (basis for calculation).

Laying conditions: We recommend laying the pipes in a narrow trench in which nevertheless sufficient space for working is available.

Bedding layer (B): In normal soil 100 mm sand with round graining size 0–8 mm.
When rock or rocky soils 150 mm sand with round graining size 0–8 mm.
This layer is equally compressed ($\geq 97\%$ Proctor) with gaps in the socket area. Non sustainable soils are made stable by the choice of the bedding layer. Note planning requirements.

Backfilling: The building material 4/8 mm graining is filled in layers in order to construct the lateral bedding (C) and the covering (D).
Thereby the peak of the pipe (E) is covered with minimum 100 mm. Then the main filling (F) with the excavation can be carried out. Note that the grain size does not exceed 300 mm respectively sharp and rough stones are removed. Planning requirements of the filling levels are always to be considered.
Each filling is compressed separately.

Compaction: The compression ($\geq 97\%$ Proctor) of the lateral bedding (C) and the covering (D) is done by hand or with light equipment. If the main filling is made with minimum 20 cm, the trench can be compressed 95 % Proctor upwards from this layer with heavy equipment. The last 50 cm of the trench are compressed with 97–100 % Proctor.

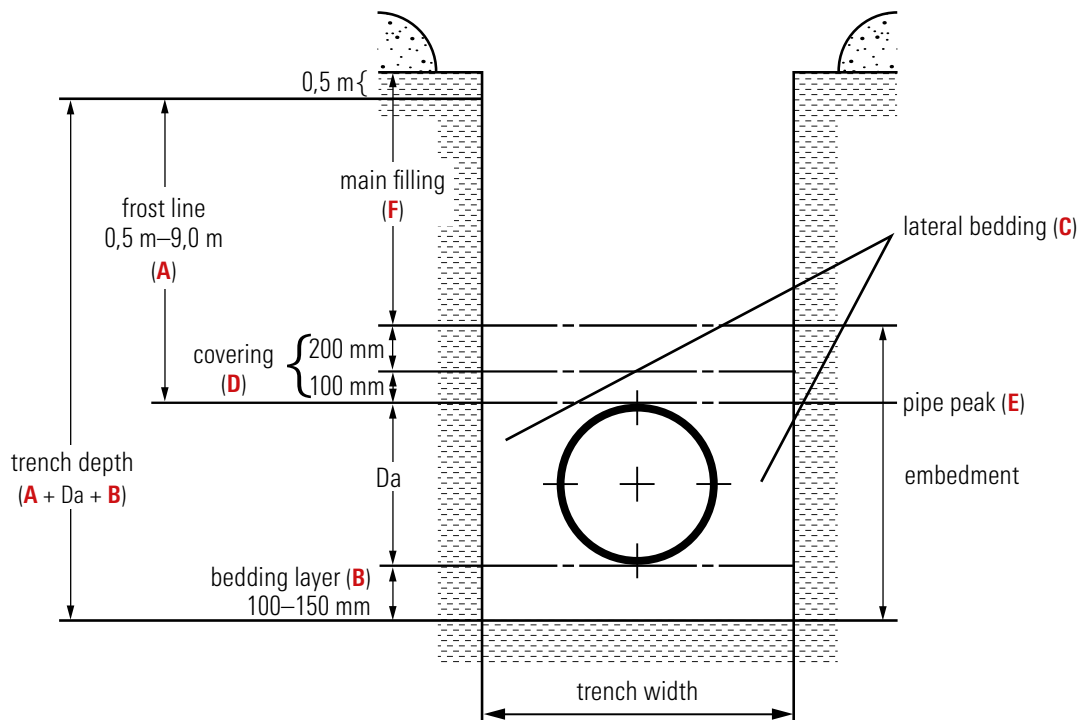

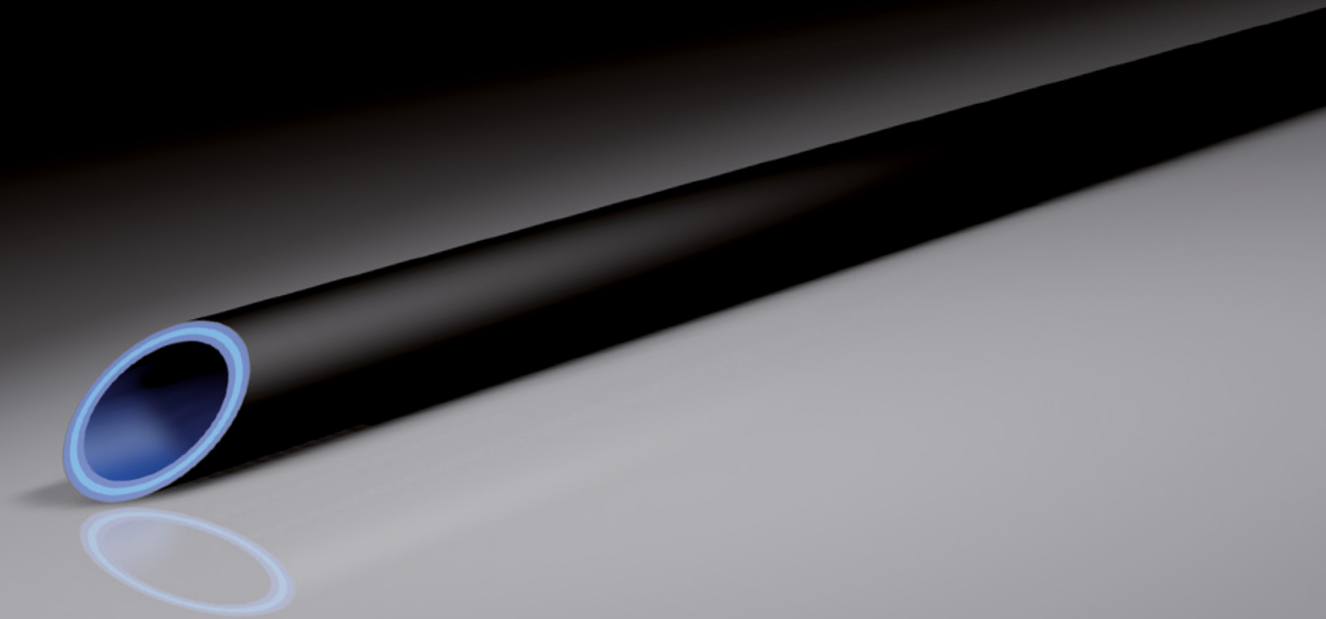

UV-RESISTANCE

Pipes made from fusiolen® polypropylene are normally not exposed to UV-radiation during installation.

To bridge the transport and assembly time, aquatherm polypropylene pipes and fittings are packed in UV-protected packaging. The maximum permissible storage time outdoors is 6 months.

For outdoor pipe laying, aquatherm offers polypropylene composite pipes with a UV protective layer made of polyethylene. The special protection layer prevents damages from sunlight. The pipes are available under the name aquatherm blue pipe MF RP UV.

UV ADHESIVE TAPE

As an alternative to our polypropylene pipes with UV protection layer, wrapping with UV-resistant adhesive tape is possible, if moulded parts or short pipe sections are to be protected.

For this purpose, the adhesive tape recommended by aquatherm (art. no. 10871) should be selected, which shows good resistance to abrasion, moisture, oils, light acids and alkalis as well as weather influences outdoors.

The tape should always be applied to a dry, clean and grease-free surface. The winding should be done with a slight pull and at least 50% overlap.

Further information on page 119.

INTEGRATION OF OTHER SYSTEMS OR COMPONENTS WITH AQUATHERM PIPING FOR PRESSURE PIPE APPLICATIONS

When integrating aquatherm piping systems with other systems or components not made of polypropylene (e.g. valves, pumps, other piping, check valves, strainers, etc), care must be taken to ensure the operating parameters for polypropylene won't damage the other materials or vice versa.

Be aware that even if the aquatherm pipe is compatible with the fluid being transported, other materials in the system may not be. All parts of the system must be verified as compatible with the medium being carried before installing them. And, while aquatherm pipe does not require treatment to protect it from corrosion, metals (ferrous and non-ferrous) in the system may be susceptible to corrosion.

Do not mix aquatherm pipe with other piping systems in conditions that will cause the other system or components to fail.

PERMISSIBLE WORKING PRESSURE

for general pressure pipe applications in permanent operation

Temperature	Years of service	aquatherm blue pipe SDR 17,6 MF RP		aquatherm blue pipe SDR 11 MF RP		aquatherm blue pipe SDR 11 S		aquatherm blue pipe SDR 9 MF RP	
		Permissible working pressure in bar and (psi)							
		bar	(psi)	bar	(psi)	bar	(psi)	bar	(psi)
10 °C 50 °F	10	13,1	(190,0)	25,3	(366,9)	19,3	(279,9)	27,5	(399)
	25	12,9	(187,1)	24,7	(358,2)	18,7	(271,2)	27,1	(393)
	50	12,7	(184,2)	24,1	(349,5)	18,2	(264,0)	26,7	(387)
	100	12,6	(182,7)	23,5	(340,8)	17,8	(258,2)	26,3	(381)
15 °C 59 °F	10	12,3	(178,4)	23,4	(338,7)	17,8	(258,2)	25,7	(373)
	25	12,1	(175,5)	22,8	(330,7)	17,2	(249,5)	25,2	(366)
	50	11,9	(172,6)	22,2	(322,0)	16,8	(243,7)	24,9	(361)
	100	11,7	(169,7)	21,6	(313,3)	16,3	(236,4)	24,5	(355)
20 °C 68 °F	10	11,4	(165,3)	21,4	(310,4)	16,4	(237,9)	23,9	(347)
	25	11,2	(162,4)	21,0	(304,6)	15,9	(230,6)	23,5	(341)
	50	11,0	(159,5)	20,4	(295,9)	15,4	(223,4)	23,1	(335)
	100	10,9	(158,1)	19,9	(288,6)	15,0	(217,6)	22,8	(331)
30 °C 86 °F	10	9,8	(142,1)	18,3	(265,4)	13,9	(201,6)	20,6	(299)
	25	9,6	(139,2)	17,8	(258,2)	13,4	(194,4)	20,2	(293)
	50	9,5	(137,8)	17,3	(250,9)	13,0	(188,5)	19,9	(289)
	100	9,4	(136,3)	16,8	(243,7)	12,7	(184,2)	19,7	(286)
40 °C 104 °F	10	8,4	(121,8)	15,5	(224,8)	11,8	(171,1)	17,7	(257)
	25	8,3	(120,4)	15,0	(217,6)	11,3	(163,9)	17,3	(251)
	50	8,1	(117,5)	14,6	(211,8)	11,0	(159,5)	17,1	(248)
	100	8,0	(116,0)	14,1	(204,5)	10,7	(155,2)	16,8	(244)
50 °C 122 °F	10	7,2	(104,4)	13,0	(188,5)	9,9	(143,6)	15,1	(219)
	25	7,0	(101,5)	12,6	(182,7)	9,5	(137,8)	14,7	(213)
	50	6,9	(100,1)	12,2	(176,9)	9,2	(133,4)	14,5	(210)
	100	6,8	(98,6)	11,9	(172,6)	9,0	(130,5)	14,3	(207)
60 °C 140 °F	10	6,1	(88,5)	10,9	(158,1)	8,3	(120,4)	12,7	(184)
	25	5,9	(85,6)	10,6	(153,7)	8,0	(116,0)	12,4	(180)
	50	5,8	(84,1)	10,3	(149,4)	7,7	(111,7)	12,2	(177)
70 °C 158 °F	10	5,1	(74,0)	8,5	(123,3)	7,0	(101,5)	10,7	(155)
	25	5,0	(72,5)	8,3	(120,4)	6,0	(87,0)	10,4	(151)
	50	4,9	(71,1)	8,1	(117,5)	5,1	(74,0)	10,2	(148)
75 °C 167 °F	10	4,6	(66,7)	7,7	(111,7)	6,0	(87,0)	9,7	(141)
	25	4,5	(65,3)	7,6	(110,2)	4,8	(69,6)	9,5	(138)
	50	4,4	(63,8)	7,3	(105,9)	4,0	(58,0)	9,3	(135)
80 °C 176 °F	5	4,3	(62,4)	7,2	(104,4)	5,7	(82,7)	9,0	(131)
	10	4,2	(60,9)	7,0	(101,5)	4,8	(69,6)	8,9	(129)
	25	4,1	(59,5)	6,8	(98,6)	3,9	(56,6)	8,6	(125)
90 °C 194 °F	5	3,5	(50,8)	5,9	(85,6)	3,7	(53,7)	7,4	(107)
	10	3,4	(49,3)	5,8	(84,1)	3,2	(46,4)	7,3	(106)

SDR = Standard Dimension Ratio (diameter/wall thickness ratio)

S = single-layer

MF = multi-layer fibre

MF RP = multi-layer fibre – raised pressure resistance

For fittings of butt-welded pipe segments a reduction factor of 0.75 (reduction of the table values by 25 %) is effective.

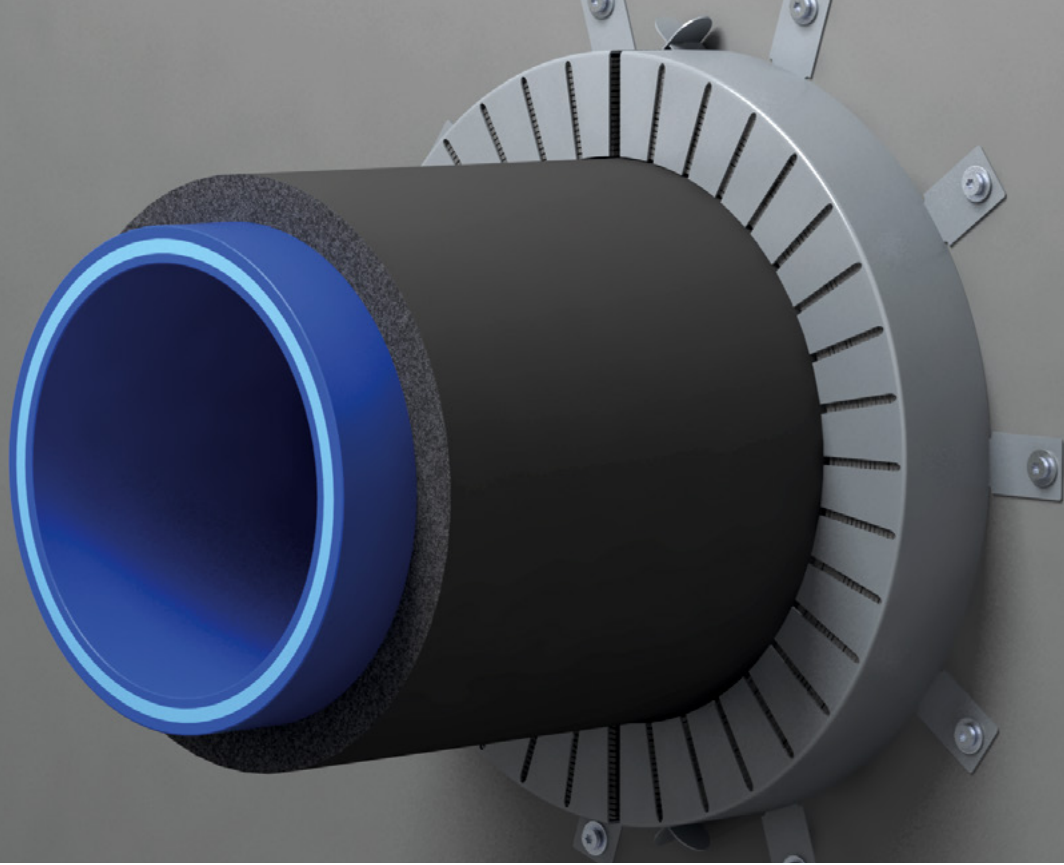

FIRE PROTECTION

The aquatherm polypropylene pipe systems comply with the requirements of the fire classification B2 DIN 4102 (normal inflammable). Compared to natural products like wood, cork or wool, aquatherm PP-R pipes do not produce any gas toxicity. In case of fire, there is no risk of dioxin emissions.

To avoid fire and smoke transmission aquatherm advises the use of fire retardant seals. The fire resistance period is the minimum period in minutes.

The extent of the preventive measures depends on the type of installation. The determination of fire areas and fire classification has to be made in accordance with the law of the country. Information is given by the Planning Department and Building Control Office or the Fire Protection Representative.

Basically, fire walls and ceilings with pipe passages have to be installed to the same fire resistance classification. All fire protection systems with a corresponding classification are suitable for aquatherm polypropylene pipes.

The following companies offer suitable fire protection solutions:

Fire protection pipe shell Conlit 150 U:

DEUTSCHE ROCKWOOL GmbH & Co. KG

Rockwool Straße 37-41
45966 Gladbeck, Germany
Phone: +49 2043 408 0 · Fax: +49 2043 408 444
www.rockwool.de

Fire protection sleeve AWM II:

Flamro Brandschutz Vertriebs GmbH

Am Sportplatz 2
56291 Leiningen
T +49 6746 9410-0
E info@flamro.com
W flamro.de

Hilti Deutschland AG

Hiltistrasse 2
86916 Kaufering, Germany
Phone: +49 800 888 55 22
www.hilti.de

Roku System AWM II in the wall



Roku System AWM II in the ceiling

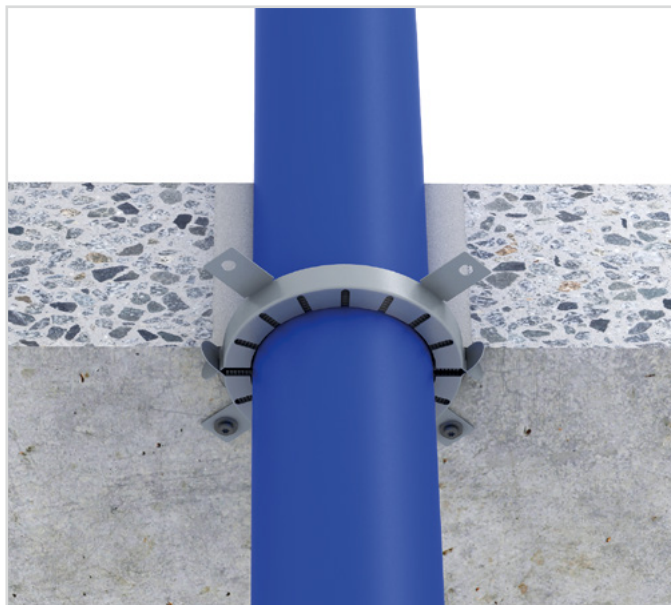

Roku System AWM II with synthesis rubber in the wall



Roku System AWM II with synthesis rubber in the ceiling

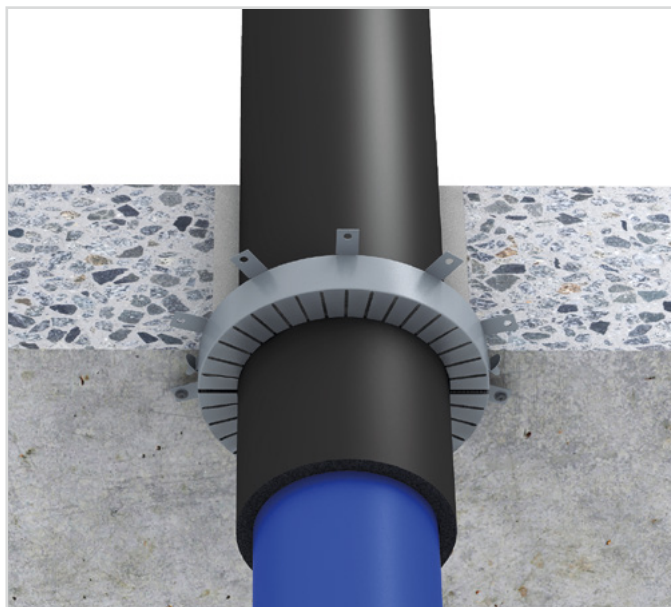

Rockwool Conlit 150 U in the wall

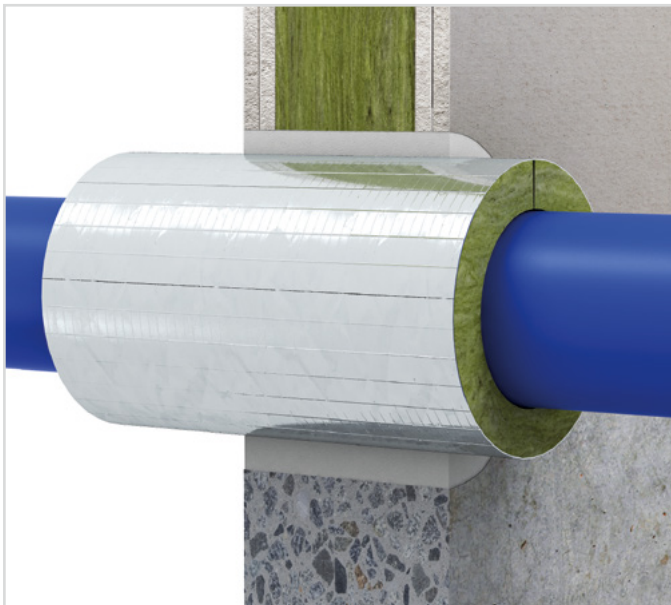

Rockwool Conlit 150 U in the ceiling



EXCERPT FROM THE ROCKWOOL PLANNING AND INSTALLATION AID

R 30- to R 90 pipe penetrations for the aquatherm installation systems with non-combustible media, such as drinking water, heating, cooling

Product name / Material

aquatherm green pipe

PP-R
SDR 6 S,
SDR 7.4 S,
SDR 7.4 MF,
SDR 7.4 MF UV,
SDR 11 S

aquatherm green pipe

PP-RCT
SDR 9 MF RP,
SDR 9 MF RP UV

aquatherm blue pipe

PP-R
SDR 7.4 MF,
SDR 7.4 MF OT,
SDR 7.4 MF UV
SDR 11 S

aquatherm blue pipe

PP-RCT
SDR 9 MF RP,
SDR 9 MF RP OT,
SDR 9 MF RP UV,
SDR 11 MF RP,
SDR 11 MF RP OT,
SDR 11 MF RP UV

aquatherm red pipe

PP-R (B1)
SDR 7.4, MF HI

aquatherm grey pipe

PE-Xc/Al/PE-X
SDR 7.4

aquatherm black system
PP-grid connection pipe

aquatherm orange

system
PE-RT

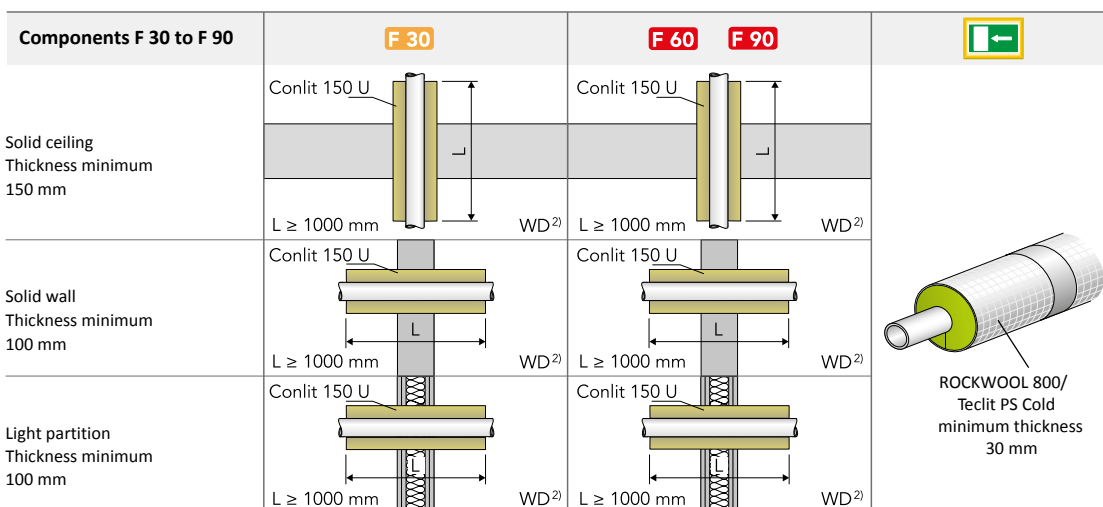

Variant according to ROCKWOOL abP P3726/4140MPA BS.

System	Pipe dimension	Conlit 150 U			ROCKWOOL 800 ^{1), 2), 3)} TECLIT PS Cold ^{1), 2), 3)}			
		Outer diameter Da [mm]	Type ³⁾	Insulation thickness ⁴⁾ s [mm]	Core drilling DK [mm]	EnEV 100 % hot, type	EnEV 50 % hot, type	DIN 1988 cold, type ³⁾
pipes without OT or UV layer	14,0	12/24	24,0	60	15/20	15/20	15/20	
	16,0	16/22	22,0	60	18/20	18/20	18/20	
	17,0	17/21,5	21,5	60	18/20	18/20	18/20	
	20,0	20/20	20,0	60	22/20	22/20	22/20	
	aquatherm green pipe	25,0	25/17,5	17,5	60	28/20	28/20	28/20
	aquatherm blue pipe	26,0	26/17	17,0	60	28/20	28/20	28/20
	aquatherm red pipe	32,0	32/24	24,0	80	35/30	35/20	35/30
	aquatherm grey pipe	40,0	40/20	20,0	80	42/40	42/20	42/40
	aquatherm black system	50,0	50/25	25,0	100	54/40	54/30	54/40
	aquatherm orange system	63,0	63/33,5	33,5	130	64/50	64/30	64/50
pipes with OT or UV layer	75,0	75/52,5	52,5	180	76/70	76/40	76/70	
	90,0	90/65	65,0	220	102/80	102/40	102/80	
	110,0	110/70	70,0	250	114/100	114/50	114/100	
	16,0	18/21	21,0	60	18/20	18/20	18/20	
	20,0	22/19	19,0	60	22/20	22/20	22/20	
	25,0	27/16,5	16,5	60	28/20	28/20	28/20	
	32,0	34/23	23,0	80	35/30	35/20	35/30	
	aquatherm green pipe UV	40,0	42/19	19,0	80	42/40	42/20	42/40
	aquatherm blue pipe OT + UV	50,0	52/24	24,0	100	54/40	54/30	54/40
		63,0	65/57,5	57,5	180	76/50	76/30	76/50
75,0		77/51,5	51,5	180	89/70	89/40	89/70	
90,0		90/65	65,0	220	102/80	102/40	102/80	
110,0		113/53,5	53,5	220	114/100	114/50	114/100	

Notes/special installation conditions

- ¹⁾ In some cases, the available minimum insulation thickness is specified.
- ²⁾ For further insulation, the insulation ROCKWOOL 800 or TECLIT PS Cold can be used.
- ³⁾ For cold pipes, a vapor barrier must be available according to DIN 1988-200, therefore only use fire protection pipe shell Conlit 150U/ Insulating shell ROCKWOOL 800 or TECLIT PS Cold.
- ⁴⁾ Insulation thickness according to EnEV 50% and according to DIN 1988 - 200 suitable for the core bore diameter DK.

All basic conditions of the specified general building inspectorate test certificates must be considered.

FIRE LOAD

The values required for determining the fire load within a fire section are calculated from the total of all flammable materials located within this area.

The calculation for establishing the combustion heat V [kWh/m] for a fire section in the event of an outbreak is dependent on dimensions and materials.

The basis used for the calculation of pipe systems made of polypropylene is the lower calorific value $H_u = 12.2$ kWh/kg (as per DIN V 18230 T1) in conjunction with the mass of material m_{pipe} [kg/m].

The integrated layers of fibres in the aquatherm fibre composite pipes are also considered.

Depending on the calculation procedure, the fire load is worked out with reference to the burn-up factor. This value is designated as m_{factor} and is taken as 0.8 for polypropylene.

Combustion values V [kWh/m] for aquatherm blue pipe

Dimension mm	aquatherm blue pipe SDR 7,4 MF/OT	aquatherm blue pipe SDR 9 MF/OT	aquatherm blue pipe SDR 11 MF/OT	aquatherm blue pipe SDR 17,6 MF
20	1,76	-	-	-
25	2,74	-	-	-
32	-	4,39	3,14	-
40	-	-	4,83	-
50	-	-	7,48	-
63	-	-	11,82	-
75	-	-	16,48	-
90	-	-	23,86	-
110	-	-	35,33	-
125	-	-	45,83	30,03
160	-	-	74,88	48,53
200	-	-	116,64	75,68
250	-	-	181,42	117,64
315	-	-	285,82	186,32
355	-	-	362,93	236,07
400	-	-	460,78	299,73
450	-	-	583,21	378,64
500	-	-	-	468,24
630	-	-	-	740,59

CONNECTION

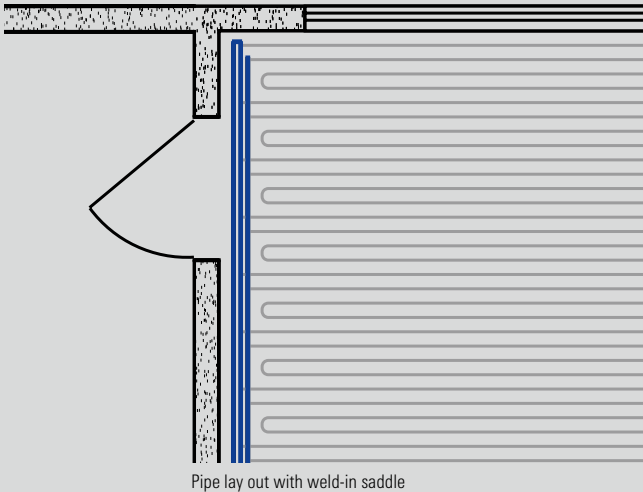

Pipe lay out with weld-in saddle



REVERSE RETURN TECHNIQUE (Tichelmann-principle)

The weld-in saddle technique, developed by aquatherm orange system provides the connection of the heating pipes to a continuous manifold pipe according to reverse return. This technique is applied for the double swing floor design a+b and industrial floor heating.

On applying the reverse return technique all heating circuits have the same length. Thus the pipe lay out ensures the same pressure loss for all heating circuits. A hydraulic balancing of the heating circuits is not required.

Installation

For this connection technique the manifold pipes are made from aquatherm blue pipe or fibre composite pipes and weld-in saddles. The spacing of saddles is determined by the pipe spacing of the heating pipes. aquatherm grey pipe transition adapter are applied for the connection of the oxygen-tight heating pipes. They provide an optimum connection between the aquatherm blue pipe or fibre composite pipes and the aquatherm orange system.

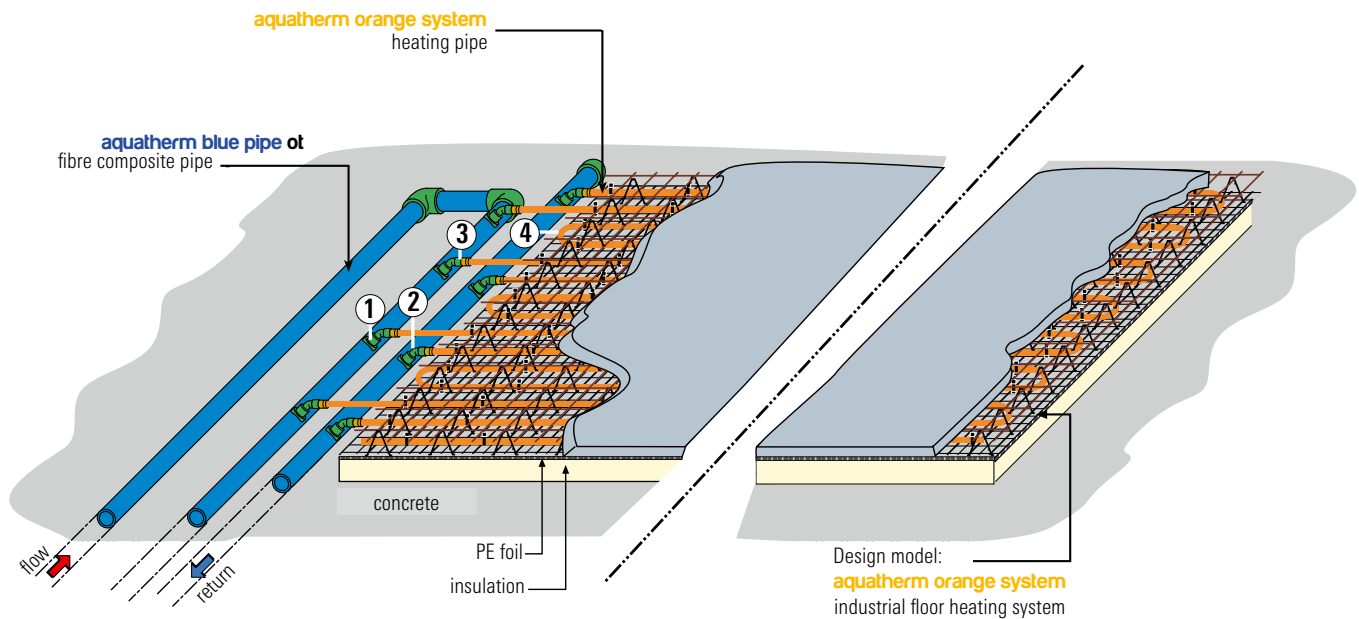

1. aquatherm green pipe weld-in saddle

2. aquatherm green pipe elbow 45°

3. aquatherm grey pipe transition adapter

4. heating pipe

The advantages

of aquatherm pipes and fusiolen® polypropylene

- Corrosion resistant
- Resistant against many chemicals
- High environmental compatibility
- Less pipe roughness
- Heat and soundinsulating characteristics
- Very good welding properties
- High heat-stabilized
- High mechanical stability
- Lighter in weight than steel and copper
- Easy processing
- Well-priced
- Installation aids and fixings

fusiolen®

OUR MATERIAL FUSIOLEN POLYPROPYLENE

Decades of experience in the manufacture and use of PP-R/PP-RCT piping systems and the simultaneous striving for continuous further development have led to numerous improvements in aquatherm system technology.

Newly opened markets place ever increasing demands on the pipe material. Versatile applications require the greatest possible independence of the processed materials. Raw materials with novel properties that could not be achieved until then are required. For this reason, aquatherm has been developing and producing its own innovative polypropylene materials for several years, which meet the global challenges in sanitary and heating technology, in air-conditioning and refrigeration technology, in industrial applications and agriculture, in shipbuilding and in fire protection. Successful results of this research are fusiolen® PP-R, fusiolen® PP-RCT and fusiolen® PP-R FS.

Special heat and extraction stability are only two of the features of this material. Its physical and chemical properties are tailored to the special needs of potable water and heating applications. Above all, the good welding properties and the fusion into a homogeneous unit, resulting in a permanent connection, have made the aquatherm systems and the raw material fusiolen® polypropylene well known worldwide.

Environment

The environmentally friendly material polypropylen fusiolen® PP-R/PP-RCT is recyclable and can be ground, melted and reutilised for various applications e.g. motor-protections, wheel linings, laundry baskets and other kinds of transport boxes. There are no polluting substances with PP-R/PP-RCT either in its processing or in its disposal.

fusiolen® PP-R/PP-RCT – for the benefit of our environment!

Use of metal deactivators

By adding suitable food-approved additives the risk of material damage caused by metal ions under extreme operating conditions is reduced.

Higher long-term heat stabilization

The long-term heat stabilization has been increased to resist to the potential effects of peak temperatures within higher safety parameters.

MATERIAL PROPERTIES

The extrapolated service life of aquatherm PP-RCT pipes is more than 50 years. Peak temperatures of 100 °C arising from short disruptions are unproblematic. Permanent temperatures from 70 °C up to 90 °C reduce the service life of the pipe (see table "Permissible Working Pressure", page 21). When using aquatherm PP-R/PP-RCT pipes, the pressure and temperature conditions according to the table "Permissible working pressure" apply. With regard to pressure and temperature, the operating conditions in the following table are to be used for pipes and pipe connections



TECHNICAL DATA SHEET

Technical properties	fusiolen® PP-R	fusiolen® PP-R/ PP-RCT fibrepipe
Melt-flow index 190 °C/5 kg	0.5 g/10 min	0.5 g/10 min.
Melt-flow index 230 °C/2.16 kg	0.3 g/10 min	0.3 g/10 min.
Modulus of elasticity	800 N/mm ²	1200 N/mm ²
Yield stress	25 N/mm ²	30 N/mm ²
Density	0.9 g/cm ³	1.0 g/cm ³
Tensile strength	25 MPa	35 MPa
Inflammation temperature	430 °C–450 °C	490 °C–500 °C
Thermal expansion coefficient	1.5 *10 ⁻⁴ K ⁻¹	0.35 *10 ⁻⁴ K ⁻¹
Coefficient of thermal conduction	0,15 W/mK (measured at pipe)	0,15 W/mK (measured at pipe)
Coefficient of friction in pipes	0.007	0.007
Bending radius	6 x d	
Water absorption	< 0.02 %	< 0.02 %
Electrical properties	fusiolen® PP-R	fusiolen® PP-R/ PP-RCT fibrepipe
Relative permittivity	2,3 (in case of 1 MHz)	2,3 (in case of 1 MHz)
Puncture voltage	500 kV/cm	500 kV/cm
Specific resistance	> 10 ¹⁷ Ω cm	> 10 ¹⁷ Ω cm
Surface resistance	10 ¹⁴ Ω	10 ¹⁴ Ω
Dissipation coefficient	0.0002 (in case of 50 Hertz)	0.0002 (in case of 50 Hertz)

AQUATHERM & ECOLOGY

Environmental protection is very important to aquatherm.

The aquatherm pipe systems and fittings are not only characterized by their long service life, but also by their excellent environmental compatibility. Since its foundation, aquatherm has been attaching great importance to the fact that its products and manufacturing processes do not pollute our sensitive ecosystems. Through the development of recyclable materials, it is possible that these can easily be fed into new productions.

Long before environmental protection was regarded as a global issue, the aquatherm green pipe system met the ecological standards that are required today. For more than 45 years, the aquatherm philosophy has emphasized that ecological and economical interests in production, distribution and application of a product are not contradictory.

The environmentally friendly raw material fusiolen® is used for the production of the aquatherm pipe systems. To ensure its environmental compatibility the basic material polypropylene, as well as all contained additives (colour pigments and stabilizers) were extensively tested, not only by aquatherm's own laboratory, but also by independent laboratories.

Their results show that the polypropylene granules fusiolen® and the pipe systems from which it is manufactured, comply with the highest ecological standards.

ENVIRONMENTAL PRODUCT DECLARATION AND LEED CERTIFICATION

As the world’s first pipe system manufacturer, aquatherm has developed an Environmental Product Declaration (EPD) for its products. Thus the aquatherm products contribute to the attainment of points in the LEED system. Learn more about the importance of life cycle assessments, environmental product declarations and LEED for planners, engineers and builders.

Life-Cycle Assessments (LCAs)

LCAs provide a comprehensive evaluation of the upstream and downstream energy and environmental impacts associated with a product. They are comprised of five parts: Goal, Scope, Life-Cycle Inventory Analysis, Results, and Interpretation. aquatherm has chosen the cradle-to-gate approach for its LCA „Life Cycle of Polypropylene Pressure Piping Systems“ encompassing the product life cycle from the extraction of raw materials through manufacturing and product distribution.

Environmental Product Declarations (EPDs)

The EPD is the document used to convey the LCA’s results to the products’ users and specifiers. It focuses on information about a product’s environmental impact such as global warming, ozone depletion, water pollution, ozone creation, and greenhouse gas emissions.

EPDs typically are verified following the processes described in ISO 14025, EN 15804, and ISO 21930 for construction products. These steps include: 1) Finding or developing a Product Category Rule (PCR); 2) Generating the input data and performing an LCA according to a specific PCR; 3) Compiling information in the EPD; 4) Verification of the EPD and LCA; and 5) Registration and publication.

aquatherm utilized ThinkStep as independent third party to conduct an ISO-conformant LCA for its following product lines: aquatherm had an ISO-compliant life cycle assessment carried out by ThinkStep as an independent third party for the following product lines: aquatherm green pipe, aquatherm blue pipe, aquatherm red pipe, aquatherm lilac pipe (no longer available) and the aquatherm black system for surface heating and cooling. In the study, one meter (3.2 ft) length of pipe was selected as functional unit per the requirements of the respective PCR “Piping Systems for Use for Sewage and Storm Water (Under Gravity)”. The declared product was defined as a representative average of the five aquatherm product offerings.

Two different test methodologies were chosen to analyze the products in the LCA: Tool for Reduction and Assessment of Chemical and Other Environmental Impacts (TRACI) 2.1 and CML 2001, a method developed by the Institute of Environmental Sciences at the University of Leiden in the Netherlands. The TRACI 2.1 method utilized impact categories, including Global Warming Potential (GWP), Acidification Potential (AP), Eutrophication Potential (EP), Ozone Depletion Potential (ODP), and Smog Formation Potential (SFP). The results of the findings are summarized in the following table.

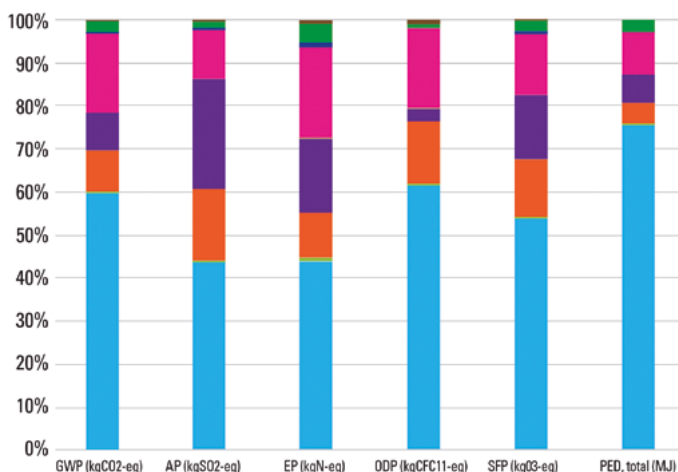

Environmental impacts and Primary Energy Demand of aquatherm PP-R piping systems according to TRACI 2.1

Upon completion of the aquatherm product-specific LCA, aquatherm submitted its products, the LCA, and supporting documentation for independent verification by NSF International. The verification process included a review by an independent panel of experts, an audit of the manufacturing facilities and records, and a confirmation of material formulations. aquatherm’s Product-Specific Type III third-party verified EPD was published Dec. 18, 2015: <http://info.nsf.org/Certified/Sustain/ProdCert/EPD10069.pdf> Within the EPD, you will find information on aquatherm, its product descriptions, data quality requirements, raw-materials origins, a manufacturing diagram, a declaration of parameters per the PCR, and the lifecycle-impact conclusion for aquatherm pipe.

Advantages of PP-R piping systems and radiant panels compared to metal systems

The analysis has shown that polypropylene comprises nearly 50% or more of the impact contribution depending on the impact category. Also Primary Energy Demand (PED) is mainly driven by polypropylene. However, this is because of the embodied energy content of the resin rather than fuel consumption upstream. In other words, aquatherm polypropylene has available energy within the material that can be recovered later in the product’s life cycle during recycling. This differs greatly compared with metals. With metal systems, all of the energy is used in the original processing of the raw material. Metals do not provide energy to the recycling process.

Thus aquatherm PP-R piping systems and radiant panels can provide a more sustainable, lower environmental impact option to designers, engineers, and building owners when compared with other piping and radiant panel systems.

How is aquatherm’s EPD relevant to LEED v4 points?

LEED stands for „Leadership in Energy and Environmental Design“ and is one of the most popular green building certification programs used worldwide. It was developed by the U.S. Green Building Council (USGBC) in 1998 and has defined various standards for environmentally friendly, resource-saving and sustainable construction.

LEED v4 incorporates point structures to encourage the use of products/ materials that environmentally, economically, and socially support preferable life-cycle impacts. Point structures were developed to reward the selection of products from manufacturers who have verified improved environmental life-cycle impacts.

aquatherm’s green pipe, blue pipe, red pipe and black system products have attained Type III EPD status through independent verification by NSF International. They now can be utilized as a portion of the 20 permanent products engineers must have throughout their LEED-certified buildings. aquatherm’s EPD also carries double the weight of the Industry-Wide (Generic) EPD in terms of LEED product value and four times the weight of a self-certified Product-Specific Declaration by a manufacturer. aquatherm has continued its industry leadership position by becoming the first piping manufacturer to have an independently verified, Product-Specific Type III EPD and by supporting building owner to achieve LEED certification.

For further information please see our White Paper: <https://www.aquatherm.de/company/sustainability/?lang=en>

- 1. PP-R
- 2. Other Plastics
- 3. Brass Fittings
- 4. Additives
- 5. Auxiliary Materials
- 6. Energy
- 7. Inbound Transport
- 8. Packaging
- 9. Waste Treatment



COMPLIANCE WITH THE SYSTEM STANDARD

Various national and international independent authorities and institutions confirm aquatherm’s quality standard. You can see our certificates on our website at www.aquatherm.de/products/certificates

AQUATHERM QUALITY MANAGEMENT SYSTEM

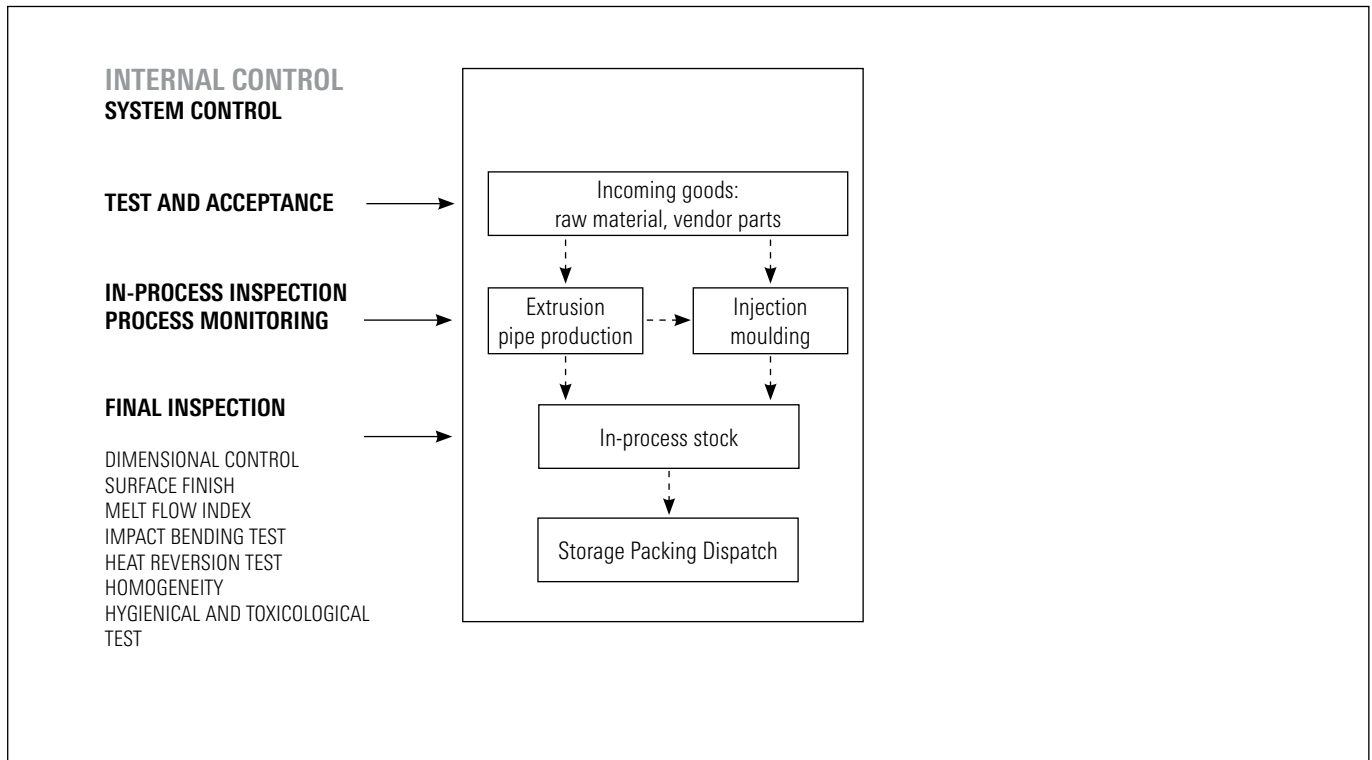

In addition to the permanent internal quality control, an external control is conducted by f.e. SKZ, SAI, TGM, Hygieneinstitut.



SYSTEM CONTROL

The production of a quality controlled pipe system demands the supervision, regulation and control of all work operations. All results and processes have to be documented.

This requires

- test and acceptance of incoming goods**
- process control**
- in-process inspection and test**
- final inspection and test**

The minimum requirements for self-monitoring are derived from the monitoring regulations of the South German Plastic Center (SKZ), DIN guidelines and DVGW-worksheets, compliance with which is checked by neutral test institutes as part of external monitoring.

Conformance to the standards is verified by independent institutes in form of internal audits and laboratory tests.

aquatherm has many years of experience in extrusion and injection moulding and is the market leader and pioneer in the manufacture of polypropylene pipe systems.

This experience is reflected in internal quality standards and laid down procedures, which are taken strongest note of and are documented by the constant quality of our products.

INTERNAL CONTROL

Trained and qualified employees and a modern equipped laboratory ensure that all tests and monitorings requested are carried out in accordance with the quality control policy, which includes

- control of inspection, measuring and test equipment process and production control**
- receiving inspection test**
- in-process inspection**
- final inspection**

All internal quality controls are documented and recorded in accordance with the quality control policy.

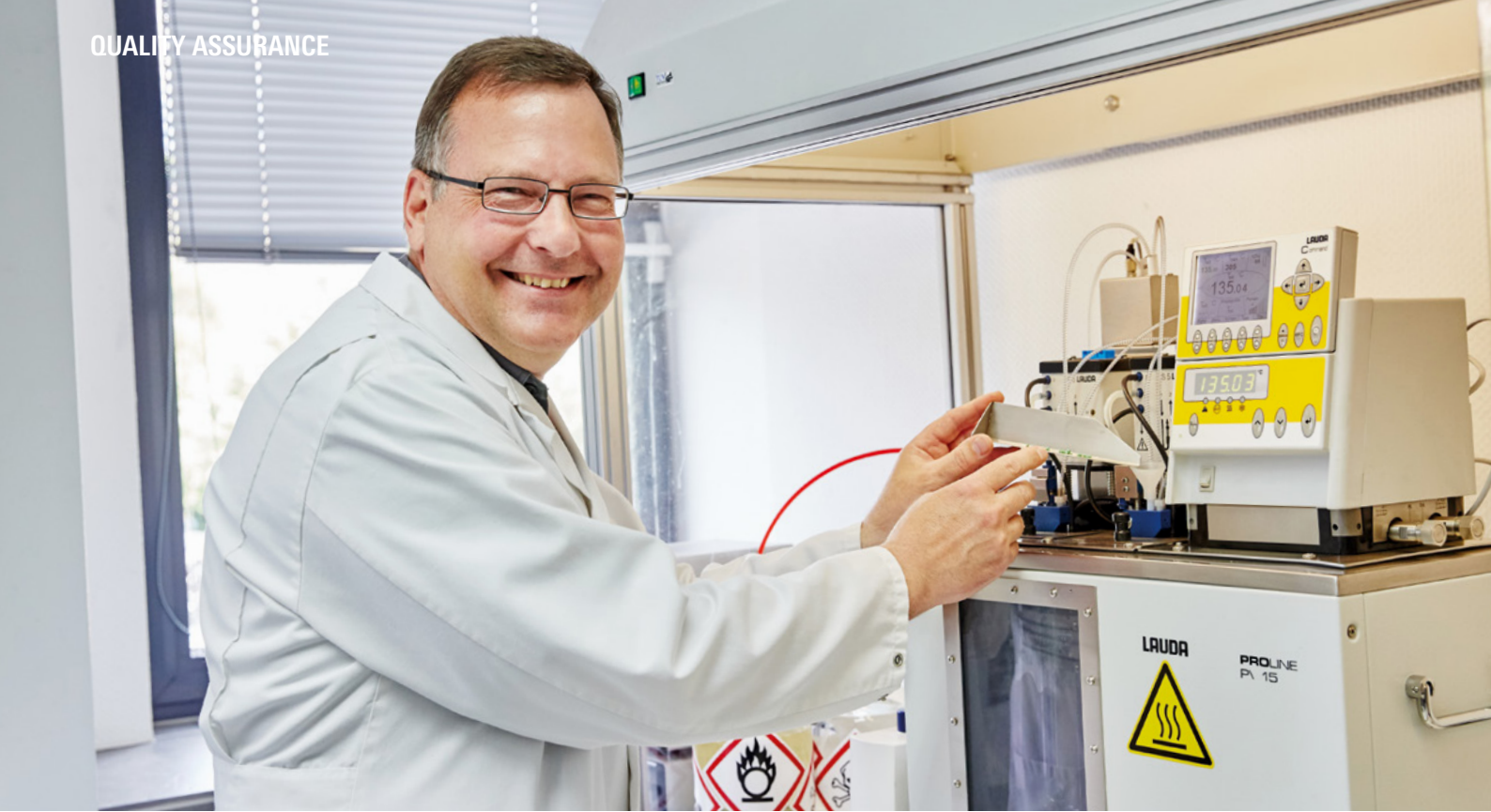

QUALITY ASSURANCE

Test and acceptance of incoming goods

All incoming goods are subject to a test. This ensures that incoming products conform to specified requirements. Goods which have not been tested are not released for production.

In-process inspection and test

The quality plan requires that tests and inspections are carried out before and during production. At the start of production all quality relevant data are checked by the quality assurance department. Preproduction samples are tested by the laboratory technicians for

- Surface finish
- Dimensional accuracy of the test samples
- Data from extrusion and injection moulding machines

and whether they meet the specifications. Only if this is ensured, it will be released for production. The tests are carried out at the beginning of each series production in order to guarantee impeccable quality.

Process control

Ultrasonic measurement and process data recording in the field of extrusion are only two examples of the extensive quality control process.

This equipment enables constant observation and control of production.

Ultrasonics automatically measure and report any deviations in tolerance to the cutting device on the extrusion machine so that the sizing plant automatically isolates a substandard product. This ensures that only perfect quality products are packed and stored.

All data received during production is analyzed in detail.

Final inspection and test

After completion of the products, all final inspections specified in the test plan are conducted. Only if it has been proven that all the required tests are fully documented and the results correspond to the optimum system quality, the products are sent to the finished goods warehouse.

The final inspection and test covers the following test procedures:

- Dimensional control
- Surface finish
- Measurement of the melt flow index
- Impact bending test
- Heat reversion test
- Homogeneity of the material
- Internal pressure test

In addition to the tests mentioned above, daily hygiene tests in accordance with KTW/DVGW guidelines are carried out regularly in the company's own sensory analysis laboratory.



DVGW type examination certificate
DVGW-Baumusterprüfzertifikat

Field of Application
Anwendungsbereich: products of water supply
Produkte der Wasserversorgung

Owner of Certificate
Zertifizierer: aquatherm GmbH
Biggen 5, D-57439 Attendorn

Distributor
Vertreiber: aquatherm GmbH
Biggen 5, D-57439 Attendorn

Product Category
Produktart: installation systems with special pipes: drinking water (8801)



Product Description
Produktbezeichnung: drinking water system consisting of plastic pipes (P) plastic fittings (PP-R), type S-KK

Model
Modell: aquatherm green pipe SDR8 S (fusiotherm)

Test Reports
Prüfberichte: laboratory control test: 27516/2, 1/123612 from 02.0 laboratory control test: 27616/2, 1/123613 from 06.0 KTW testing: K-271607-16-Ba/et from 13.06.2016 (hygienic testing: W-274850-15-Si/Ni from 25.08.201 KTW testing: K-231614-13-Ba/et from 02.07.2013 (hygienic testing: W-274849-16-Si/Ni from 25.08.201 laboratory control test: 27606/2, 2/74867 u. Erg. fro

Test Basis
Prüfgrundlagen: DVGW W 534 (01.05.2004)
DVGW W 544 (01.05.2007)
UBA KTW (07.10.2008)
DVGW W 279 (01.11.2007)

Date of Expiry / File No.
Abkündigung / Aktenzeichen: 14.02.2022 / 17-0188-WNV

28.04.2017 Qi A-1/2
Date issued by: SkZ, Head of Certification Body
Datum, Beibehaltung, Wsk. Erhalt der Zertifizierung
DVGW CERT GmbH ist ein anerkanntes Stelle für Zertifikate gemäß der DIN EN ISO/IEC 17065:2013 für die Zertifizierung von Produkten der Energie- und Wasserversorgung



DVGW type examination certificate
DVGW-Baumusterprüfzertifikat

Field of Application
Anwendungsbereich: products of water supply
Produkte der Wasserversorgung

Owner of Certificate
Zertifizierer: aquatherm GmbH
Biggen 5, D-57439 Attendorn

Distributor
Vertreiber: aquatherm GmbH
Biggen 5, D-57439 Attendorn

Product Category
Produktart: installation systems with special pipes: drinking water installation systems (8801)

Product Description
Produktbezeichnung: drinking water system consisting of plastic pipes (PP-R) and welding fittings (PP-R), type S-SK

Model
Modell: aquatherm green pipe SDR8 S (fusiotherm)

Test Reports
Prüfberichte: mechanical test: 146613/2, 1/109124 from 27.02.2014 (SKZ) mechanical test: 146713/2, 1/109125 from 27.02.2014 (SKZ) mechanical test: 146696/2, 1/84491 from 08.02.2009 (SKZ) mechanical test: 146706/2, 1/84492-84493 from 23.01.2009 (SKZ) KTW testing: K-231615-13-Ba/et from 02.07.2013 (WHY) KTW testing: K-230655-13-Ba/et from 06.05.2013 (WHY) hygienic testing: W-206324-11-Si from 03.08.2011 (WHY)

Test Basis
Prüfgrundlagen: DVGW W 534 (01.05.2004)
DVGW W 544 (01.05.2007)
BGA KTW (12.12.1985)
DVGW W 279 (01.11.2007)

Date of Expiry / File No.
Abkündigung / Aktenzeichen: 25.09.2019 / 16-0435-WNV





06.06.2016 Qi A-1/2
Date issued by: SkZ, Head of Certification Body
Datum, Beibehaltung, Wsk. Erhalt der Zertifizierung
DVGW CERT GmbH ist ein anerkanntes Stelle für Zertifikate gemäß der DIN EN ISO/IEC 17065:2013 für die Zertifizierung von Produkten der Energie- und Wasserversorgung

ZERTIFIKAT

SKZ

SKZ - Testing GmbH awards the following company
aquatherm GmbH
Biggen 5
57439 Attendorn
Germany

Production site: aquatherm GmbH, 01454 Radeberg
The right to use the SKZ testing and inspection mark



A 632
for the following plastic products
Fibre multilayer pipes made of PP-R SDR 9, group 1 and 2
Trade name: aquatherm green pipe SDR9 MF-RP
SKZ specification for tests and inspection **HR 3.28:**
Users of the SKZ mark are obliged to observe the required testing of these products.
Date of initial certification: 1 October 2013
Date of expiry: 4 October 2023
Würzburg, 30 August 2019!



The original language of this certificate is German. In case of doubt, the German version is obligatory.
SKZ - Testing GmbH, Friedrich-Bergius-Ring 22, 97076 Würzburg, Germany, Tel. +49 931 4164-0, testing@skz.de, www.skz.de

ZERTIFIKAT

SKZ

SKZ - Testing GmbH awards the following company
aquatherm GmbH
Biggen 5
57439 Attendorn
Germany

Production site: aquatherm GmbH, 57439 Attendorn
The right to use the SKZ testing and inspection mark



A 644
for the following plastic products
Fibre multilayer pipes made of PP-RCT/PP-RCT GF/PP-RCT SDR 9, group 1 and 2
Trade name: aquatherm green pipe SDR9 MF-RP
SKZ specification for tests and inspection **HR 3.28:2016-03**
Users of the SKZ mark are obliged to observe the required regulations for the production and testing of these products.
Date of initial certification: 1 October 2013
Date of expiry: 4 October 2023
Würzburg, 30 August 2019!



The original language of this certificate is German. In case of doubt, the German version is obligatory.
SKZ - Testing GmbH, Friedrich-Bergius-Ring 22, 97076 Würzburg, Germany, Tel. +49 931 4164-0, testing@skz.de, www.skz.de

EXTERNAL CONTROL

External supervision consists of tests of a defined scope and in defined intervals. The respective supervising institutions appoint authorized test organizations to carry out these tests.

The external supervision includes external tests of the products and

- a) internal audit of aquatherm's quality assurance system and test procedures,
- b) calibration of the test equipment and
- c) hygienic and toxicity tests.

The results of the supervisory visits as well as external tests made on pipe and fitting samples are confirmed to aquatherm in test certificates.

In Germany, the external supervision of the aquatherm pipe system is carried out by the

- SKZ (Süddeutsches Kunststoffzentrum in Würzburg)
- Institute for Hygiene, Gelsenkirchen (Hygieneinstitut in Gelsenkirchen)

who are authorized by the DVGW (German Institute for Gas and Water) as controlling organization. The external supervision for certificates from abroad is carried out in a similar way.

Storage/packing/dispatch

Upon successful release the products are stored in suitable warehouses.

Internal instructions control the method of packing, storage and dispatch of the products. The warehouse staff are responsible for controlling the stored product.



HEATING AND AIR-CONDITIONING

aquatherm blue pipe includes all pipe installation components for chilled water, hot water and various industrial applications. The reduced wall thickness offers higher flow rates and the products feature high heat-stabilized properties.

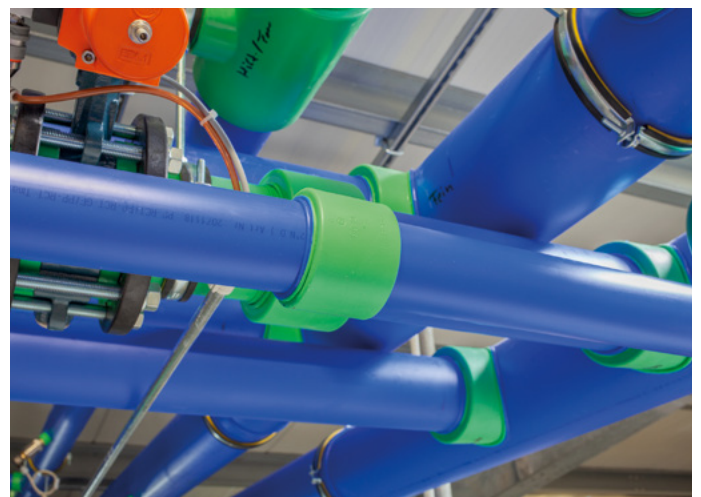
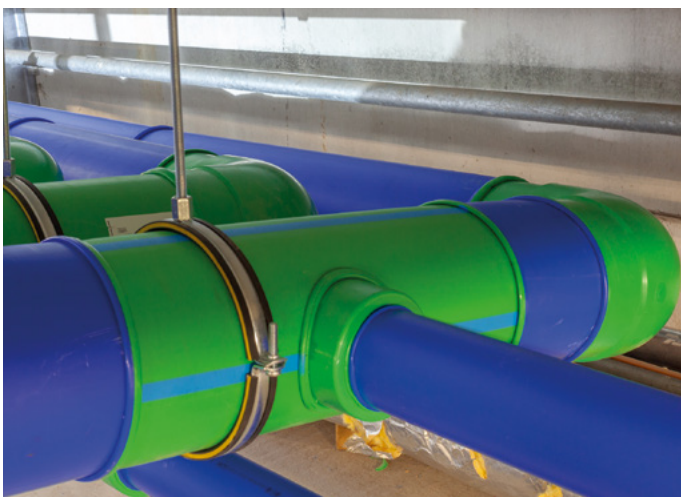

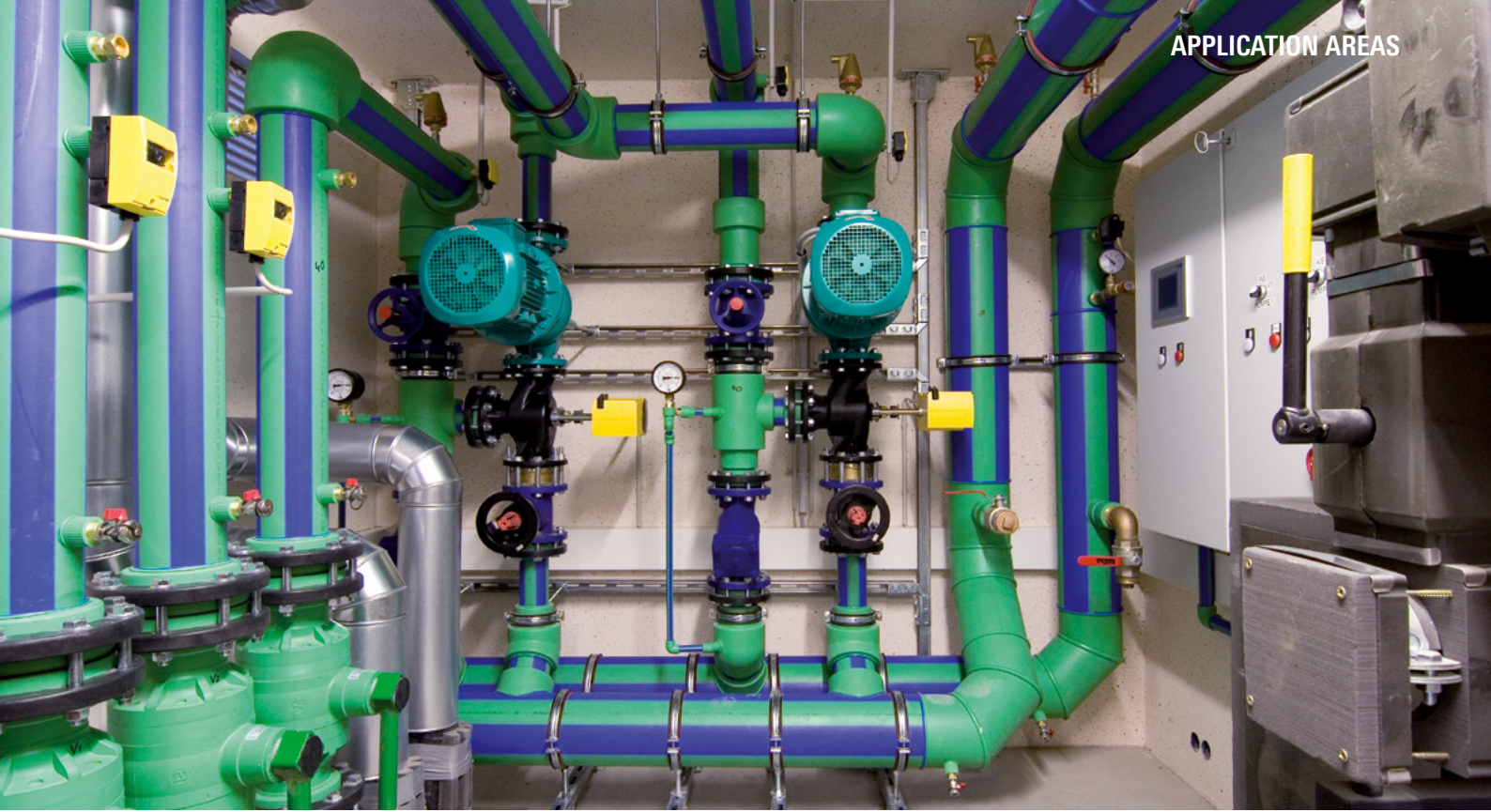

BUILDING SERVICES

Flange connections and transition joints enable the connection of all components to the central heating system and on the floor.



Risers and distribution piping for heating supply should be planned and installed with aquatherm blue pipe fibre composite pipes.

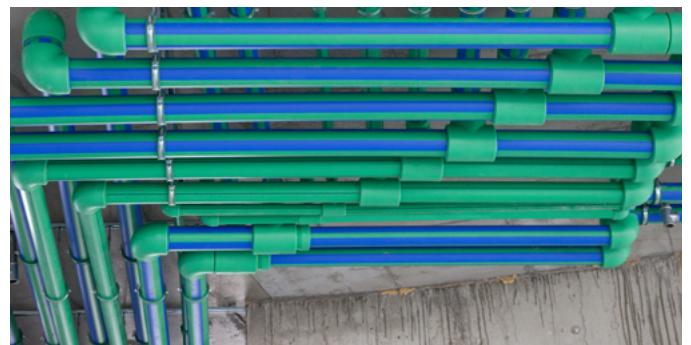

The connection of floor heating systems or the installation of radiator pipes up to the manifold can also be carried out with aquatherm blue pipe.





INDUSTRIAL FLOOR HEATING

Application areas

- Production halls
- Workshops
- Warehouses
- Logistics centers
- Maintenance hangars
- Exhibition halls
- Market halls
- Showrooms
- Cold storage warehouses with sub-freezing protection heater

Industrial buildings are planned by builders and architects in a way that preferably the entire volume of space is utilized.

TGA-installation must not impede the working processes. With component integrated surface heating systems the entire surface area is available to the user. That creates absolute space freedom and optimal utilization of the halls. Industrial surface heating offers a uniform temperature profile, low air speeds and low maintenance costs. It works at low temperatures and is characterized by rapid amortization.

The lifetime of the pipes corresponds to the life of the building!

Energy efficiency

Systems near to room temperature have the highest energy efficiency. Large transfer surfaces are required for the operation of heat pumps and the use of waste heat. Only industrial surface heating is suitable for these requirements.

Thermal insulation

Thermal insulation in industrial surface heating is usually placed under the concrete slab as perimeter insulation (adjacent to ground).

Depending on the static load it is chosen between extruder foam and foam glass plates. The insulation material for the perimeter insulation must be impervious to moisture and suitable for the loads occurring.

In calculating the U-value, according to DIN 4108, only layers up to the building sealing have to be included. Only when presenting a building approval for the selected building material the insulation value of the perimeter insulation can be included in the calculation of the U-value for the entire construction.

Construction types of floor slabs

Heating pipes can be integrated in the following types of concrete:

- Reinforced concrete with bottom reinforcement
- Reinforced concrete with bottom and top reinforcement
- Steel fiber concrete without reinforcement mats

Surface treatments (such as in vacuum concrete) are easily possible.

Construction types of industrial surface heating according to pipe fixing

Option A: Matt reinforced concrete, fixing of heating pipes by spring rails on the bottom reinforcement

Option B: Matt reinforced concrete, fixing of heating pipes by cable ties at the bottom reinforcement

Option C: Steel fiber concrete, fixing of heating pipes by spring rail on the film

Industrial surface heating must be subjected to a leak test. The pressure test is performed immediately prior to the concreting process. The test pressure of the water pressure test is at least 4 bar and not more than 6 bar. This pressure is to be kept during the concreting process.

The leak test must be documented. The test record is used as a confirmation for the architect and the constructor.

Concreting

The concrete is placed in a ready-mixed consistency with the transport hose, distributed, levelled and compacted.

Functional heating

Industrial surface heating has to be heated up after the placement of the concrete and top layer (functional heating). The earliest possible start of heating is dependent on the quality and thickness of the concrete and must be agreed with the concrete layer/structural engineer. The wait time is usually 28 days. The functional heating is simply a function test according to VOB DIN 18380.



SHIPBUILDING

Corrosion resistance against aggressive media and sea water with low pH-values makes aquatherm blue pipe the ideal pipe system in shipbuilding. For example for ballast and cooling systems or inert gas scrubber drains.

A major advantage of the saltwater resistant pipe systems is the fast processing and repair works that can be easily carried out, even on sea.

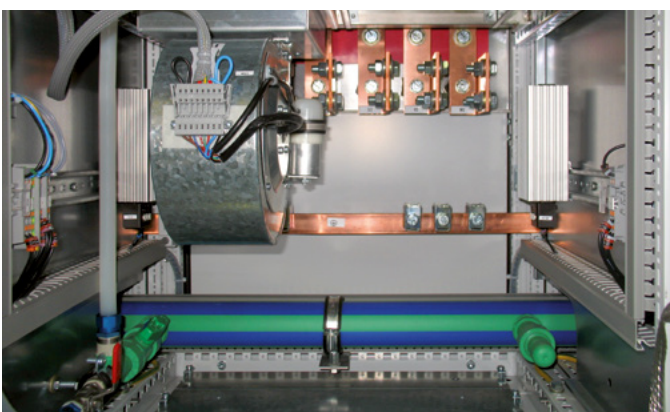
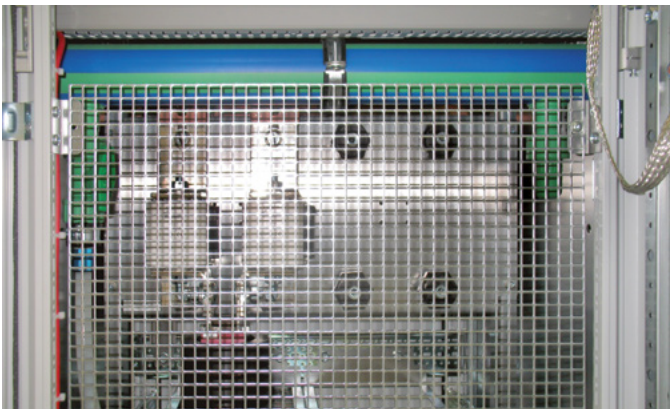

APPLICATION AREAS



UNDER SOIL HEATING

In order to keep a field with natural or artificial turf free of ice and snow, aquatherm offers a piping system for under soil heating that can be operated economically at the highest technical level, also from an ecological point of view.

This is possible thanks to the optimal combination of aquatherm green pipe and aquatherm blue pipe components.





ICE SURFACE COOLING

aquatherm blue pipe meets the high demands of professionally used ice rink areas.

The distribution pipes as well as the manifold connecting pipes are made from aquatherm blue pipe and connected by reverse return (Tichelmann-principle). The weld-in saddle technique, developed by aquatherm, is applied for the production of manifold branches.





COMPRESSED AIR

With aquatherm blue pipe you get a pipe system that guarantees the safe operation of your compressed air systems for decades. Whether for indoor or outdoor use, aquatherm blue pipe is characterized by its high compressive strength. Thanks to its lower weight compared to metallic pipes systems, even compressed air pipe system installation under hall roofs with high altitudes is easy. The corrosion-resistant polypropylene material is particularly resistant and can even be used for untreated compressed air containing oil.

SWIMMING POOL

Only impeccable water guarantees the swimming pool operator the security of offering his guests unlimited bathing enjoyment in the long term, and only a functioning heating system guarantees smooth, low-loss operation, if possible 52 weeks a year.

The pipe systems made by aquatherm offer both for water management and for heating technology a complete and reliable all-round supply on the foundation of a more than 45-year experience.





AGRICULTURE

In the agricultural sector, the possible applications of the aquatherm blue pipe system are manifold. It can be used not only for the air-conditioning of stables, but also for the transport of disinfectants in professional barn cleaning to ensure the hygiene and health of livestock and thus e.g. to improve milk quality.

The system is also suitable for irrigating fields and green areas or for transporting fertilizers in gardening and landscaping.

SPECIAL APPLICATIONS

EXAMPLE: SKI JUMPS

In order to ensure the same conditions on the jump-off platform of a ski jump even in changing weather conditions and thus equal opportunities for the start-up speed, aquatherm cooling grids are inserted directly under the run-up track. A glycol / water mixture is fed to them through aquatherm blue pipe pipes - this way the track is cooled evenly and constantly.

The ski jump is just one example of the many special applications of the aquatherm blue pipe system.



PART A: TOOLS AND ACCESSOIRES

The professional processing of aquatherm polypropylene medium pipes is made by the following tools for the connection of insulated pipes and fittings by socket welding or by butt-welding.

IMPORTANT!

Only use the original aquatherm welding equipment except devices and tools which are especially approved by aquatherm.

1. **aquatherm** manual welding device (800 W) without welding tools (Art. no. 9800050337) for medium pipes of dimension 16–63 mm
2. **aquatherm** manual welding device (1400W) without welding tools (Art. no. 9800050341) for medium pipes of dimension 50–125 mm
3. **aquatherm** welding tools for manual welding devices

Art. no. 9800050208	20 mm
Art. no. 9800050210	25 mm
Art. no. 9800050212	32 mm
Art. no. 9800050214	40 mm
Art. no. 9800050216	50 mm
Art. no. 9800050218	63 mm
Art. no. 9800050220	75 mm
Art. no. 9800050222	90 mm
Art. no. 9800050224	110 mm
Art. no. 9800050226	125 mm
4. **aquatherm** welding machine (1400W) incl. welding tools 50–125 mm (Art. no. 9800050148) for medium pipes of dimension 50–125 mm
5. **aquatherm** butt-welding-machines for medium pipes of dimension 160–630 mm
6. **aquatherm** electrical welding jig Art. no. 9800050151 for medium pipes of dimension 63–125 mm



Manual welding device 800W with welding tools 16–63 mm



Manual welding device 1400W with welding tools 50–125 mm

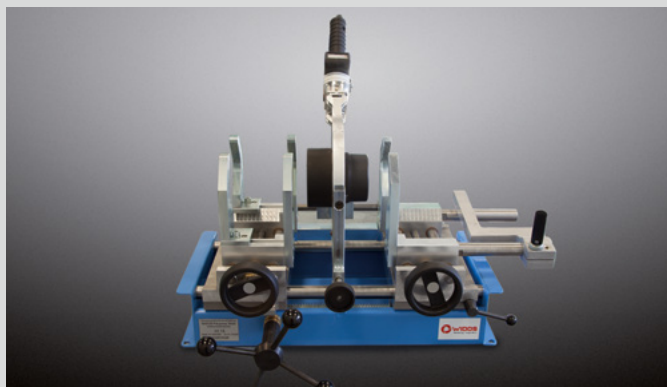

Welding machine

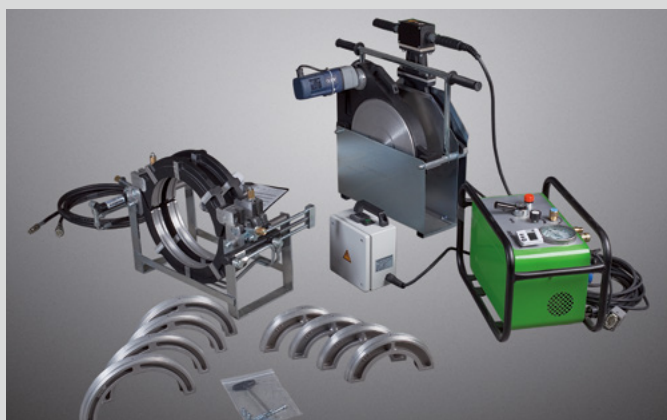

Butt-welding machine type Light and accessories



Electrical welding jig

PART A: ASSEMBLY OF WELDING TOOLS

1. aquatherm blue pipe und aquatherm green pipe are processed identically.
2. Assemble and tighten the cold welding tools manually.
3. Before fusing the distribution block, in which two connections are fused simultaneously, the welding tools have to be placed into the respective holes as described in the adjoining table A and drawing B.
4. All welding tools must be free from impurities. Check if they are clean before assembling. If necessary, clean the welding tools with a non fibrous, coarse tissue and with methylated spirit.
5. Place the welding tools on the welding device so that there is full surface contact between the welding tool and the heating plate. Welding tools over $\varnothing 40$ mm must always be fitted to the rear position of the heating plate.

Electric supply:

The power supply must coincide with the data on the type plate of the welding device and must be protected according to the local regulations. To avoid high power loss, the conductor cross-section of the used extension cables must be selected according to the power input of the welding devices.

6. Plug in the welding device. Depending on the ambient temperature it takes 10–30 minutes to heat up the heating plate.

A

Art. no.	Passage	Hole	Branch	Hole
1050025016	$\varnothing 25$ mm	A + E	$\varnothing 20$ mm	A + C
6090020006	$\varnothing 20$ mm	A + B	$\varnothing 16$ mm	A + C

B

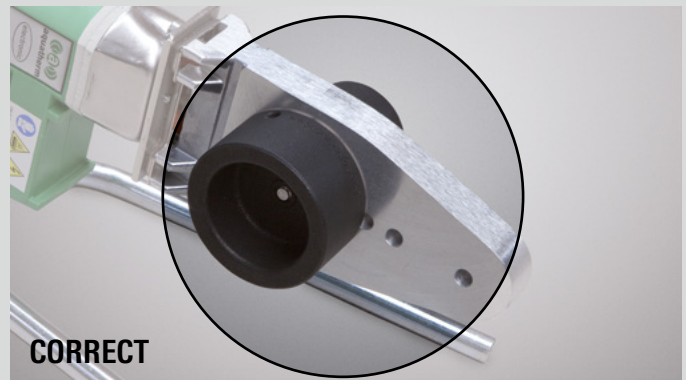
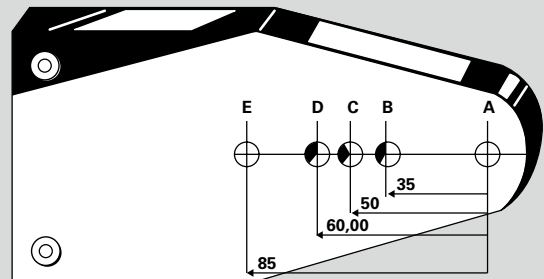

PART A: HEATING UP PHASE/HANDLING

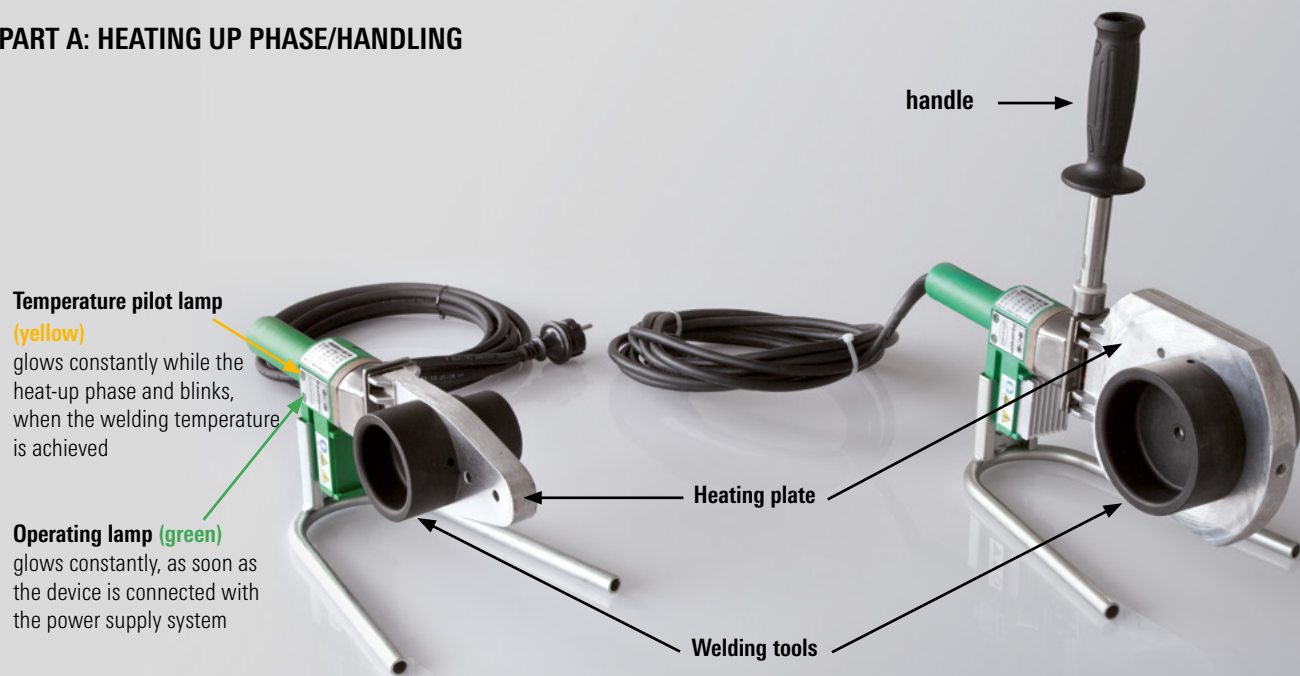

Temperature pilot lamp (yellow)

glows constantly while the heat-up phase and blinks, when the welding temperature is achieved

Operating lamp (green)

glows constantly, as soon as the device is connected with the power supply system

Heating plate

Welding tools

Heat-up phase

7. During the heating up phase tighten the welding tools carefully with the Allan key.

Take care that the tools completely contact the heating plate. Never use pliers or any other unsuitable tools, as this will damage the coating of the welding tools.

8. The temperature of 260 °C is required for the welding of aquatherm PP-R/PP-RP pipes.

According to DVS-Welding Guidelines the temperature of the welding device has to be checked at its tool before starting the welding process.

This can be done with a fast indicating surface thermometer.

ATTENTION:

First welding – earliest 5 minutes after reaching of the welding temperature. DVS 2207, Part 11.

Handling

9. A tool change on a heated device requires another check of the welding temperature at the new tool (after its heating up).

10. If the device has been unplugged, e.g. during longer breaks, the heating up process, has to be restarted (see item 6).

11. After use unplug the welding device and let it cool down. Water must never be used to cool the welding device, as this will destroy the heating resistances.

12. Protect aquatherm welding devices and tools against impurities. Burnt particles may lead to an incorrect fusion. The tools may be cleaned with aquatherm cleaning cloths, Art. no. 9800050193.

Always keep the welding tools dry.

13. After welding, do not lay the device on the Teflon coated tool, but put it down in the provided supporting stand.

14. For a perfect fusion, damaged or dirty welding tools must be replaced, as only impeccable tools guarantee a perfect connection.

15. Never attempt to open or repair a defective device. Return the defective device for repair.

16. Check the operating temperature of aquatherm welding devices regularly by means of suitable measuring instruments.

Guidelines

1. For the correct handling of welding machines the following must be observed: General Regulations for Protection of Labour and Prevention of Accidents and particularly the Regulations of the Employers' Liability Insurance Association of the Chemical Industry regarding Machines for the Processing of Plastics, chapter: „Welding Machines and Welding Equipment“.

2. For the handling of aquatherm welding machines, devices and tools please observe General Regulations DVS 2208 Part 1 of the German Association for Welding Engineering, Registered Society (Deutscher Verband für Schweißtechnik e. V.).

PART B: CHECKING OF DEVICES AND TOOLS

Check, if the aquatherm welding devices and tools comply with the guidelines "Fusion Part A".

The devices and tools used must have reached the required operating temperature of 260 °C for heating element socket welding or 210 °C for butt-welding. This requires according to "Fusion Part A, item 8" a separate test, which is indispensable (DVS-Welding Guidelines):

Suitable measuring instruments have to measure a temperature of up to 350 °C with a high accuracy.

NOTE:

aquatherm recommends the original aquatherm temperature measuring device Art. no. 9800050188.

PART B: PREPARATION FOR THE FUSION

1. Cut the pipe at right angles to the pipe axis. Only use aquatherm pipe cutters or other suitable cutting pliers. Take care that the pipe axis is free from burrs or cutting debris and remove where necessary.
2. Mark the welding depth at the end of the pipe with the enclosed pencil and template.
3. Mark the desired position of the fitting on the pipe and/or fitting. The markings on the fitting and the uninterrupted line on the pipe may be used as a guide.



Measurement of temperature at the aquatherm manual welding device (800W)



Measurement of temperature at the aquatherm welding machine



Measurement of temperature at the aquatherm butt-welding machine



Cutting of the pipe



Marking of the welding depth

PART B: HEATING OF PIPE AND FITTING

4. Push the end of the pipe, without turning, up to the marked welding depth into the welding tool.

pipe dimension mm	welding tool Art. no.
16 – 32	9800050336
16 – 63	9800050336
75 – 125	9800050341 / 9800050148

It is essential to observe the above mentioned heating times.

ATTENTION:

The heating time starts, when pipe and fitting have been pushed to the correct welding depth on the welding tool. Not before!

PART B: SETTING AND ALIGNMENT

5. After the required heating time quickly remove pipe and fitting from the welding tools. Join them immediately and without turning, until the marked welding depth is covered by the PP-bead from the fitting.

ATTENTION:

Do not push the pipe too far into the fitting, as this would reduce the bore and in an extreme case will close up the pipe.

6. The joint elements have to be fixed during the specified assembly time. Use this time to correct the connection. Correction is restricted to the alignment of pipe and fitting. Never turn the elements or align the connection after the processing time.

7. After the required cooling time the fused joint is ready for use.

The result of the fusion of pipe and fitting is a permanent material joining of the system elements. Connection technique with security for a life-time.

The fusion is subject to the following parameters

Pipe external- Ø	Welding depth	Heating time		Welding time	Cooling time
		sec. DVS	sec. AQT*		
20	14,5	5	8	4	2
25	16,0	7	11	4	2
32	18,0	8	12	6	4
40	20,5	12	18	6	4
50	23,5	18	27	6	4
63	27,5	24	36	8	6
75	30,0	30	45	8	8
90	33,0	40	60	8	8
110	37,0	50	75	10	8
125	40,0	60	90	10	8

ATTENTION: sec. AQT* heating times recommended by aquatherm at ambient temperatures below +5 °C.

The General Guidelines for Heated Socket Welding acc. to DVS 2207, Part 11 are applied hereupon.



Heating-up of pipe and fitting



Joining, fixing and...



...aligning

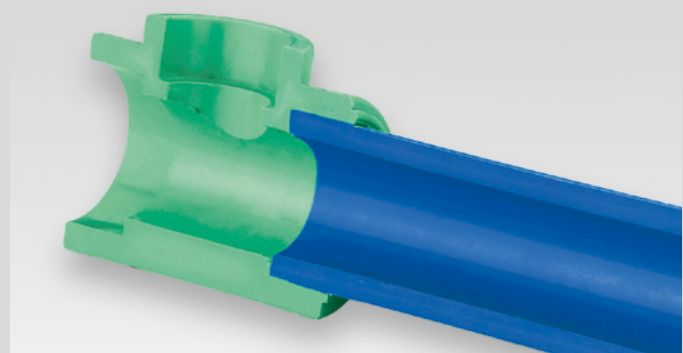

The result: a permanent connection!

Dimension 160–630 mm:

The dimension 160–630 mm are joined by butt-welding.

Detailed information page 64 + 65.

The General Guidelines for Heated Tool Socket Welding according to DVS 2207 Part 11 are applied hereupon.

PART B: UNIVERSAL PEELING TOOLS

By using the aquatherm universal peeling tools the end pieces of the aquatherm blue pipe OT and UV can be peeled. By the uniform removal of the outer layer of the pipe any extension of the pipe system by electrofusion socket or fitting is possible. The universal peeling tools are available in the sizes Ø 20–125 mm (Art. no. 9800050479 – 9800050488). The peeling process is done either mechanically or manually. For the mechanical processing two attachment plates for pipe sizes Ø 20–63 mm (Art. no. 9800050499) and Ø 75–125 (Art. no. 9800050500) mm are available. For the mechanical processing of the electrofusion sockets the peeler is extended by an attachment (Art. no. 9800050489–9800050498). The power drill should have a high torque.

1. INSTRUCTIONS FOR THE MECHANICAL PEELING PROCESS

- 1.1. The attachment plate is clamped with the hexagon bolt in the power drill.
- 1.2. The peeler is fixed with its screws in the slot matching the diameter of the attachment plate and rotated clockwise so that the peeler adheres to the attachment plate.
- 1.3. The peeling tool clamped on the chuck is set by the lead to the end of the pipe.
- 1.4. The peeling process starts with rotation of the peeling tool upon slight force in axial direction. The peeling operation is completed when the attachment plate strikes against the pipe end.
- 1.5. The pipe now can be welded by socket welding method.

2. INSTRUCTIONS FOR THE MECHANICAL PEELING PROCESS FOR ELECTROFUSION SOCKETS

- 2.1. The extension is centered with the peeler through the superimposed chamfer fit and fastened with three Allen screws.
- 2.2. The attachment plate is clamped with the hexagon bolt in the power drill and connected with the peeling tool (see photo 1.2.).
- 2.3. The peeling process starts with rotation of the peeling tool upon slight force in axial direction. The peeling operation is completed when the carrier plate strikes against the pipe end.
- 2.4. The peeling tool is withdrawn from the pipe and the E-socket welding process can start.

3. PEELING INSTRUCTIONS FOR MANUAL PEELING

- 3.1. For the manual peeling two handles are mounted at the peeling tool.
- 3.2. The peeling tool is pushed onto the untreated pipe up to the stop.
- 3.3. The peeling tool is turned clockwise as long as the marked peeling depth (see table on the next page) is reached.
- 3.4. If the specified/marked peeling depth (see table on the next page) is reached, the peeling tool is removed and the socket welding process can start. If the electric socket can be used as a sliding sleeve, the peeling depth for the electric socket welding (see table) must be doubled.



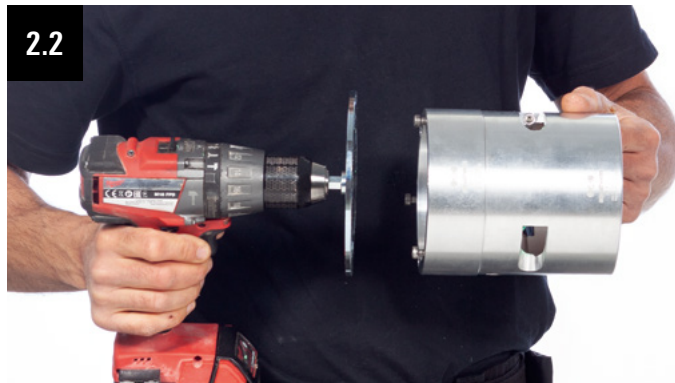

**TABLE OF PEELING DEPTH:
SOCKET AND ELECTRIC SOCKET WELDING**

Diameter	Peeling depth Socket welding	Peeling depth Electric socket welding
ø 20	16 mm	39 mm
ø 25	20 mm	43 mm
ø 32	22 mm	45 mm
ø 40	25 mm	50 mm
ø 50	28 mm	56 mm

Diameter	Peeling depth Socket welding	Peeling depth Electric socket welding
ø 63	32 mm	65 mm
ø 75	34 mm	69 mm
ø 90	37 mm	77 mm
ø 110	42 mm	85 mm
ø 125	44 mm	90 mm

PART C: WELD-IN SADDLES

aquatherm weld-in saddles are available for pipe outer diameter of 40–630 mm.

Weld in saddles are used for

- Branch connections in existing installations
- The substitution of a reduction-tee
- Branch connections in risers
- Sensor wells, etc.

1. Before starting the welding process, check whether the aquatherm welding devices and tools comply with the requirements of "Fusion Part A".
2. The first step is to drill through the pipe wall at the intended outlet point by using the aquatherm drill (Art. no. 9800050940 – 9800050948).

3. IMPORTANT!

Only the oxygen barrier layer of the aquatherm blue pipe of Art. no. 2112020006 – 2114250030 must be removed with the mentioned aquatherm special peeling drills mentioned in the table beside.

For this the special peeling drill is inserted into the bore hole and swayed 2–3 times with light pressure and low rotating speed between the pipe walls until the oxygen barrier layer is completely peeled off.

The UV-layer is removed in the same way.

Remove burrs, debris and other dirt with a chamfering tool or the aquatherm cleaning wipes. Do not touch the peeled surface any more and protect it from new pollution.

4. The welding device/saddle welding tool must have reached the required operating temperature of 260 °C (check with reference to "Fusion Part B, item 2").
5. The welding surfaces have to be clean and dry.
6. Insert the heating tool on the concave side of the weld in saddle tool into the hole drilled in the pipe wall until the tool is completely in contact with the outer wall of the pipe. Next the weld-in saddle tool is inserted into the heating sleeve until the saddle surface is up against the convex side of the welding tool. The heating time of the elements is generally 30 seconds.
7. After the welding tool has been removed, the weld-in saddle tool is immediately inserted into the heated, drilled hole. Then the weld-in saddle should be pressed on the pipe for about 15 seconds. After being allowed to cool for 10 minutes the connection can be exposed to its full loading. The appropriate branch pipe is fitted into the sleeve on the aquatherm weld-in saddle using conventional fusion technology.

By fusing the weld-in saddle with the pipe outer surface and the pipe inner wall the connection reaches highest stability.



Drilling through the pipe wall



Removal of the oxygen barrier layer in case of the aquatherm blue pipe OT and of the UV layer in case of the aquatherm UV-pipe

aquatherm saddle peeling tools for	Art. no.	Dimension
aquatherm blue pipe	9800050921	for weld-in saddles ø 20 & 25 mm
OT-pipes	9800050922	for weld-in saddles ø 32 mm
aquatherm blue pipe	9800050924	for weld-in saddles ø 40 mm
UV-pipes	9800050926	for weld-in saddles ø 50 mm
ø 50–125 mm	9800050928	for weld-in saddles ø 63 mm

aquatherm saddle peeling tools for	Art. no.	Dimension
aquatherm blue pipe	9800050421	for weld-in saddles ø 20 & 25 mm
OT-pipes	9800050422	for weld-in saddles ø 32 mm
aquatherm blue pipe	9800050424	for weld-in saddles ø 40 mm
UV-pipes	9800050426	for weld-in saddles ø 50 mm
ø 160–250 mm	9800050428	for weld-in saddles ø 63 mm



The welding tool is inserted into the pipe wall ...



...heating-up of the elements



joining

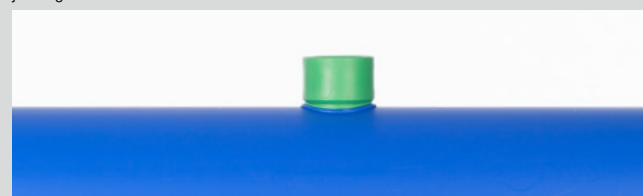

Ready!

PART C: WELD-IN SADDLES

Art. no.	Dimension	Drill			Special peeling drill ¹	Tool	
		D mm	d mm	l mm			
1030050003	50/20 mm	50	20	27.0	9800050940	9800050921	9800050616
1030050004	50/25 mm	50	25	28.0	9800050940	9800050921	9800050616
1030063005	63/20 mm	63	20	27.0	9800050940/9800050941	9800050921	9800050619
1030063006	63/25 mm	63	25	28.0	9800050940/9800050941	9800050921	9800050619
1030063007	63/32 mm	63	32	30.0	980009800050942	9800050922	9800050620
1030075008	75/20 mm	75	20	27.0	9800050940/9800050941	9800050921	9800050623
1030075009	75/25 mm	75	25	28.0	9800050940/9800050941	9800050921	9800050623
1030075010	75/32 mm	75	32	30.0	9800050942	9800050922	9800050624
1030075011	75/40 mm	75	40	34.0	9800050944	9800050924	9800050625
1030090012	90/20 mm	90	20	27.0	9800050940/9800050941	9800050921	9800050627
1030090013	90/25 mm	90	25	28.0	9800050940/9800050941	9800050921	9800050627
1030090014	90/32 mm	90	32	30.0	9800050942	9800050922	9800050628
1030090015	90/40 mm	90	40	34.0	9800050944	9800050924	9800050629
1030110016	110/20 mm	110	20	27.0	9800050940/9800050941	9800050921	9800050631
1030110017	110/25 mm	110	25	28.0	9800050940/9800050941	9800050921	9800050631
1030110018	110/32 mm	110	32	30.0	9800050942	9800050922	9800050632
1030110019	110/40 mm	110	40	34.0	9800050944	9800050924	9800050634
1030110020	110/50 mm	110	50	34.0	9800050946	9800050926	9800050635
1030125021	125/20 mm	125	20	27.0	9800050940/9800050941	9800050921	9800050636
1030125022	125/25 mm	125	25	28.0	9800050940/9800050941	9800050921	9800050636
1030125023	125/32 mm	125	32	30.0	9800050942	9800050922	9800050638
1030125024	125/40 mm	125	40	34.0	9800050944	9800050924	9800050640
1030125025	125/50 mm	125	50	34.0	9800050946	9800050926	9800050642
1030125026	125/63 mm	125	63	38.0	9800050948	9800050928	9800050644
1030160027	160/20 mm	160	20	27.5	9800050940/9800050941	9800050421	9800050648
1030160028	160/25 mm	160	25	28.5	9800050940/9800050941	9800050421	9800050648
1030160029	160/32 mm	160	32	30.0	9800050942	9800050422	9800050650
1030160030	160/40 mm	160	40	34.0	9800050944	9800050424	9800050652
1030160031	160/50 mm	160	50	34.0	9800050946	9800050426	9800050654
1030160032	160/63 mm	160	63	38.0	9800050948	9800050428	9800050656
1030160033	160/75 mm	160	75	42.0	9800050987**	-	9800050657
1030160034	160/90 mm	160	90	45.0	9800050988**	-	9800050658
1030250035	200-250/20 mm	200-250	20	27.5	9800050941	9800050421	9800050660 / 9800050672
1030250036	200-250/25 mm	200-250	25	28.5	9800050941	9800050421	9800050660 / 9800050672
1030250037	200-250/32 mm	200-250	32	30	9800050942	9800050422	9800050662 / 9800050674
1030200038	200/40 mm	200	40	34	9800050944	9800050424	9800050664
1030200039	200/50 mm	200	50	34	9800050946	9800050426	9800050666
1030200040	200/63 mm	200	63	37.5	9800050948	9800050428	9800050668
1030200041	200/75 mm	200	75	42.0	9800050987**	-	9800050667
1030200042	200/90 mm	200	90	42.0	9800050988**	-	9800050669
1030200043	200/110 mm	200	110	49.0	9800050989**	-	9800050670
1030200044	200/125 mm	200	125	55.0	9800050990**	-	9800050671
1030250045	250/40 mm	250	40	34	9800050944	9800050424	9800050672
1030250046	250/50 mm	250	50	34	9800050946	9800050426	9800050678
1030250047	250/63 mm	250	63	37.5	9800050948	9800050428	9800050680
1030250048	250/75 mm	250	75	42.0	9800050987**	-	9800050682
1030250049	250/90 mm	250	90	45.0	9800050988**	-	9800050684
1030250050	250/110 mm	250	110	49.0	9800050989**	-	9800050686
1030250051	250/125 mm	250	125	55.0	9800050990**	-	9800050688
1030315052	315/63 mm	315	63	37.5	9800050948	-	9800050690
1030315053	315/75 mm	315	75	42.0	9800050987**	-	9800050692
1030315054	315/90 mm	315	90	45.0	9800050988**	-	9800050694
1030315055	315/110 mm	315	110	49.0	9800050989**	-	9800050696
1030315056	315/125 mm	315	125	55.0	9800050990**	-	9800050698
1030355058	355/90 mm	355	90	45.0	9800050988**	-	9800050716
1030355059	355/110 mm	355	110	49.0	9800050989**	-	9800050718
1030355060	355/125 mm	355	125	55.0	9800050990**	-	9800050720
1033315073	315/160 mm	315	160	80.0	9800050991**	-	9800050699
1033355074	355/160 mm	355	160	80.0	9800050991**	-	9800050722
1034315057	315/160 mm	315	160	80.0	9800050991**	-	9800050699
1034355061	355/160 mm	355	160	-	9800050991**	-	9800050722
1030500062	400-500/75 mm	400-500	75	-	9800050987**	-	9800050728
1030450063	400-450/110 mm	400-500	110	-	9800050989**	-	9800050736
1030400064	400/125 mm	400	125	-	9800050990**	-	9800050742
1030500065	400-500/90 m	400-500	90	-	9800050988**	-	9800050732
1030500066	450-500/125 m	400-500	125	-	9800050990**	-	9800050744
1030630067	400-630/63 mm	400	63	-	9800050948	-	9800050726
1030560068	500-560/110 mm	500-560	110	-	9800050989**	-	9800050738
1030630069	560-630/75 mm	560-630	75	-	9800050987**	-	9800050730
1030630070	560-630/90 mm	560-630	90	-	9800050988**	-	9800050734
1030630071	560-630/125 mm	560-630	125	-	9800050990**	-	9800050746
1030630072	630/110 mm	630	110	-	9800050989**	-	9800050740

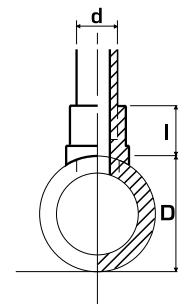

1) only for aquatherm blue pipe OT fibre composite pipes Art. no. 2112020006-2114250030
 ** only in conjunction with the aquatherm hole saw system

PART C: WELD-IN SADDLES

Art. no.	Dimension	D	d	l	Sensorwels	Drill	Special peeling drill*	Tool
		mm	mm	mm	Art. no.	Art. no.	Art. no.	Art. no.
1030040100	40/25 x 1/2" f	40	1/2"	39,0	14	9800050940	9800050921	9800050614
1030050106	50/25 x 1/2" f	50	1/2"	39,0	14	9800050940	9800050921	9800050616
1030063112	63/25 x 1/2" f	63	1/2"	39,0	14	9800050940/9800050941	9800050921	9800050619
1030075118	75/25 x 1/2" f	75	1/2"	39,0	14	9800050940/9800050941	9800050921	9800050623
1030090126	90/25 x 1/2" f	90	1/2"	39,0	14	9800050940/9800050941	9800050921	9800050627
1030110134	110/25 x 1/2" f	110	1/2"	39,0	14	9800050940/9800050941	9800050921	9800050631
1030125142	125/25 x 1/2" f	125	1/2"	39,0	14	9800050940/9800050941	9800050921	9800050636
1030160150	160/25 x 1/2" f	160	1/2"	39,0	14	9800050940/9800050941	9800050921	9800050648
1030250158	200–250/25 mm x 1/2" f	200–250	1/2"	39,0	14	9800050941	9800050921	9800050660/9800050672
1030040101	40/25 x 3/4" f	40	3/4"	39,0	16	9800050940	9800050921	9800050614
1030050107	50/25 x 3/4" f	50	3/4"	39,0	16	9800050940	9800050921	9800050616
1030063113	63/25 x 3/4" f	63	3/4"	39,0	16	9800050940/9800050941	9800050921	9800050619
1030075119	75/25 x 3/4" f	75	3/4"	39,0	16	9800050940/9800050941	9800050921	9800050623
1030090127	90/25 x 3/4" f	90	3/4"	39,0	16	9800050940/9800050941	9800050921	9800050627
1030110135	110/25 x 3/4" f	110	3/4"	39,0	16	9800050940/9800050941	9800050921	9800050631
1030125143	125/25 x 3/4" f	125	3/4"	39,0	16	9800050940/9800050941	9800050921	9800050636
1030160151	160/25 x 3/4" f	160	3/4"	39,0	16	9800050940/9800050941	9800050921	9800050648
1030250159	200–250/25 mm x 3/4" f	200–250	3/4"	39,0	16	9800050941	9800050921	9800050660/9800050672
1030075120	75/32 x 1" f	75	1"	43,0	20	9800050942	9800050922	9800050624
1030090128	90/32 x 1" f	90	1"	43,0	20	9800050942	9800050922	9800050628
1030110136	110/32 x 1" f	110	1"	43,0	20	9800050942	9800050922	9800050632
1030125144	125/32 x 1" f	125	1"	43,0	20	9800050942	9800050922	9800050638
1030160152	160/32 x 1" f	160	1"	43,0	20	9800050942	9800050922	9800050650
1030250160	200–250/32 mm x 1" f	200–250	1"	43,0	20	9800050942	9800050922	50662/50674

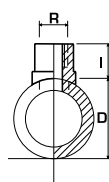

Art. no.	Dimension	D	d	l	Drill	Special peeling drill*	Tool
		mm	mm	mm	Art. no.	Art. no.	Art. no.
1030040102	40/25 x 1/2" m	40	1/2"	55,0	9800050490	9800050921	9800050614
1030050108	50/25 x 1/2" m	50	1/2"	55,0	9800050490	9800050921	9800050616
1030063114	63/25 x 1/2" m	63	1/2"	55,0	9800050490/9800050941	9800050921	9800050619
1030075121	75/25 x 1/2" m	75	1/2"	55,0	9800050490/9800050941	9800050921	9800050623
1030090129	90/25 x 1/2" m	90	1/2"	55,0	9800050490/9800050941	9800050921	9800050627
1030110137	110/25 x 1/2" m	110	1/2"	55,0	9800050490/9800050941	9800050921	9800050631
1030125145	125/25 x 1/2" m	125	1/2"	55,0	9800050490/9800050941	9800050921	9800050636
1030160153	160/25 x 1/2" m	160	1/2"	55,0	9800050490/9800050941	9800050921	9800050648
1030040103	40/25 x 3/4" m	40	3/4"	56,0	9800050490	9800050921	9800050614
1030050109	50/25 x 3/4" m	50	3/4"	56,0	9800050490	9800050921	9800050616
1030063115	63/25 x 3/4" m	63	3/4"	56,0	9800050490/9800050941	9800050921	9800050619
1030075122	75/25 x 3/4" m	75	3/4"	56,0	9800050490/9800050941	9800050921	9800050623
1030090130	90/25 x 3/4" m	90	3/4"	56,0	9800050490/9800050941	9800050921	9800050627
1030110138	110/25 x 3/4" m	110	3/4"	56,0	9800050490/9800050941	9800050921	9800050631
1030125146	125/25 x 3/4" m	125	3/4"	56,0	9800050490/9800050941	9800050921	9800050636
1030160154	160/25 x 3/4" m	160	3/4"	56,0	9800050490/9800050941	9800050921	9800050648

* only for aquatherm blue pipe OT fibre composite pipes

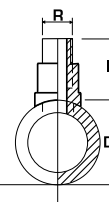

PART C: WELD-ON SADDLE

Drilling of aquatherm PP pipes with the hot tapping tool Art. no. 9800050890 under pressure.

The aquatherm weld-on saddle set (consisting of ball valve, pipe and saddle in the dimensions 40 mm and 63 mm) is used for the additional installation of branch connections.

The polypropylene pipes aquatherm green pipe and blue pipe with the pipe structure S, MF and MF UV in the dimensions 75–630 mm can be drilled under pressure.

SAFETY INSTRUCTION:

The medium pressure (e.g. water) in the main pipe of 6 bar and the medium temperature of max. 60 °C must not be exceeded.

1. Preparation and fusion

After removal of the oxide layer on the main pipe and the cleaning of the welding surfaces, the welding device is placed with the weld-on saddle tool on the surfaces to be welded. Under gentle pressure and a warm-up time of 90 sec. an even bead must be there on the welding surfaces. After a warm-up time, the component is placed quickly on the main pipe. The component is fixed and aligned on the main pipe for max. 15 seconds. The connection is fully able to work under pressure after a cooling time of 15 minutes.

2. Assembly of the hot tapping tool

The hot tapping tool is screwed onto the component with the retracted drill rod, which is secured by the clamping claw. The screw connection on the ball valve is tightened by hand. After the ball valve has been opened, the welded component in conjunction with the hot tapping tool is tested for leaks with water or air.

3. Drilling process

When the clamping claw is loosened, the drill rod is pushed until the drilling tool contacts the pipe. Depending on the branch size, the appropriate feed rate must be set. The drilling is carried out by actuating the ratchet handle and simultaneously by giving a manually sensitive feed on the feed handles. After completion of the drilling and the release of the clamping claw, the drill rod is led back to the stop by hand. Caution: The drill rod can rebound by the pressure in the pipe. The ball valve is then closed and the hot tapping device is relieved of pressure.

4. Disassembly

Detach the hot tapping device by holding the screw on the ball valve and remove it from the component. Pull the drill rod out of the hot tapping device and screw the drilling tool from the drill rod using a suitable wrench or armature tongs.



Hot tapping device Art.no. 9800050890



1. Welding-on of weld-on saddle set onto the main pipe



2. Assembly of the hot tapping tool onto the component



3. Start of the drilling process



4. Removal of the drilling residues out of the drilling tool

PART D: WELDING JIG (HITCH)

Note

The following description of the electric welding jig applies to the type of the year 2013.

Operation and fusion

With the help of the electric welding jig, all aquatherm polypropylene pipes and fittings in dimensions from 63 to 125 mm are in a very simple manner without any effort welded together.

The welding jig simplifies the welding of pipes and fittings under ceilings, in narrow shafts and other hard-to-reach places.



Preparation for the fusion

Mark the welding depth with the included green marking template on the pipe end. (Fig. 1). In addition, the clamping depth is measured 2 cm from the welding depth marking and marked again. (Fig. 2+3).

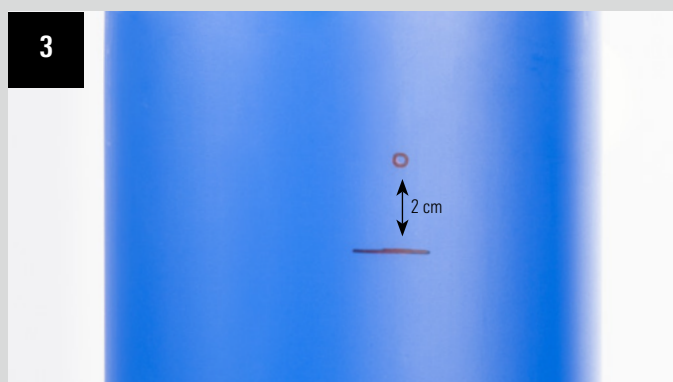

FUSION

The welding jig is now placed on the fitting or pipe to be welded with the clamping jaws. (Fig. 4) .

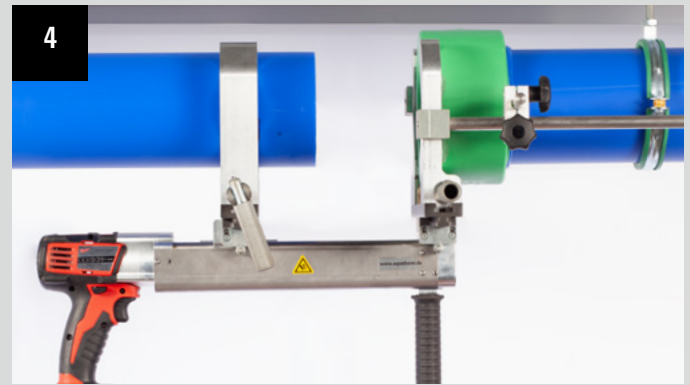

The two arrows of the jaws and the machine must be flush with each other. The jaws are to be fixed with the help of the clamping device (Fig. 5).

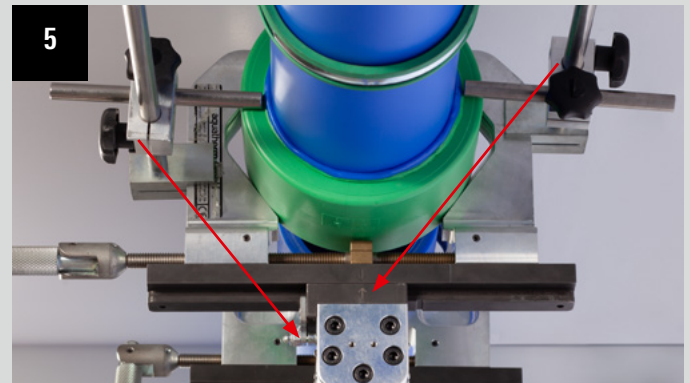

Align the pipe so that the rear marking is flush with the inner edge of the clamping jaw. The front marking identifies the welding depth (Fig. 6).

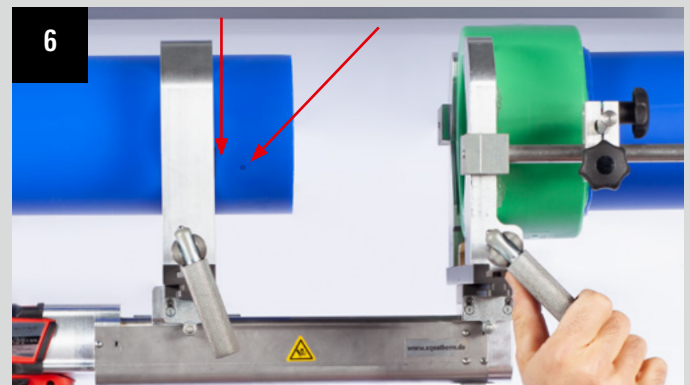

Lock pipe and fitting by using the front adjusting screws. (Fig. 7).

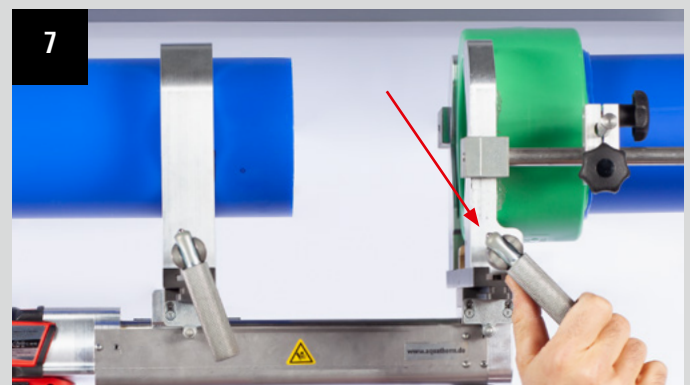

Never clamp so tight that deformations appear. Additionally, with the fitting support, all fittings are supported. The support is mounted on the clamping jaw for fittings. (Fig. 8).

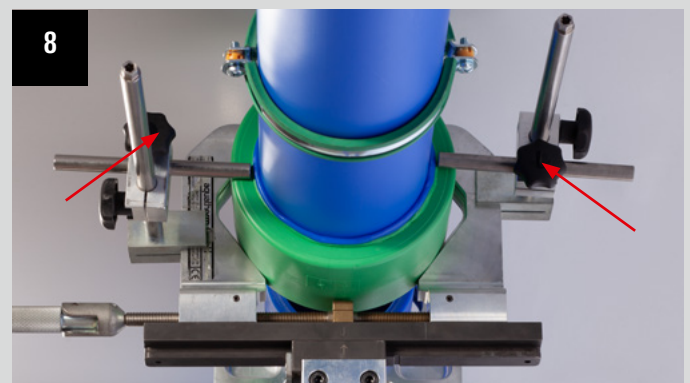

Fusion

Hold the welding device between pipe and fitting and ride machine carriage in batches together (pay attention to the welding depth).

Basically the jaws must be released after the insertion of pipe and fitting in the welding tool by a short return of the machine (3–7 mm)! The jaws must always be parallel to each other. (Fig. 9 +10).

After finishing of the warm-up drive the machine carriage apart and remove the welding device. (Fig. 11).

Ride the jaws together again and release the clamping jaws again by a short return of the machine (3–7 mm). (Fig. 12).

CAUTION:

Jaws may be released only after the specified cooling time!

Pipe and fitting are now joined by fusion to a material unit. (Fig. 13).

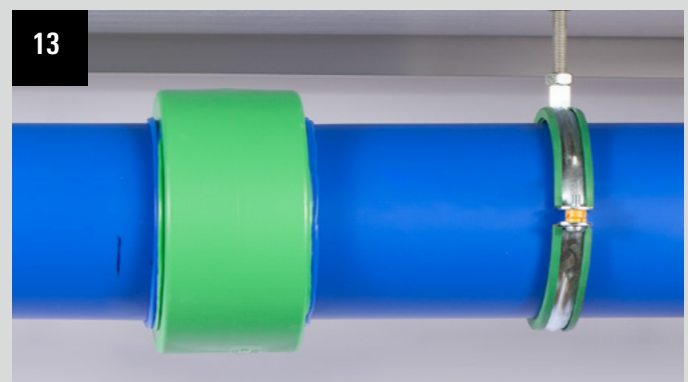
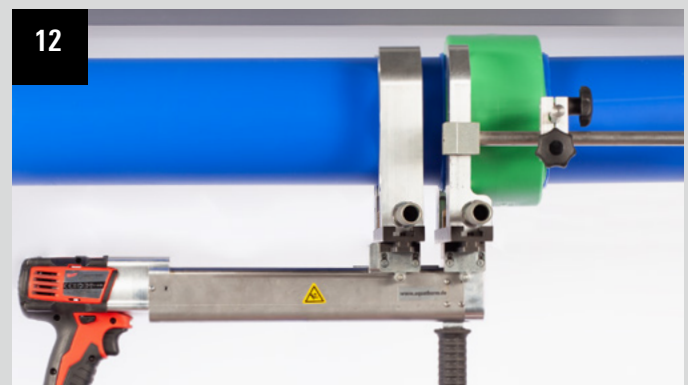
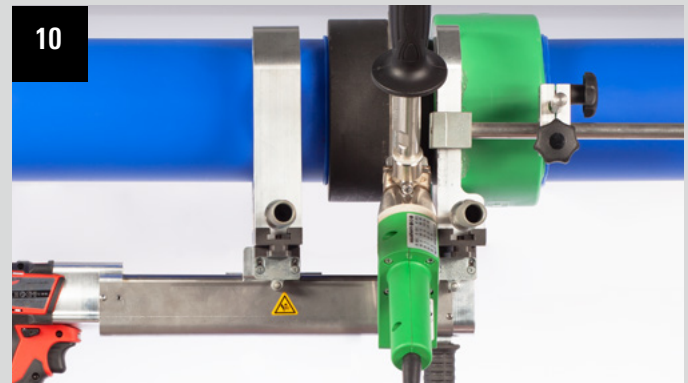

The fusion is subject to the following parameters

Pipe external- Ø	Welding depth	Heating time		Welding time	Cooling time
		sec. DVS	sec. AQT*		
50	23,5	18	27	6	4
63	27,5	24	36	8	6
75	30,0	30	45	8	8
90	33,0	40	60	8	8
110	37,0	50	75	10	8
125	40,0	60	90	10	8

ATTENTION: sec. AQT* heating times recommended by aquatherm at ambient temperatures below +5 °C.

The General Guidelines for Heated Socket Welding according to DVS 2207, Part 11 are applied hereupon.

PART E: AQUATHERM WELDING MACHINE

for stationary processing 50–125 mm

precise pre-assembly and facilitation by hand creek

clamping jaws 50–125 mm, tools 50–125 mm,

Scope of supply:

wooden transport box, slide with sub-construction, clamping jaws 50–125 mm, welding tools 50–125 mm, stay with rolls

For welding of aquatherm blue pipe a welding temperature of 260 °C at the welding tools is necessary (see page 47).

Instructions for use can be taken from the attached operation manual.

The fusion is subject to the following parameters

Pipe external- Ø	Welding depth	Heating time		Welding time	Cooling time
		sec. DVS	sec. AQT*	sec.	min.
50	23,5	18	27	6	4
63	27,5	24	36	8	6
75	30,0	30	45	8	8
90	33,0	40	60	8	8
110	37,0	50	75	10	8
125	40,0	60	90	10	8

PART E: WELDING MACHINE PRISMA-LIGHT

welding machine prisma-light with heating plate without tools

clamping fixture for fixing the prisma-light e. g. at the work bench

1. Check machine: temperature lamp blinks after reaching the welding temperature (260 °C), adjust clamping jaws 63–125 mm coarsely. Mark welding depth with the template at the pipe.
2. Fix the fitting against the clamping jaws.
3. Place the pipe loose in the opposite clamping jaws.
4. Position the welding device centrally to the pipe-fitting axis and remove it.
5. Lock the front calibration knob and drive up the slide as far as it will go.
6. In this position push the pipe against the fitting and fix it with the clamping jaws.
7. Regulate the welding time according to the table on page 57, place the welding device and push the fitting and pipe slowly as far as it will go up to the marking.
8. The heating time starts when pipe and fitting are completely pushed on the tool. When heating time is complete, return the slide, remove the heating device quickly and join the pipe and fitting.
9. Consider cooling times from the table on page 57.

More detailed information can be found in the enclosed operating manuals.

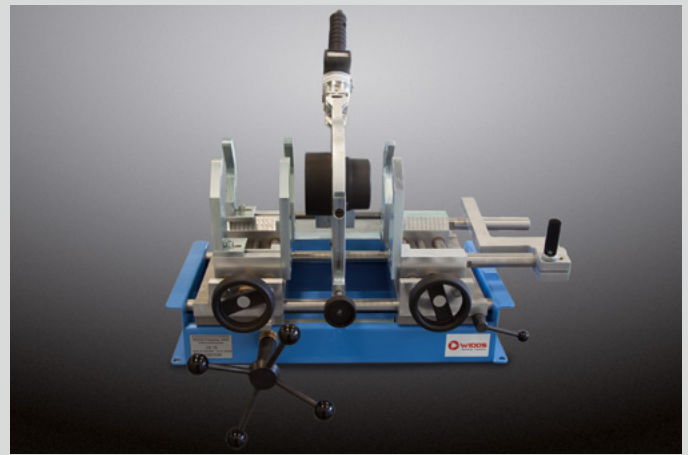

ATTENTION: sec. AQT* heating times recommended by aquatherm at ambient temperatures below +5 °C.

The General Guidelines for Heated Socket Welding according to DVS 2207, Part 11 are applied hereupon.

*heating times recommended by aquatherm at ambient temperatures below + 5 °C

Dimension 160–630 mm:

The dimension 160–630 mm are joined by butt-welding.

Detailed information on page 64 + 65.

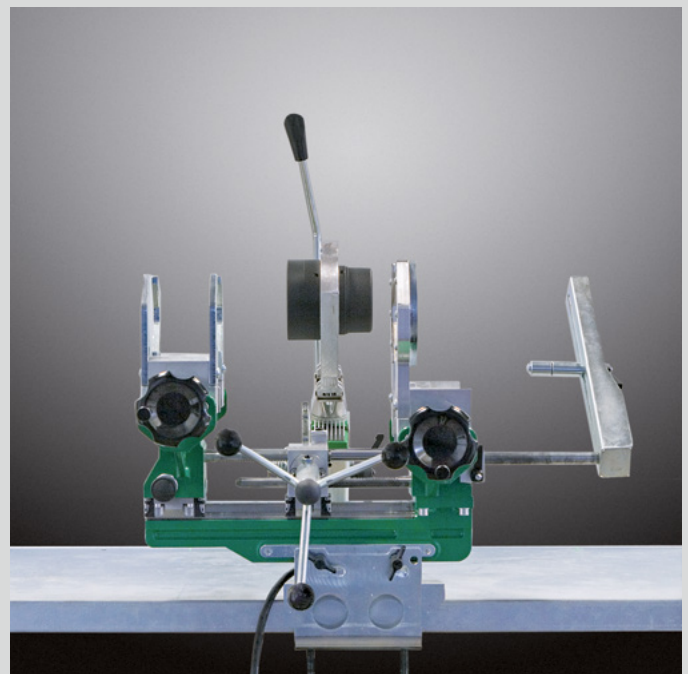

PART F: ELECTROFUSION DEVICE

Fusion

The aquatherm electrofusion device was specially developed for electrofusion sockets from Ø 20–250 mm.

The fusion of 160–250 mm aquatherm blue pipe MF OT with the electrofusion socket is not possible.

Technical information:

supply voltage: 230 V (nominal voltage)

nominal capacity: 2.800 VA, 80 % ED

rated frequency: 50 Hz–60 Hz

protection class: IP 54

1. General and inspection

Cleanliness is – besides correct workmanship – the most important precondition for a correct fusion. For keeping the sockets clean do not unwrap them before processing.

The pipe surface must also be clean and undamaged. Deformed pipe ends must be cut off.

All parts of the system to be fused as well the temperature sensors shall have the same temperature (e.g. sun radiation or unadapted storing may cause differences in temperature!) within the acceptable range of temperature (e.g. +5 °C to 40 °C according to DVS 2207).

2. Preparation

Follow carefully the order of working steps!

Preparation is one of the most important steps of the electrofusion process!

2.1 Cut the ends of the pipes rectangularly and deburr them thoroughly

2.2 Clean and dry the ends of the pipes at the necessary length

2.3 Mark the depth of aquatherm electrofusion socket on the end of the pipe



aquatherm electrofusion device Ø 20–250 mm



aquatherm electrofusion socket



aquatherm peeling tool (Art. no. 9800050558–9800050572, up to 90 mm)
(from 110–250 mm: Art. no. 9800050574 / 9800050576 / 9800050580 / 9800050592
(without picture))

Welding depth up to 250 mm													
Ø	20	25	32	40	50	63	75	90	110	125	160	200	250
ET	35,0	39,0	40,0	46,0	51,0	59,0	65,0	72,5	80,0	86,0	93,0	105,0	125,0

PART F: ELECTROFUSION DEVICE

Fusion

Peel the surface of both pipes up to the marks thoroughly with a peeling tool (use the aquatherm peeling tool with the respective pipe diameter)

IMPORTANT!

Before the fusion peel off the oxygen barrier layer of the aquatherm blue pipe OT and the UV-layer of the fibre composite pipe UV completely to the stop by using the appropriate double peeling tools considering the pipe diameter.

By turning the adjusting screw clockwise to the stop, the peeling tools can be adjusted into small depths (sockets), by turning them counter clockwise up to the stop they can be adjusted into big peeling depth (electrofusion sockets), see page 48.

Clean again thoroughly

Without complete peeling of the fusion surface a homogeneous and tight welding connection is not assured. Damages of the surface like axial grooves and scratches are not accepted in the fusion zone. Never touch peeled surfaces and protect them against dirt and grease. Start the fusion process within 30 mins after peeling.

3. Assembling the electrofusion sockets

Avoid soiling and fix all parts securely!

3.1 Open the protective wrapping of the aquatherm electrofusion sockets (cut with knife along the edge of the bore), leaving the rest of the foil intact. Clean the inside of the entire fitting carefully with aquatherm cleaning wipes. The socket must be dry after cleaning. Assemble the fitting within 30 mins after opening of the protective foil.

3.2 Push the aquatherm electrofusion sockets on the clean and dry end of the pipe (up to the marked depth). Use pressing clamps if necessary.



Cut the pipes to be welded, peel, clean and dry thoroughly with a lint-free cloth or paper



Clean the electrofusion socket's inner surface with a lint-free cloth or paper. Remove moisture that may occur **immediately before the welding process** again.



Push the electrofusion socket onto the pipe end

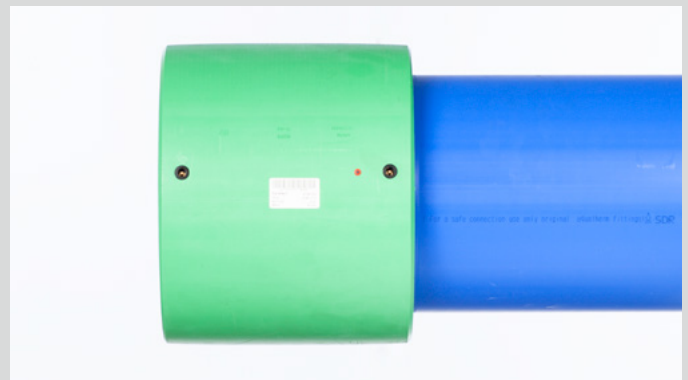

PART F: ELECTROFUSION DEVICE

Remove the protective foil completely and push the other prepared, dry pipe end into the aquatherm electrofusion socket as far as it will go.

Leave the pipes, free from bending stress or own weight, within the aquatherm electrofusion socket. the socket is movable at both pipe ends after assembling. The air gap has to be even around the circumference. Pipes and fittings must be welded stress-free.

4. Fusion process

- 4.1 Position the fitting with even air gap around the circumference.
- 4.2 Regulate fusion equipment for the right fusion parameter.
- 4.3 Compare the indications of the fusion equipment with the parameters of the label.
- 4.4 Start and watch the fusion process.

Do not move or stress pipe and fitting during the whole fusion process and cooling time.

5. Cooling time and pressure test

A fused pipe-joint shall not be moved (no release of the fixation) or stressed before complete cooling.

The minimum required cooling time is marked on each aquatherm electrofusion socket. Ambient temperatures of more than 25 °C or strong sun-radiation need longer cooling times.

Working pressure

The operation pressure can be taken from the imprint on the electric welding socket. The relation between working temperature, pressure load and service life is given in the tables "Permissible working pressure."

For further information concerning electrofusion socket and details about the aquatherm electrofusion device read the enclosed operating instructions.

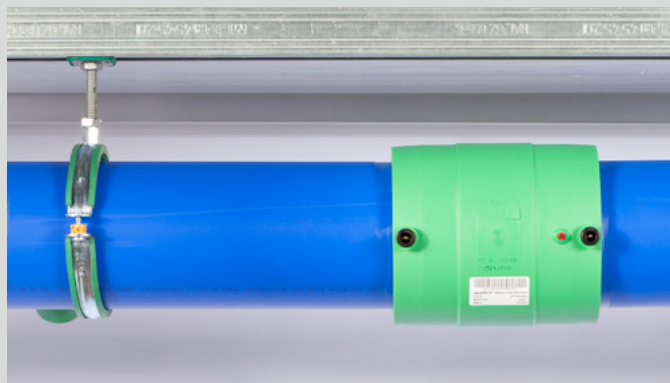

Push the second pipe – also peeled and cleaned – into the socket

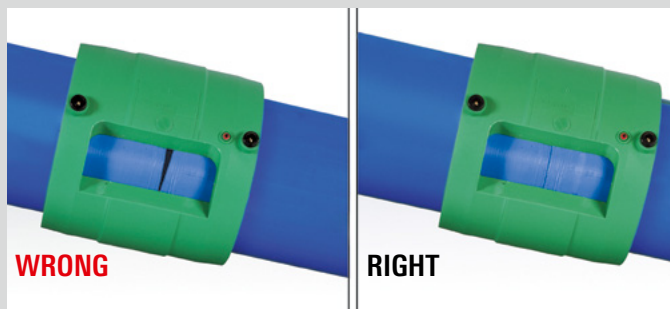

For a stable welding result it is important that both pipe ends inside the electrofusion socket are with parallel faces! Follow the minimum welding depth – absolutely!

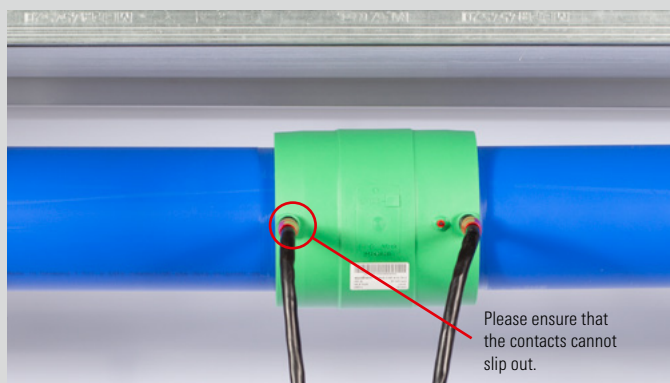

Adjust the socket diameter on the welding device. Start and control welding process. Keep the cooling time. Finished!

Kind of stress	Compressive stress	Minimum waiting period
Tension, bend, torsion of unpressurized pipes		20 minutes
Test- or working pressure of pipes pressurized	up to 0.1 bar (1.5 psi)	20 minutes
	0.1 up to 1 bar (1.5–14.5 psi)	60 minutes
	over 1 bar (14.5 psi)	120 minutes
Repeating of the welding process		60 minutes

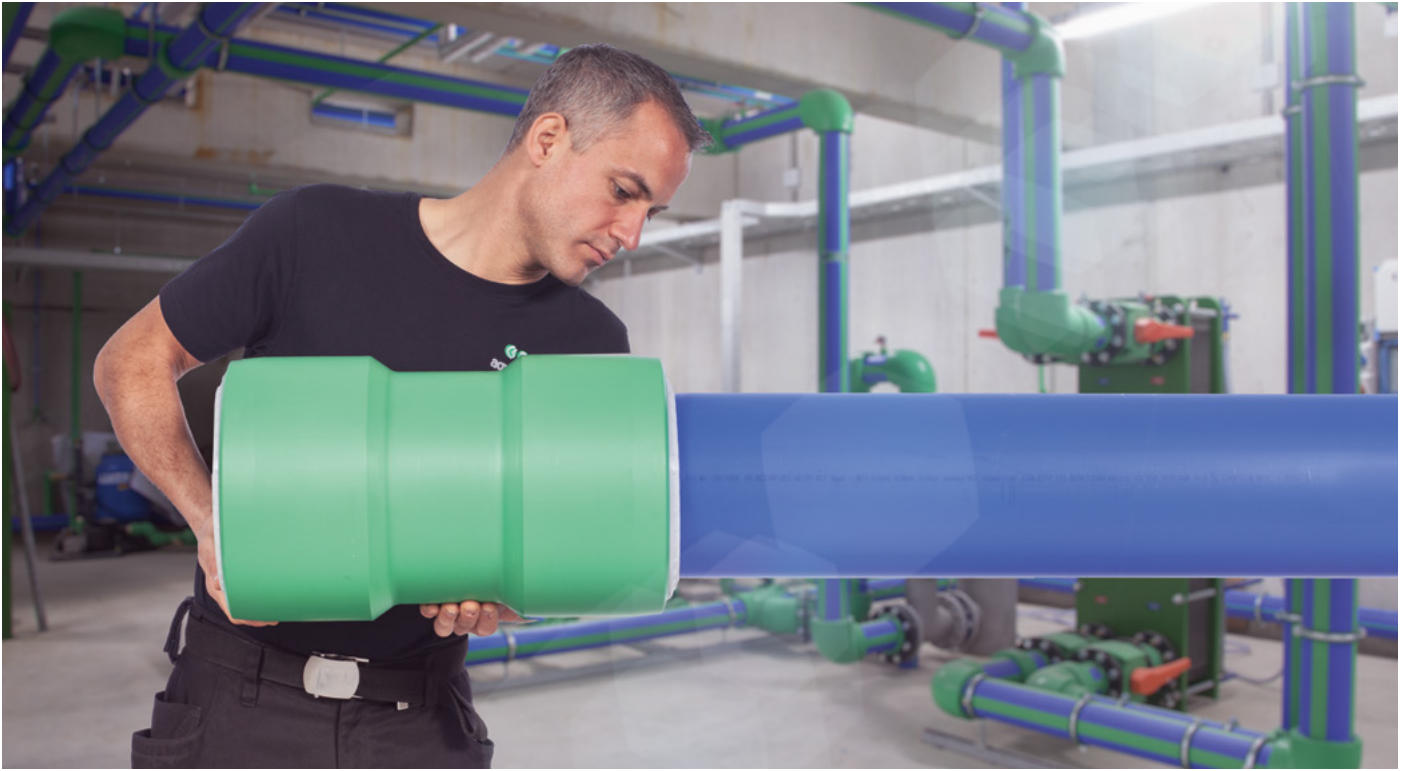

**QUICK CONNECTIONS IN MINUTES,
FOR LIFETIME SECURITY**

Leak-free joints in just a few minutes: This is what the new aquatherm push-fit fittings offer. They provide a simple, fast and at the same time secure connection for aquatherm blue pipes in heating, cooling and industrial applications.

Thanks to the simple push-fit system, aquatherm piping systems can be connected up to 40% faster than with electrofusion socket welding. The tool requirement is also significantly lower. Joint assembly can be done in any weather conditions, in tight spaces such as shafts for risers or in trenches, and even under the ceiling.

Made from the high-quality and robust material fusiolen® PP-RCT, the aquatherm push-fit fitting is suitable for fluid temperatures between 0 °C and 95 °C (32-203°F). This is confirmed by the test institute IMA Dresden, Germany.

The product portfolio ranges from push-fit adapters and push-fit couplings to moulded and fabricated fittings in various configurations and sizes. aquatherm thus offers all components for piping installation in plant engineering. The piping system is not only corrosion-free but can be subjected to full pressure immediately after installation without any waiting times.

ADVANTAGES

- increased pressure and temperature resistance through fusiolen® PP-RCT
- secure connection
- profile sealing gasket protects the mechanics of the push-fit fittings from dirt, debris and contaminants
- corrosion-free
- long life span
- full bore flow, no reduction in diameter
- can be used with standard and UV aquatherm blue pipe products in SDR 11 and SDR 17.6, for sizes 90 mm (3-in) to 450 mm (18-in)



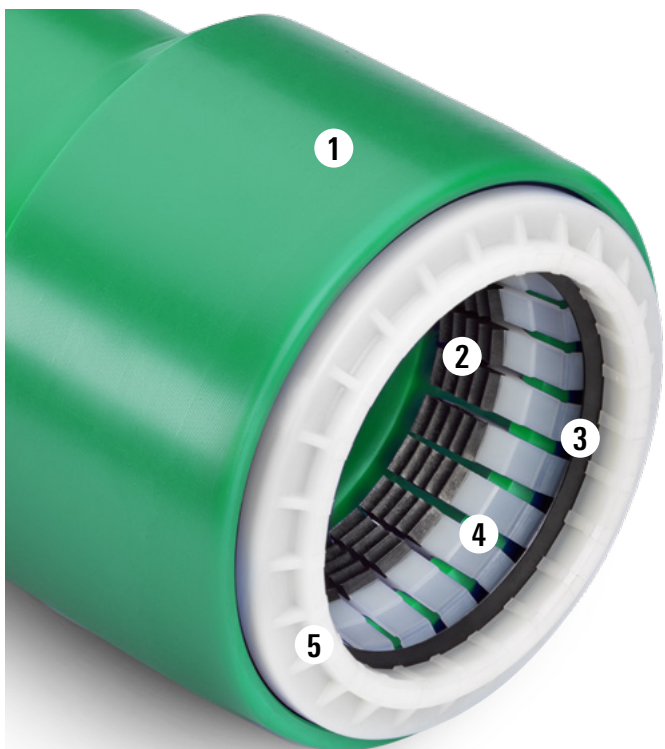

- 1 Body of socket**
extremely rugged and made of the durable fusiolen® PP-RCT material
- 2 Grip elements made of high-strength engineered thermoplastic**
for extra tensile strength
- 3 Profile gasket**
prevents the penetration of dirt, debris and contaminants
- 4 Spring-loaded elements**
lead the grip elements and create the required radial forces
- 5 Thrust protection unit**
can be easily replaced if necessary

INSTALLATION ADVANTAGES

- fast installation times
- can be done in all weather conditions, even at temperatures below 0 °C or when raining or snowing
- assembly in confined spaces such as shafts for risers or trench laying
- no heavy or expensive tools necessary
- residual fluid in the pipes is not a problem when installing in existing systems
- leakproof connection immediately, no wait time

30 MINUTES OR 6 MINUTES?

NO COOLING OR WAIT TIME FOR PUSH-FIT CONNECTIONS!

Electrofusion joint completed:
30 minutes/piece

aquatherm push-fit fittings assembled:
6 minutes/piece

ASSEMBLY INSTRUCTIONS SUMMARY

Note: The following steps are a summary of the assembly procedure. Please consult the full assembly instructions provided with the fittings for proper installation. Or send an email to infoservice@aquatherm.de to receive the PDF.

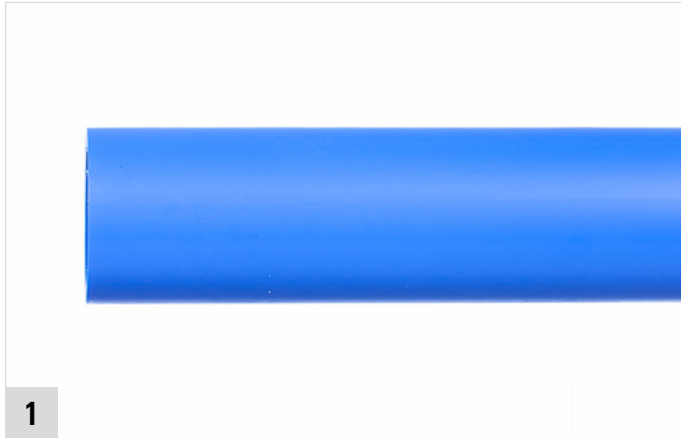

1

Cut the pipe ends to length at a right angle.



2

Chamfer the pipe end with the aquatherm chamfering tool (see table minimum chamfer length).



3

Read insertion depth on the push-fit fitting ...



4

... and mark the insertion depth on the pipe.



5

Apply lubricant evenly on the pipe (5 cm or 2-1/2 in.).



6

Apply lubricant also on the rubber gaskets of the push-fit fitting.

WARNING: SHARP EDGES!

The grip ring on the interior of the fitting contains sharp components. Hand protection and proper tools must be used when applying lubricant to the interior of the fitting or reaching inside the fitting for any other purpose.

Note: When processing pipe dimensions ≤ 160 mm, no pulling/alignment device is required. However, proper alignment must be maintained in all sizes when assembling.



7 Place the push-fit fitting on the pipe end and press it over the first rubber seal.



8 Final insertion of the pipe into the fitting must be done with an alignment tool.



9 Attach the alignment tool securely to the pipe and the push-fit fitting.



10 Pull the push-fit fitting onto the pipe end up to the marked insertion depth.

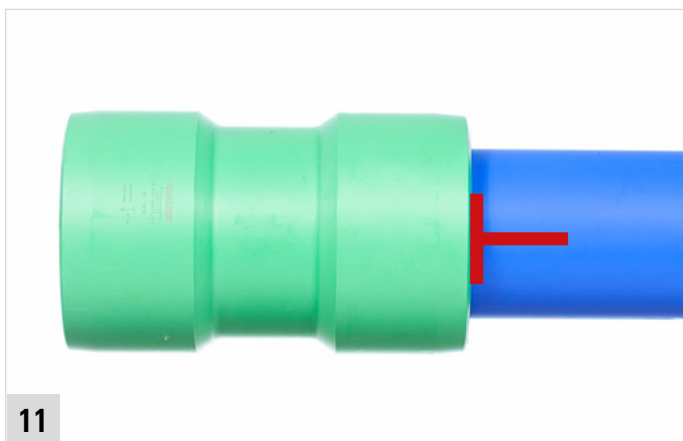

11 Completed assembly showing proper alignment and insertion.

TOOLS	
Art.-no.	Description
9800050541	ratchet puller (come-along)
9800050510	chamfering tool 32 – 250 mm
9800050533	Tension band width 50 mm including drawbar eyes
9800050534	brush
9800050535	lubricant
9800050536	Pipe clamp Ø250mm
9800050537	Pipe clamp Ø315mm
9800050538	Pipe clamp Ø355mm
9800050539	Pipe clamp Ø400mm
9800050540	Pipe clamp Ø450mm

MINIMUM CHAMFER LENGTH	
Outer diameter [mm]	Chamfer length [mm]
90	10
110	
125	
160	
200	15
250	20
315	
355	
400	
450	

MINIMUM CHAMFER LENGTH	
Nominal size [inch]	Chamfer length [inch]
3	3/8
3-1/2	
4	
6	5/8
8	
10	
12	
14	
16	7/8
18	

FLANGE CONNECTIONS

THE FOLLOWING MUST BE OBSERVED IN THE USE OF FLANGE CONNECTIONS:

Flange adapter respectively the sealing surfaces must always be aligned parallel to each other. A subsequent tightening of the flange connection after the welding process must be avoided. It is important to ensure that the flange faces are clean and undamaged.

The screw length should be selected so that the screw thread is as flush as possible, maximum two threads from the nut. To distribute the force of the screw head and the nut over a larger area, washers are used. Screws, nuts and washers must be clean and undamaged.

In order to achieve proper force distribution (surface pressure) acting on the seal, note the following:

- Screw joints must be tightened diagonally and evenly
- Torque information on the individual flanges according to DVS 2210-1 supplement 3 must be followed (see table). For valve or device connections, the manufacturer's instructions must be observed.

For flange connections, exposed to a mutual load, take care that they are checked as part of the maintenance and retightened, if necessary.

TORQUE FLANGE according to manufacturer's instructions

Art. no.	Dimension	DN specification	Nm
1040032130	32 mm	25	15
1040040131	40 mm	32	20
1040050132	50 mm	40	30
1040063133	63 mm	50	35
1040075134	75 mm	65	40
1040090135	90 mm	80	40
1040110136	110 mm	ohne	50
1040125137	125 mm	100	50
1040160138	160 mm	125	60
1040200139	200 mm	150	75
1040250140	250 mm	200	95
1040315141	315 mm	250	100
1040355142	355 mm	300	100
1040400143	400 mm	350	100
1040450144	450 mm	400	120
1040500145	500 mm	450	190
1040630146	630 mm	500	220

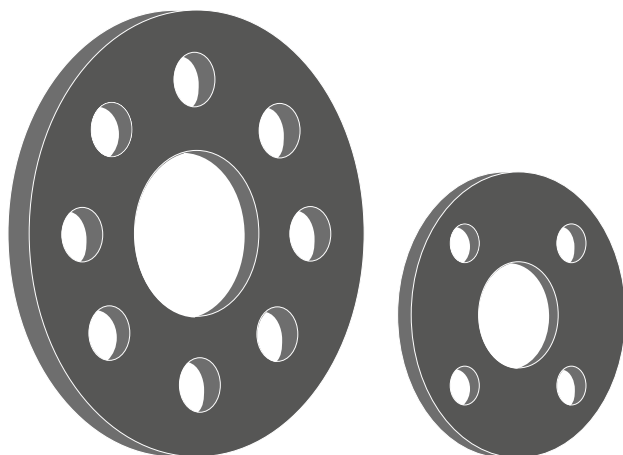

TIGHTENING SEQUENCE

Number of screws	Criss-Cross Pattern Tightening Sequence
4	1 - 3 - 2 - 4
8	1 - 5 - 3 - 7 - 2 - 6 - 4 - 8
12	1 - 7 - 4 - 10 - 2 - 8 - 5 - 11 - 3 - 9 - 6 - 12
16	1 - 9 - 5 - 13 - 3 - 11 - 7 - 15 - 2 - 10 - 6 - 14 - 4 - 12 - 8 - 16
20	1 - 11 - 6 - 16 - 3 - 13 - 8 - 18 - 5 - 15 - 10 - 20 - 4 - 14 - 9 - 19 - 7 - 17 - 2 - 12

Following the table, tighten the given screw number to the desired torque value for the given round of tightening.

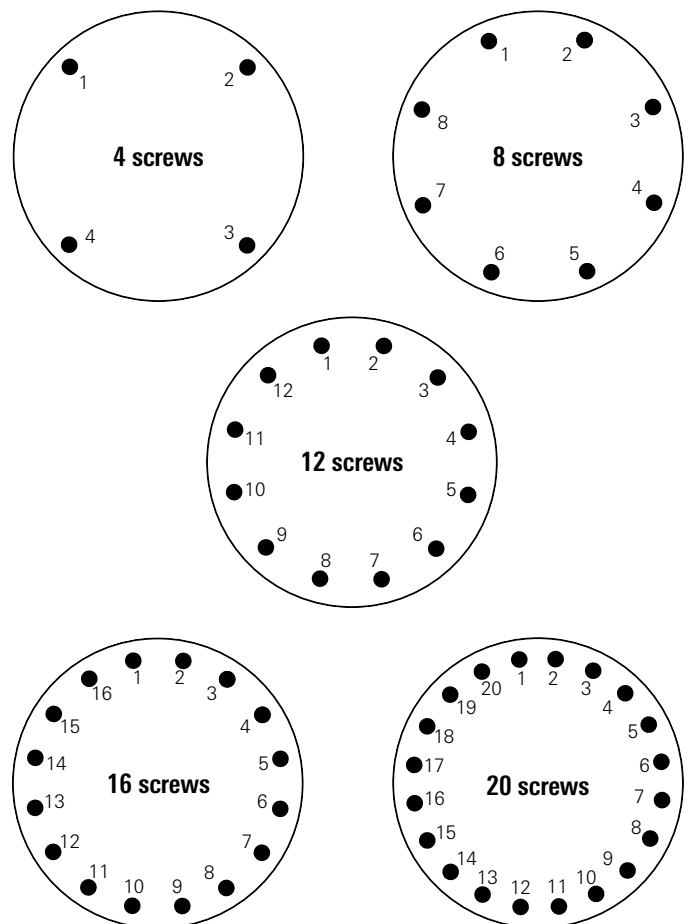

REPAIR OPTIONS

Pipe repairs with the aquatherm green pipe electrofusion socket

Cut squarely 3 to 4 lengths of a fitting out of the defect pipe, symmetrically to the defect. Fit the new pipe into this gap. Prepare the pipe ends of the existing pipe as in the case of a new welding.

Peel the new piece of pipe on both sides with the peeling tool on a length of more than the length of one fitting.

Unwrap two fittings and carefully move the fittings over both ends of the new pipe.

Then place the repair-pipe into the gap and move the fittings until they are aligned with the markings on the existing pipes.

Take care, that the fittings are exactly aligned and completely free of stress before welding.

Additional possibilities of repair

Damaged pipes may be repaired by means of

fusion (see Part B)
electrofusion socket (see Part F).

In addition to this the aquatherm PP-R/PP-RP systems offers the possibility of the

pipe repair stick.

The required welding tool (Art. no. 9800050307 / 9800050311) and repair stick (Art. no. 1090000035) are described on page 175.

The installation information is enclosed with the welding tool, but may also be ordered separately (Order-No. D 11450) from aquatherm.

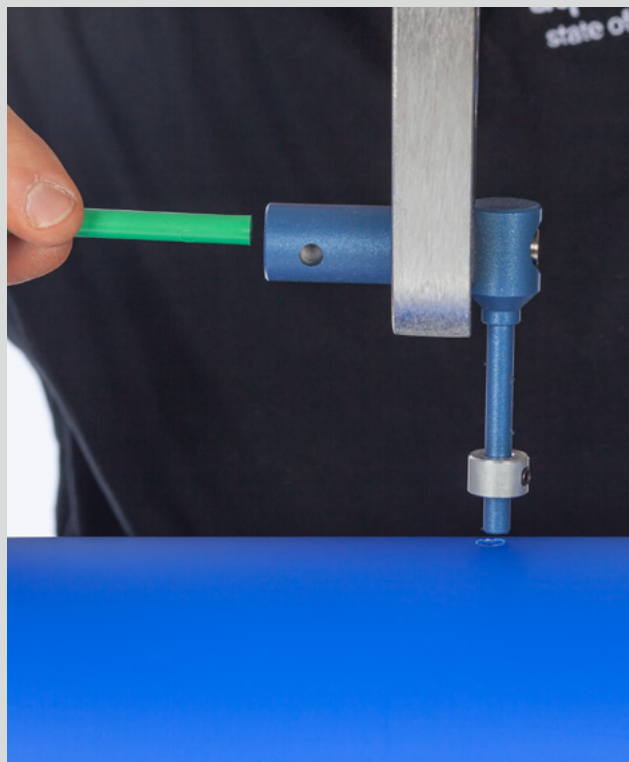

Heat-up



Repair stick



Cutting

PART G: BUTT-WELDING OF PIPE DIMENSION 160–630 MM

The following aquatherm pipes series are available:

aquatherm blue pipe SDR 11 MF fibre composite pipe

aquatherm blue pipe SDR 11 MF OT fibre composite pipe

aquatherm blue pipe SDR 17,6 MF fibre composite pipe

Pipes and fittings are fused, as explained below, by butt welding:

1. Protect your place of work from weather influences
2. Check, if welding machine works properly and heat it up
3. Cut pipes into required length
4. Plastic pipes are aligned and fixed by means of the clamping elements
5. Use the milling machine for planing the pipe end to be plane-parallel
6. Remove the debris and clean the pipe ends with methylated spirit
7. Check if pipes match (tolerance: max. 0.1 x wall thickness)
8. Check width of gap between the two pipes to be welded (tolerance: max. 0.5 mm)
9. Check the temperature of the heating element (210 °C +/- 10 °C)
10. Clean the heating element

IMPORTANT:

Before welding, the side to be welded of the aquatherm blue pipe ot must be chamfered with the aquatherm chamfering tool.

To ensure an optimal weld joint, the heating plates' surfaces have to be cleaned before each welding process and be free of visible and invisible residues.

Before welding, pipes are cut into the required lengths

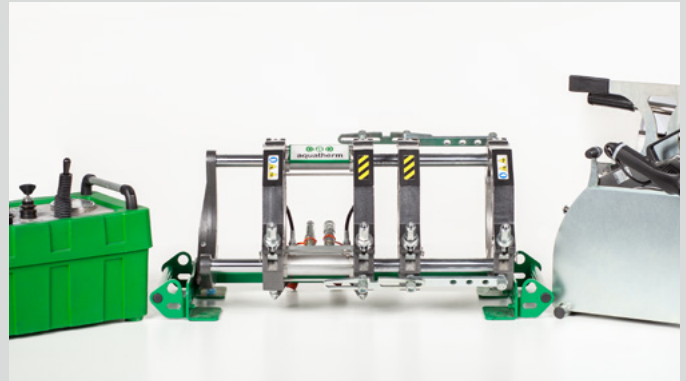

Check performance of the welding machine and heat it up

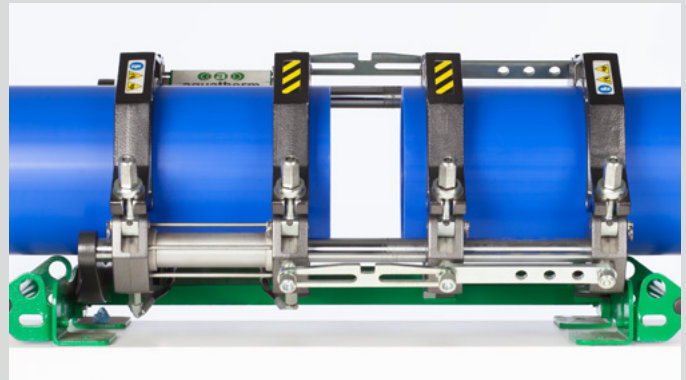

The parts to be welded are fixed and aligned respectively, the milling machine is used

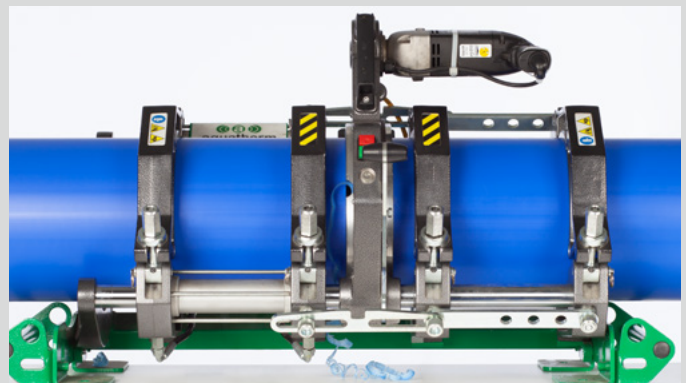

Chamfering of the front side in case of the OT and UV pipe

PART G: BUTT-WELDING OF PIPE DIMENSION 160–630 MM

11. After the heating element has been positioned, the pipes are pushed onto the heating plate with a defined adjusting pressure.
12. After reaching the specified bead height (see tablet) the pressure is reduced. This process marks the beginning of the heating time. This time is for heating up the pipe ends up to the right welding temperature.

Specified bead height in mm:

	SDR 11	SDR 17,6
160 mm	1,0	1,0
200 mm	1,0	1,0
250 mm	1,5	1,0
315 mm	2,0	1,0
355 mm	2,0	1,5
400 mm	2,0	1,5
450 mm	2,5	1,5
500 mm		2,0
630 mm		2,0

13. When heating time has expired, divide the machine slide, remove heating element quickly and join the pipes (by putting both parts of the slide together).
14. The pipes are fused with the required welding pressure and cooled down under pressure.
15. The welded connection can be unclamped – the welding process is finished.

Additionally please follow the instructions given in the operating manual of the welding machine and observe guideline DVS 2207, part 11.

Important Note

1. The welding machines have to be suitable for the welding of pipes with a diameter/wall thickness ratio of up to SDR 7.4

aquatherm recommends the following manufacturers of welding machines for butt welding:

Company Ritmo
Company Widos

2. For hydraulically operated welding machines, the real manometer pressure has to be calculated in consideration of the hydraulic piston area.

This value can be taken from the respective operating manuals.

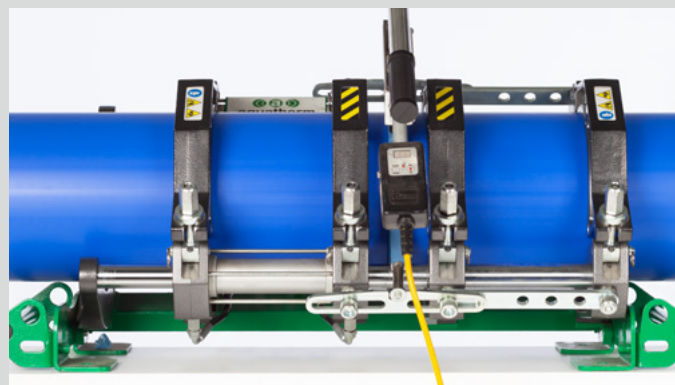

Positioning of heating element

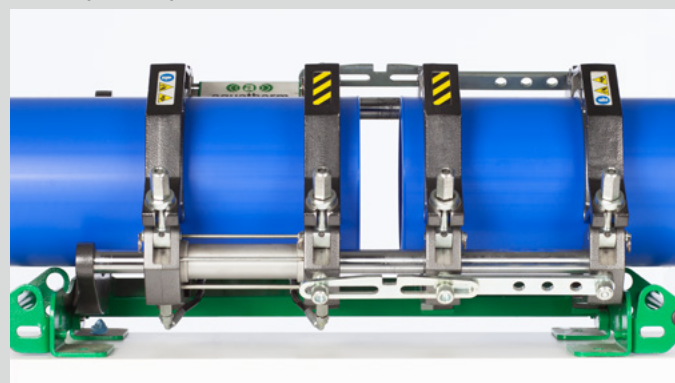

Divide the machine slide, remove heating element

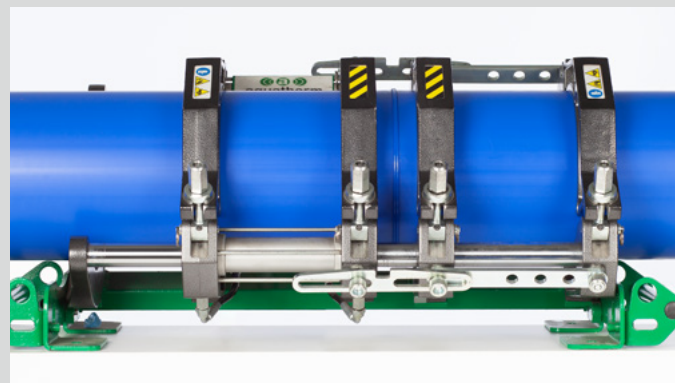

Join the pipes, cool under pressure.

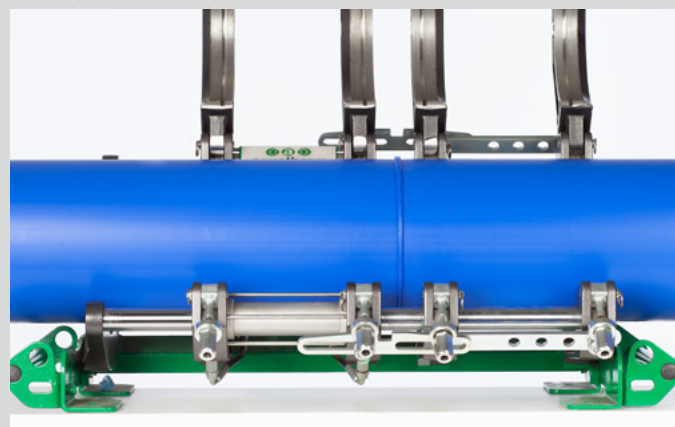

Unclamp and work on...

Visual inspection of fusion seam – Misalignment and gap width for butt welding

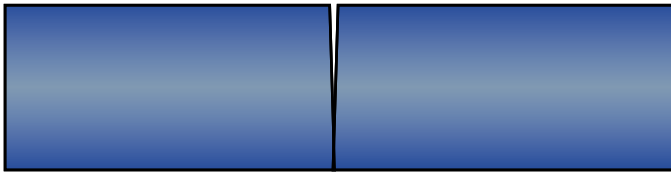

Gap width up to 355 mm outer diameter = 0.5 mm
 Gap width from 400 mm to 630 mm outer diameter = 1 mm

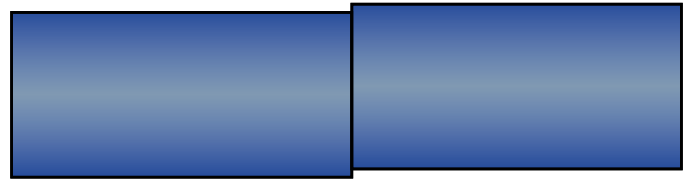

The misalignment cannot be more than 10 % of the wall thickness or max. 2 mm

Welding defects during butt-welding

Normally a bead around the entire circumference is formed at the edge of the socket during the welding process. This bead indicates the proper welding. It is important to assure that the following welding defects are avoided:

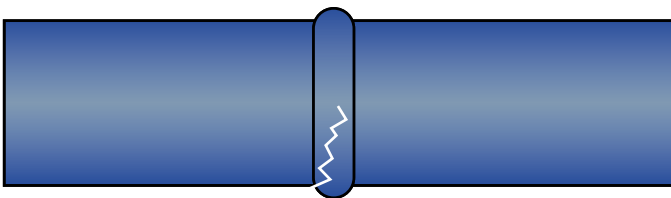

Cracks

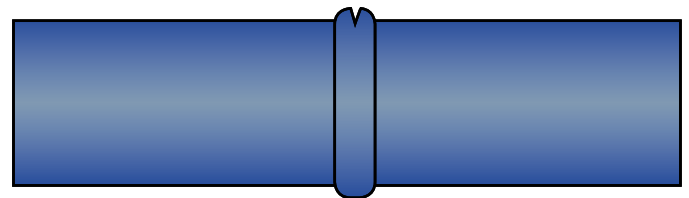

Grooves in the bead

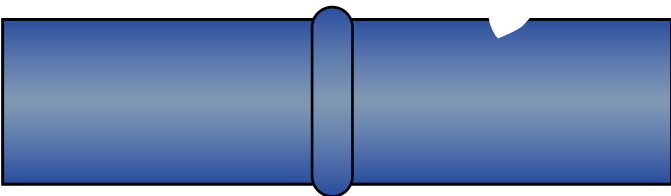

Grooves and scratches

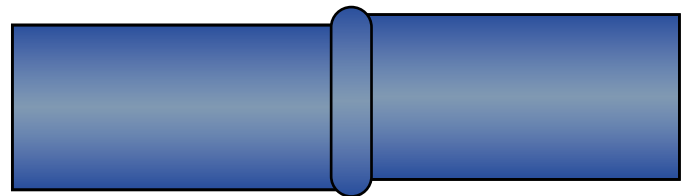

Misalignment of the joining area

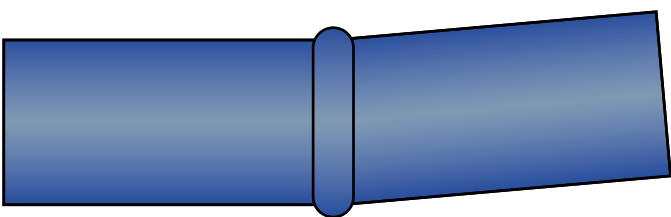

Tilting of the joining area

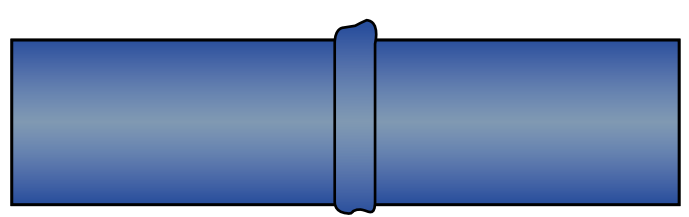

Uneven welding bead

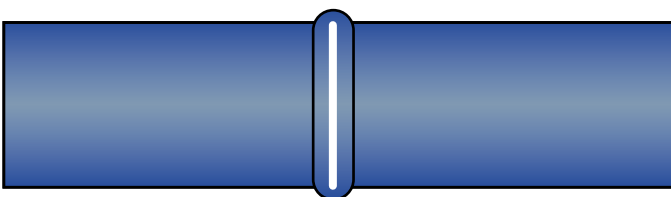

Lack of fusion at the joining area

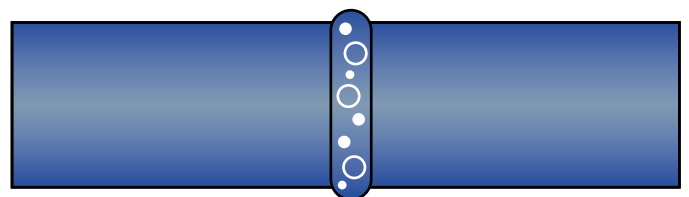

Pores, voids and inclusion of impurities

Correct butt welded seam

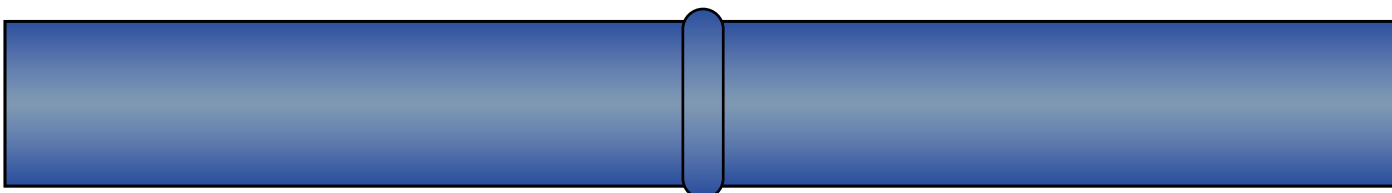
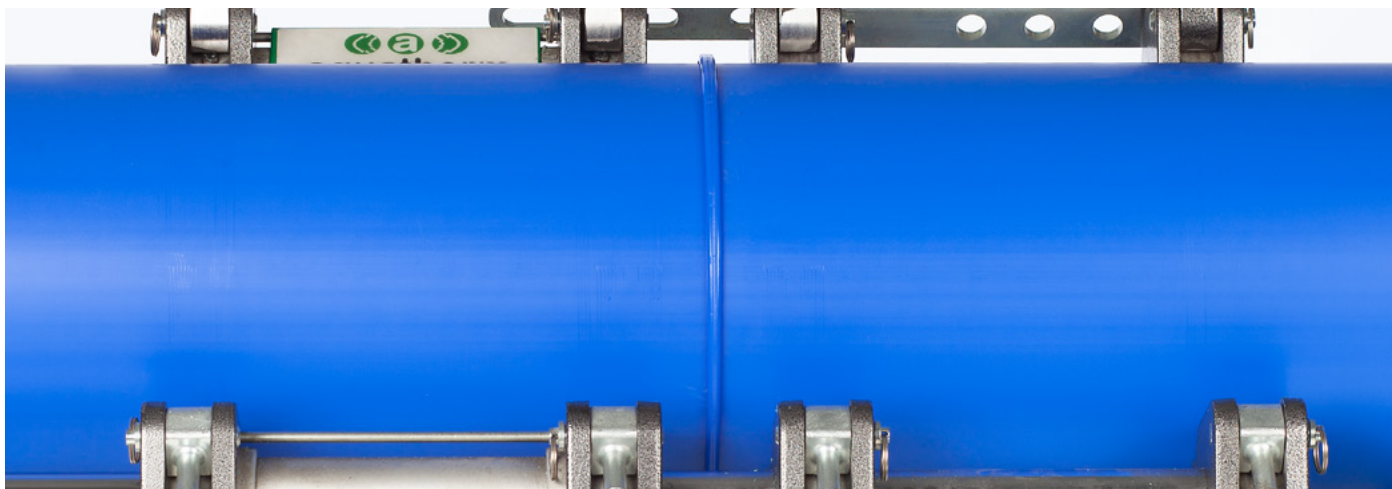

The visual inspection may be only a first indication of the welding seam quality.
It is not a replacement for the leak test, which has to be carried out after the completion of the installation.

Requirements for welding



The immediate welding area is to be protected against bad climatic conditions (e.g. wind, moisture and low temperatures).



If the pipes are heated unevenly as a result of sun exposure, a temperature compensation will have to be provided by covering the welding area from time to time. Cooling down by draft during the welding process should be avoided.



For perfect welding joints, both the welding areas and tools must be clean and free of grease.

FASTENING TECHNIQUE / FIXED POINTS / SLIDING POINTS

Fastening technique

Pipe clamps for aquatherm pipes must be dimensioned for the external diameter of the plastic pipe.

Take care that the fastening material does not mechanically damage the surface of the pipe (aquatherm pipe clamps Art. no.: 9600060516 – 9600060660).

All pipes should be fastened with only aquatherm’s green rubber compound fasteners, with expansion spacers, or other as deemed equal or approved by aquatherm and /or the project’s Hydraulic Consultant.

Basically it must be distinguished on pipe assembly, whether the fastening material is used as

- a fixed point or
- a sliding point.

Fixed points

On locating fixed points the pipelines are divided into individual sections. This avoids uncontrolled movements of the pipe.

In principle fixed points have to be measured and installed in a way, that the forces of expansion of aquatherm pipes as well as probable additional loads are accommodated.

On using threaded rods or threaded screws the drop from the ceiling should be as short as possible. Swinging clamps should not be used as fixed points.

Basically vertical distributions can be installed. Risers do not require expansion loops, provided that fixed points are located immediately before or after a branch.

To compensate the forces arising from the linear expansion of the pipe there must be sufficient and stable clamps and mountings.

aquatherm pipe clamps meet all mentioned requirements and – when considering the following installation instructions – are perfect for fixed point installations.

Sliding points

Sliding clamps have to allow axial pipe movements without damaging the pipe.

On locating a sliding clamp it has to be ensured that movements of the pipelines are not hindered by fittings or armatures installed next to the clamps.

aquatherm pipe clamps have an extra even and sliding surface of the sound insulation insert.

INSTALLATION ADVICE / LINEAR EXPANSION / CONCEALED INSTALLATION

Installation advices

aquatherm pipe clamps are perfectly suited for fixed point and sliding point installations.

The application of distance rings depends on the type of pipe.

Fastening	MF Pipes (fibre composite pipe) & S Pipes (single layer)
Sliding Point	1 distance ring
Fixed point	no distance ring

Linear expansion

The linear expansion of pipes depends on the difference of operating temperature to installation temperature:

$$\Delta T = T_{\text{operating temperature}} - T_{\text{installation temperature}}$$

Therefore cold water pipes have practically no linear expansion.

Because of the heat dependent expansion of the material, the linear expansion must especially be considered in case of hot and heating installations. This requires a distinction of the types of installation, e.g.

- **Concealed installation**
- **Installation in ducts**
- **Open installation.**

Concealed installation

Concealed installations generally do not require a consideration of the expansion of aquatherm pipes.

The insulation according to DIN 1988 or the EnEV (energy saving regulation) provides enough expansion space for the pipe. In the case where the expansion is greater than the room to move in the insulation, the material absorbs any stress arising from a residual expansion.

The same applies to pipes, which do not have to be insulated according to current regulations.

A temperature induced linear expansion is prevented by the embedding in the floor, concrete or plaster. The compressive strain and tensile stress arising from this are not critical as they are absorbed by the material itself.

INSTALLATION IN DUCTS

Installation in ducts

Due to the different linear expansion of the aquatherm pipes with or without stabilization, the installation of pipe branches in risers has to be made according to the selected type of pipe.

aquatherm blue pipe MF

The linear expansion of aquatherm fibre composite pipes in vertical risers can be ignored.

The positioning of a fixed point directly before each branch-off point is sufficient. All clamps in the riser must be installed as fixed points (see 1).

In general it is possible to install risers rigidly, that means without expansion joints. This directs the expansion on the distance between the fixed points, where it is ineffective.

For a maximum distance between two fixed points please refer pages 76/77.

The installation of risers of aquatherm pipes without stabilizing components (fibre) requires a branch pipe, which is elastic enough to take the linear expansion of the riser.

This can be ensured by a favourable fixing of the riser in the duct (see 2).

An adequate large pipe liner also gives sufficient elasticity to the branch-off pipe (see 3).

Furthermore the installation of a spring leg gives the appropriate elasticity (see 4).

When laying aquatherm pipes through the wall and ceiling, the fire protection must be observed (see pages 26-28).



Positioning of the fixed point clamp

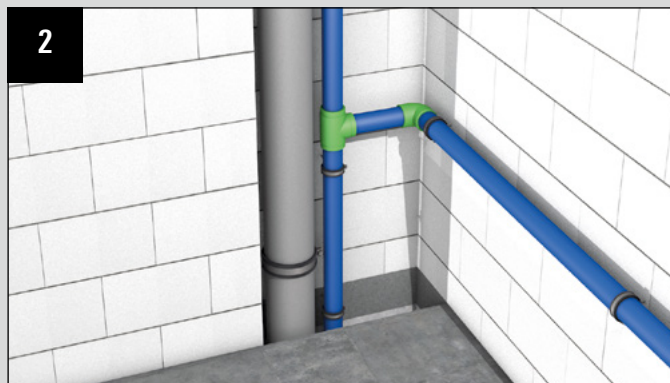

Favourable fixing



Large diameter pipe liner



Installation of a spring leg

OPEN INSTALLATION / CALCULATION OF THE LINEAR EXPANSION

Open installation

In case of open installed pipes (e.g. in the basement), excellent optical characteristics and form stability are important. aquatherm pipes for cold water and aquatherm fibre composite pipes for hot water and heating plants make this possible. The coefficient (α) of linear expansion of aquatherm composite pipes is only

$$\alpha_{\text{green/blue pipe MF}} = 0.035 \text{ mm/mK}$$

and therefore nearly identical to the linear expansion of metal pipes.

The coefficient of linear expansion of aquatherm pipes without stabilizing components is

$$\alpha_{\text{green/blue pipe}} = 0.150 \text{ mm/mK}$$

aquatherm fibre composite pipes must have enough space to expand (see page 68 and 69). An expansion control must be required for long and straight fibre composite pipes (over 40 m).

aquatherm pipes without the stabilizing compound should have the expansion control after 10 m straight pipelines. Risers of composite pipes may be installed rigidly without expansion compensation. The following formula, calculation examples, data-tables and diagrams help to determine the linear expansion. The difference between working temperature and maximum or minimum installation temperature is essential for the calculation of linear expansion.

Calculation of the linear expansion

Given and required values

Symbol	Meaning	Value	Measuring unit
ΔL	Linear expansion	?	[mm]
α 2	Coefficient of linear expansion aquatherm fibre composite pipe	0,035	mm/mK
α 3	Linear expansion coefficient	0,15	mm/mK
L	Pipe length	25,0	[m]
T _B	Working temperature	60	°C
T _M	Installation temperature	20	°C
ΔT	Temperature difference between working and installation temperature (ΔT = T _w - T _M)	40	K

The linear expansion ΔL is calculated according to the following formula:

$$\Delta L = \alpha \times L \times \Delta T$$

Material:

aquatherm MF-fibre composite pipe (α = 0.03 mm/mK)

$$\Delta L = 0.035 \text{ mm/mK} \times 25.0 \text{ m} \times 40 \text{ K}$$

$$\Delta L = 35.0 \text{ mm}$$

Linear expansion comparison: fibre composite to standard PP pipe

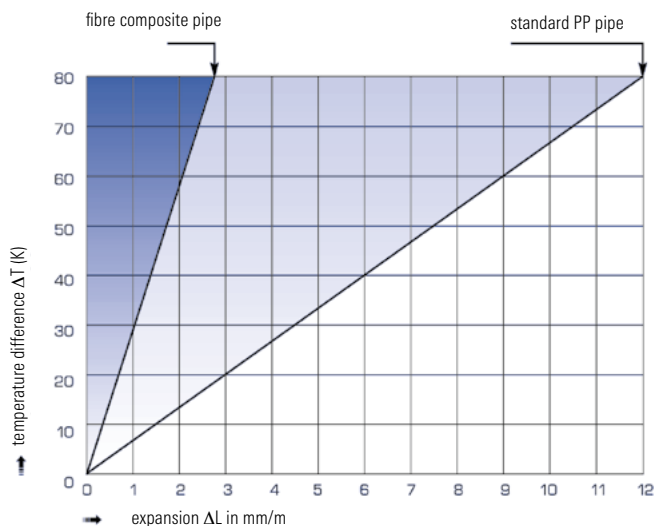

LINEAR EXPANSION

aquatherm blue pipe

(without fibre layer)

The linear expansion, described on the preceding pages, can be taken from the following tables and graphs.

Linear expansion ΔL in [mm]: aquatherm blue pipe - $\alpha = 0.150$ mm/mK

Pipe length	Difference in temperature $\Delta T = T_{\text{operating temperature}} - T_{\text{installation temperature}}$							
	10 K	20 K	30 K	40 K	50 K	60 K	70 K	80 K
	Linear expansion ΔL (mm)							
5 m	8	15	23	30	38	45	53	60
10 m	15	30	45	60	75	90	105	120
15 m	23	45	68	90	113	135	158	180
20 m	30	60	90	120	150	180	210	240
25 m	38	75	113	150	188	225	263	300
30 m	45	90	135	180	225	270	315	360
35 m	53	105	158	210	263	315	368	420
40 m	60	120	180	240	300	360	420	480
45 m	68	135	203	270	338	405	473	540
50 m	75	150	225	300	375	450	525	600

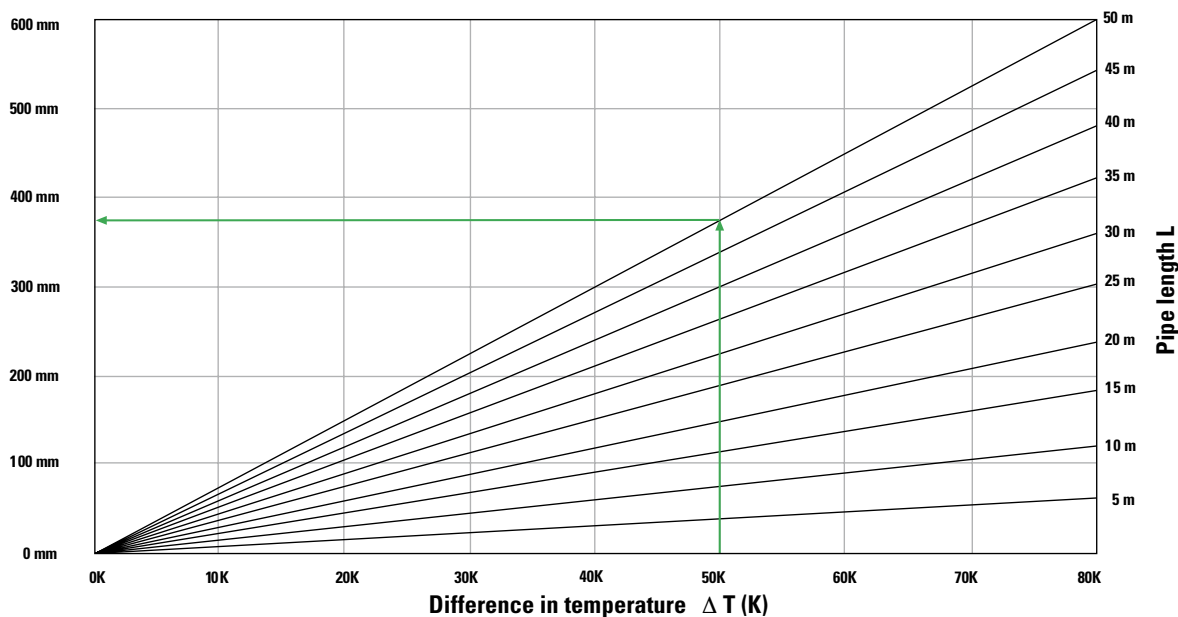

LINEAR EXPANSION

aquatherm blue pipe MF (fibre composite pipe)

Due to the integration and positive bond of the different materials, the aquatherm fibre composite pipes offer much higher stability. The linear expansion reduces its value to $\frac{1}{5}$ of the mere PP pipes.

Linear expansion ΔL in [mm]: aquatherm fibre composite pipes - $\alpha = 0.035 \text{ mm/mK}$

Pipe length	Difference in temperature $\Delta T = T_{\text{operating temperature}} - T_{\text{installation temperature}}$							
	10 K	20 K	30 K	40 K	50 K	60 K	70 K	80 K
	Linear expansion ΔL (mm)							
10 m	4	7	11	14	18	21	25	28
20 m	7	14	21	28	35	42	49	56
30 m	11	21	32	42	53	63	74	84
40 m	14	28	42	56	70	84	98	112
50 m	18	35	53	70	88	105	123	140
60 m	21	42	63	84	105	126	147	168
70 m	25	49	74	98	123	147	172	196
80 m	28	56	84	112	140	168	196	224
90 m	32	63	95	126	158	189	221	252
100 m	35	70	105	140	175	210	245	280

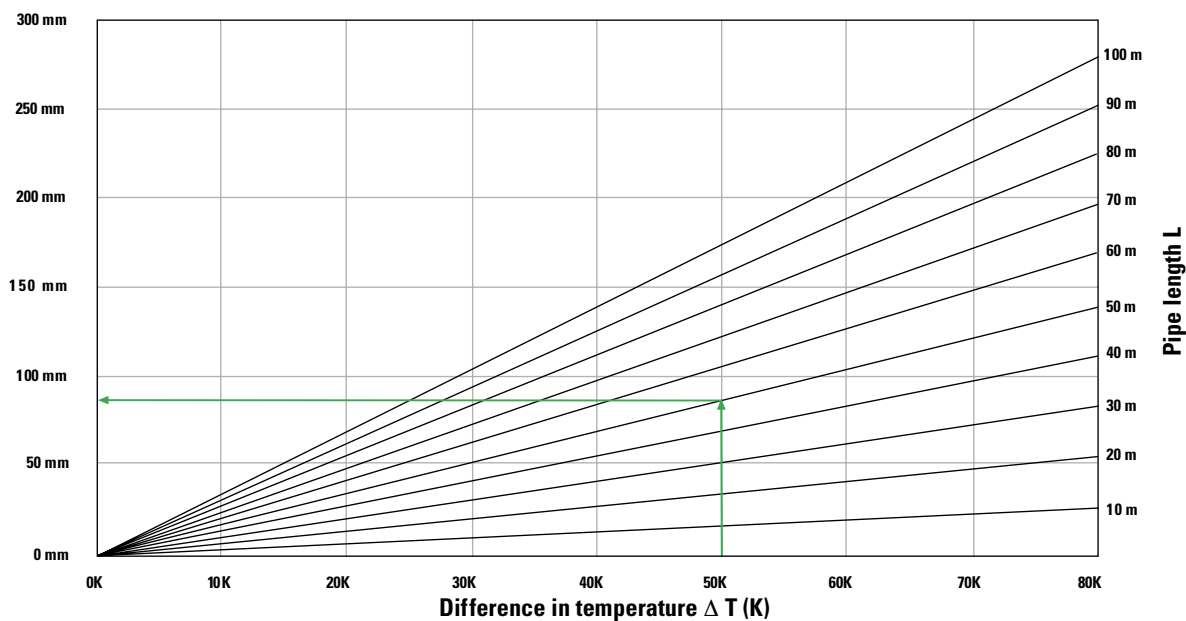

PIPE CLAMPS suitable as fixing point

aquatherm offers fixed-point fastenings for pipes from 160–630 mm (Art. no. 9600060768 – 9600060790). Packing unit is each with 1 piece.

Advantages:

- Reliable and permanent protection against perforation corrosion and breakdown of the static load capacity
- 1000 hours salt spray test without ferric oxide (rust)
- Suitable for installation in corrosive inner and outside areas
- Considerably higher corrosion protection than with electrogalvanized and hot-dip galvanized products (after spread test according to DIN EN ISO 9227)

Art. no.	diameter	min. torque clamp locking	min. torque height adjustment	height adjustment	fixing on building	measure „a”	weight per set
[-]	[mm]	[Nm]	[Nm]	[mm]	[-]	[mm]	[kg]
9600060768	160	25	75	192,5–283,5	M 12	354,1	8,55
9600060770	200	25	75	192,5–283,5	M 12	394,5	9,45
9600060774	250	50	75	192,5–283,5	M 12	444,8	19,37
9600060778	315	50	75	192,5–283,5	M 12	510	22,75
9600060780	355	50	75	192,5–283,5	M 12	550,1	24,84

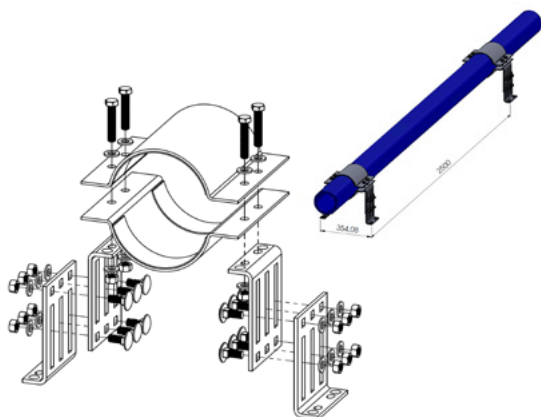

Art. no.	diameter	min. torque clamp locking	min. torque height adjustment	height adjustment	fixing on building	measure „a”	weight per set
[-]	[mm]	[Nm]	[Nm]	[mm]	[-]	[mm]	[kg]
9600060782	400	50	120	404,5 - 497,5	M16	823,2	43,64
9600060784	450	50	120	404,5 - 497,5	M16	873,3	46,25
9600060786	500	50	120	404,5 - 497,5	M16	923,4	48,87
9600060790	630	50	120	404,5 - 497,5	M16	1053,5	55,66

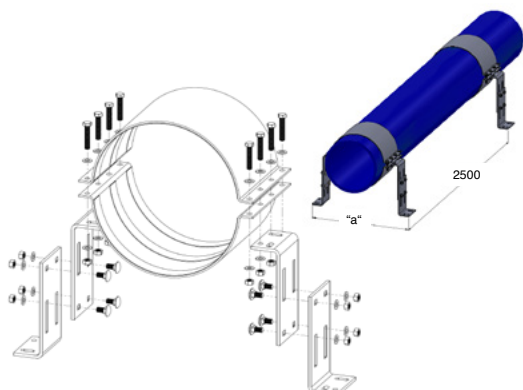

BENDING SIDE

Linear expansion due to temperature difference between operating temperature and installation temperature can be compensated by different installation techniques.

Bending side

In most cases direction changes can be used to compensate for linear expansion in pipes.

The values of the bending side can be taken directly from the tables and graphs on the following pages.

Symbol	Meaning	
L_{BS}	Length of the bending side	[mm]
K	Material specific constant	15,0
d	Outside diameter	[mm]
ΔL	Linear expansion	[mm]
L	Pipe Length	[m]
FP	Fixed point	
GP	Sliding point	

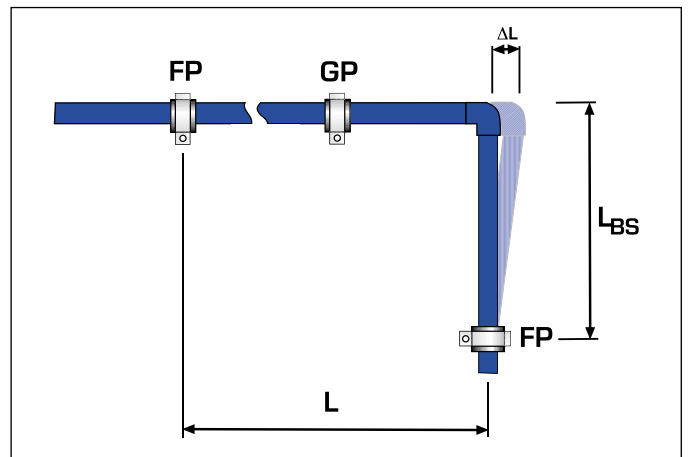

Calculational determination of the bending side length

$$L_{BS} = K \times \sqrt{d \times \Delta L}$$

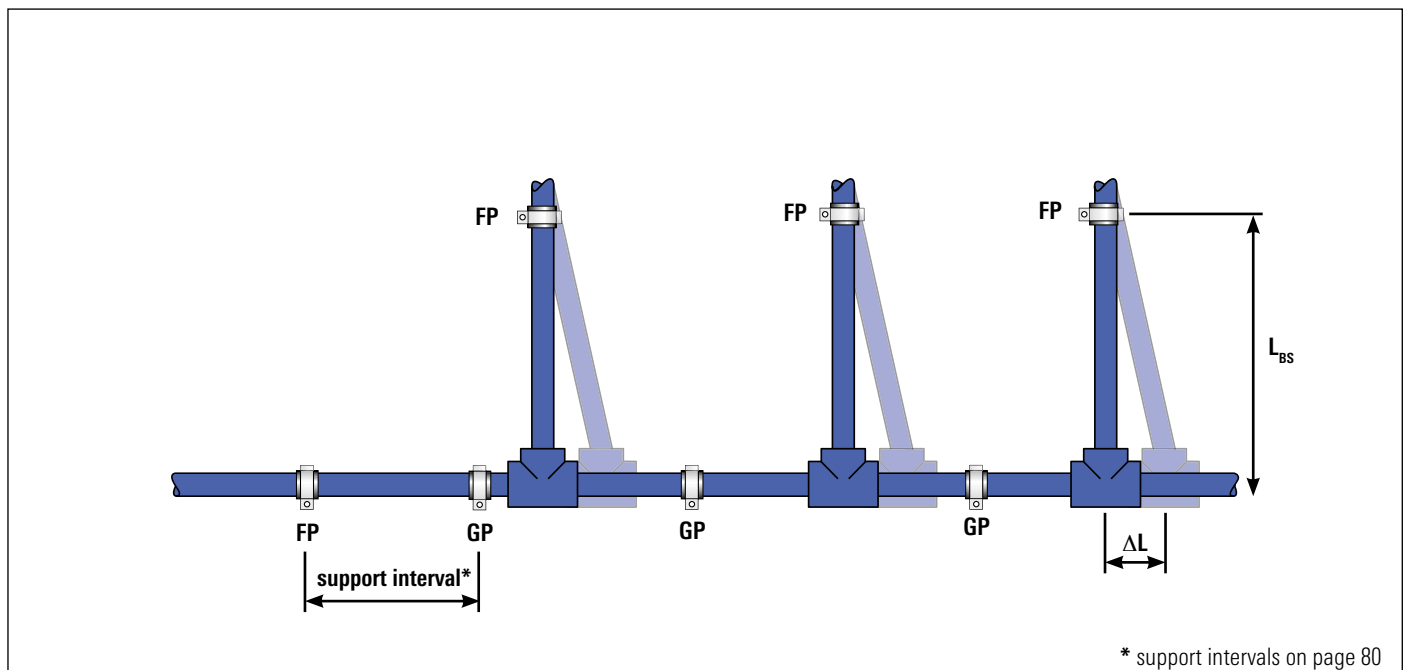

* support intervals on page 80

PRE-STRESS/BELLOW EXPANSION JOINT

Expansion loop

If the linear expansion cannot be compensated by a change in direction, it will be necessary to install an expansion loop with long and straight pipelines.

In addition to the length of the bending side L_{BS} the width of the pipe bend A_{min} must be considered.

Symbol	Meaning	
A_{min}	Width of the expansion loop	[mm]
SA	Safety distance	150 mm

The pipe bend A_{min} is calculated according to the following formula:

$$A_{min} = 2 \times \frac{\Delta L}{2} + SA$$

The width of the expansion loop A_{min} should be at least 210 mm.

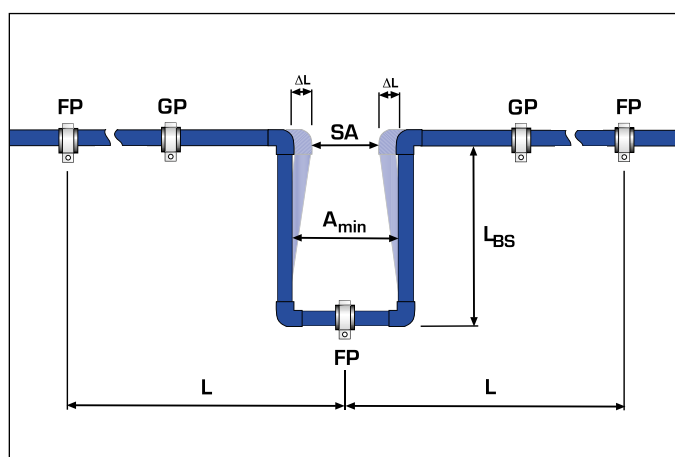

Determination size of expansion loop

Example

Specification: Pipeline, length 80 m (MF pipe)

Determined expansion: $112 \text{ mm} = (\Delta L = \frac{0,035 \text{ mm}}{\text{mK}} \times 80 \text{ m} \times 40 \text{ K})$

The expansion loop should be installed exactly in the center of the pipe.

Calculation:

Given: $\Delta L = 112 \text{ mm}$
 $SA = 150 \text{ mm}$

Formula:

$$A_{min} = 2 \times \frac{\Delta L}{2} + SA$$

$$A_{min} = 2 \times \frac{112 \text{ mm}}{2} + 150 \text{ mm}$$

$$A_{min} = 262 \text{ mm}$$

The width of the expansion loop should be 262 mm in this example.

Pre-stress

Where space is limited, it is possible to shorten the total width A_{min} as well as the length of the bending side L_{BSV} by pre-stressing.

Pre-stress installations, if planned and carried out carefully, offer an optically perfect installation, as the linear expansion is hardly visible.

Symbol	Meaning	
L_{BSV}	Length of pre-stress	[mm]

The side length of expansion loops with pre-stress is calculated according to the following example:

$$L_{BSV} = K \times \sqrt{d \times \Delta L}$$

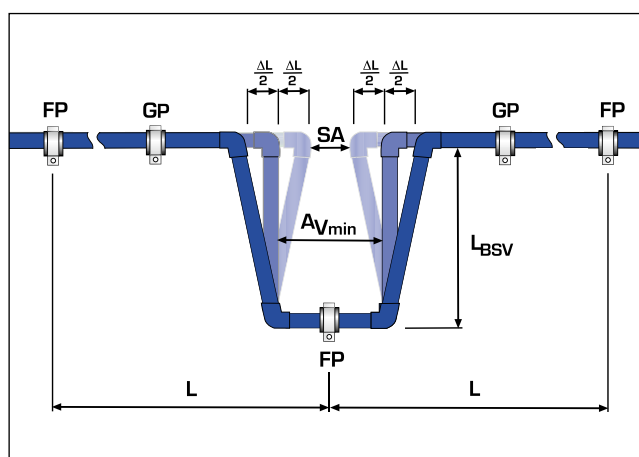

Bellow expansion joint

All bellow expansion joints for corrugated pipes designed for metal materials are unsuitable for aquatherm PP-R pipes.

When using axial expansion joints observe the manufacturer's instructions.

LENGTH OF BENDING SIDE

for aquatherm polypropylene pipes The length of the bending side with pre-stress L_{BSV} can be taken from the tables and graphs in consideration of the applied pipe dimensions and determined linear expansion.

Pipe Dimension	Linear expansion (mm)											
	10	20	30	40	50	60	70	80	90	100	110	120
	Length of bending side (m)											
20 mm	0,21	0,30	0,37	0,42	0,47	0,52	0,56	0,60	0,64	0,67	0,70	0,73
25 mm	0,24	0,34	0,41	0,47	0,53	0,58	0,63	0,67	0,71	0,75	0,79	0,82
32 mm	0,27	0,38	0,46	0,54	0,60	0,66	0,71	0,76	0,80	0,85	0,89	0,93
40 mm	0,30	0,42	0,52	0,60	0,67	0,73	0,79	0,85	0,90	0,95	0,99	1,04
50 mm	0,34	0,47	0,58	0,67	0,75	0,82	0,89	0,95	1,01	1,06	1,11	1,16
63 mm	0,38	0,53	0,65	0,75	0,84	0,92	1,00	1,06	1,13	1,19	1,25	1,30
75 mm	0,41	0,58	0,71	0,82	0,92	1,01	1,09	1,16	1,23	1,30	1,36	1,42
90 mm	0,45	0,64	0,78	0,90	1,01	1,10	1,19	1,27	1,35	1,42	1,49	1,56
110 mm	0,50	0,70	0,86	0,99	1,11	1,22	1,32	1,41	1,49	1,57	1,65	1,72
125 mm	0,53	0,75	0,92	1,06	1,19	1,30	1,40	1,50	1,59	1,68	1,76	1,84
160 mm	0,60	0,85	1,04	1,20	1,34	1,47	1,59	1,70	1,80	1,90	1,99	2,08
200 mm	0,67	0,95	1,16	1,34	1,50	1,64	1,77	1,90	2,01	2,12	2,22	2,32
250 mm	0,75	1,06	1,30	1,50	1,68	1,84	1,98	2,12	2,25	2,37	2,49	2,60
315 mm	0,84	1,19	1,46	1,68	1,88	2,06	2,23	2,38	2,53	2,66	2,79	2,92
355 mm	0,89	1,26	1,55	1,79	2,00	2,19	2,36	2,53	2,68	2,83	2,96	3,10
400 mm	0,95	1,34	1,64	1,90	2,12	2,32	2,51	2,68	2,85	3,00	3,15	3,29
450 mm	1,01	1,42	1,74	2,01	2,25	2,46	2,66	2,85	3,02	3,18	3,34	3,49
500 mm	1,06	1,50	1,84	2,12	2,37	2,60	2,81	3,00	3,18	3,35	3,52	3,67
630 mm	1,19	1,68	2,06	2,38	2,66	2,92	3,15	3,37	3,57	3,76	3,95	4,12

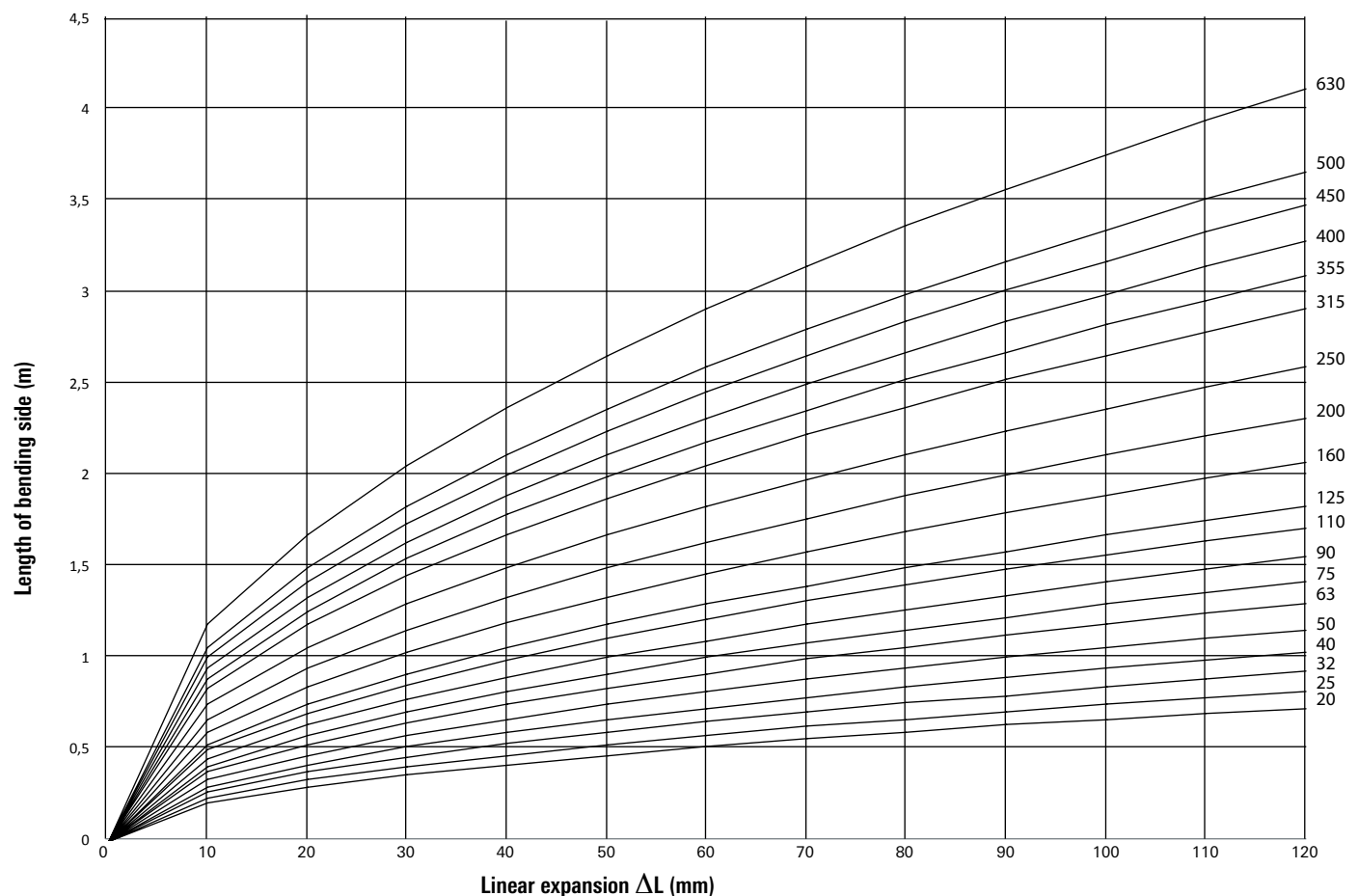

LENGTH OF BENDING SIDE WITH PRE-STRESS

for aquatherm polypropylene pipes The length of the bending side with pre-stress L_{BSV} can be taken from the tables and graphs in consideration of the applied pipe dimensions and determined linear expansion.

Pipe Dimension	Linear expansion (mm)											
	10	20	30	40	50	60	70	80	90	100	110	120
	Length of bending side (m)											
20 mm	0,15	0,21	0,26	0,30	0,34	0,37	0,40	0,42	0,45	0,47	0,50	0,52
25 mm	0,17	0,24	0,29	0,34	0,38	0,41	0,44	0,47	0,50	0,53	0,56	0,58
32 mm	0,19	0,27	0,33	0,38	0,42	0,46	0,50	0,54	0,57	0,60	0,63	0,66
40 mm	0,21	0,30	0,37	0,42	0,47	0,52	0,56	0,60	0,64	0,67	0,70	0,73
50 mm	0,24	0,34	0,41	0,47	0,53	0,58	0,63	0,67	0,71	0,75	0,79	0,82
63 mm	0,27	0,38	0,46	0,53	0,60	0,65	0,70	0,75	0,80	0,84	0,88	0,92
75 mm	0,29	0,41	0,50	0,58	0,65	0,71	0,77	0,82	0,87	0,92	0,96	1,01
90 mm	0,32	0,45	0,55	0,64	0,71	0,78	0,84	0,90	0,95	1,01	1,06	1,10
110 mm	0,35	0,50	0,61	0,70	0,79	0,86	0,93	0,99	1,06	1,11	1,17	1,22
125 mm	0,38	0,53	0,65	0,75	0,84	0,92	0,99	1,06	1,13	1,19	1,24	1,30
160 mm	0,42	0,60	0,73	0,85	0,95	1,04	1,12	1,20	1,27	1,34	1,41	1,47
200 mm	0,47	0,67	0,82	0,95	1,06	1,16	1,25	1,34	1,42	1,50	1,57	1,64
250 mm	0,53	0,75	0,92	1,06	1,19	1,30	1,40	1,50	1,59	1,68	1,76	1,84
315 mm	0,60	0,84	1,03	1,19	1,33	1,46	1,58	1,68	1,79	1,88	1,97	2,06
355 mm	0,63	0,89	1,09	1,26	1,41	1,55	1,67	1,79	1,90	2,00	2,10	2,19
400 mm	0,67	0,95	1,16	1,34	1,50	1,64	1,77	1,90	2,01	2,12	2,22	2,32
450 mm	0,71	1,01	1,23	1,42	1,59	1,74	1,88	2,01	2,13	2,25	2,36	2,46
500 mm	0,75	1,06	1,30	1,50	1,68	1,84	1,98	2,12	2,25	2,37	2,49	2,60
630 mm	0,84	1,19	1,46	1,68	1,88	2,06	2,23	2,38	2,53	2,66	2,79	2,92

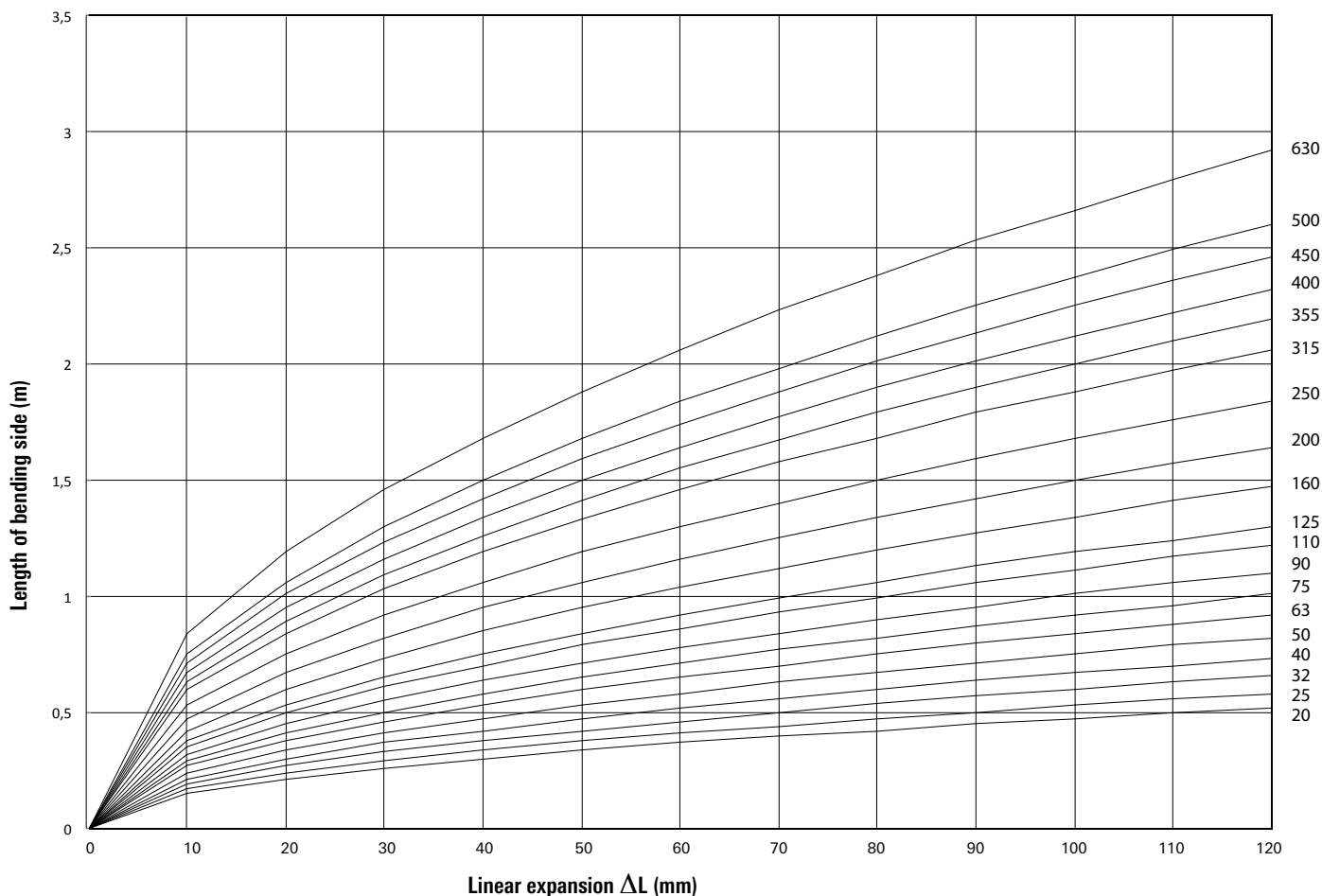

SUPPORT INTERVALS

aqualtherm blue pipe SDR 11 S

Table to determine support intervals in conjunction with temperature and outside diameter.

Pipe diameter d (mm)		
20	25	32
Support intervals in cm		
60	75	90

aqualtherm blue pipe SDR 17.6 MF

Table to determine support intervals in conjunction with temperature and outside diameter.

Difference in temperature ΔT [K]	Pipe diameter d (mm)									
	125	160	200	250	315	355	400	450	500	630
	Support intervals in cm									
0	255	260	265	275	280	285	295	305	315	330
20	185	190	200	205	210	215	230	240	255	280
30	175	180	190	195	200	205	220	230	245	275
40	170	175	180	190	190	195	210	225	235	265
50	160	165	175	180	185	190	200	215	230	255
60	150	155	165	170	175	180	185	200	215	240
70	140	145	155	160	170	175	180	190	205	230

aqualtherm blue pipe SDR 7.4 MF (fibre composite pipe)

Table to determine support intervals in conjunction with temperature and outside diameter.

Difference in temperature ΔT [K]	Pipe diameter d (mm)		
	20	25	32
	Support intervals in cm		
0	120	140	160
20	90	105	120
30	90	105	120
40	85	95	110
50	85	95	110
60	80	90	105
70	70	80	95

SUPPORT SPACINGS PP PIPE AND FIBRE COMPOSITE PIPE

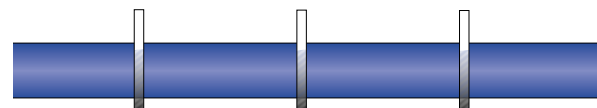

PP pipe



Fibre composite pipe approx. 30 % more fixing distance

aqualtherm blue pipe SDR 11 MF (fibre composite pipe)

Table to determine support intervals in conjunction with temperature and outside diameter.

Difference in temperature ΔT [K]	Pipe diameter d (mm)														
	32	40	50	63	75	90	110	125	160	200	250	315	355	400	450
	Support intervals in cm														
0	150	170	195	220	235	250	275	280	285	290	300	310	315	325	325
20	110	125	145	165	175	185	200	205	210	220	225	230	235	250	265
30	110	125	145	165	175	185	190	195	200	210	215	220	225	240	255
40	100	115	135	155	165	175	180	185	190	200	210	210	215	230	245
50	100	115	135	155	160	170	170	175	180	190	200	205	205	220	235
60	95	110	125	145	150	160	160	165	170	180	185	190	195	205	220
70	85	100	120	135	140	145	150	155	160	170	175	185	190	195	210

Pipe clamp distances of vertically installed pipes can be increased by 20 % of the tabular values, e.g. to multiply the tabular value by 1.2.

THERMAL INSULATION OF HOT WATER PIPES

minimum insulation thickness in [mm] against condensation

medium temperature 5 °C - thermal conductivity value of caoutchouc insulation 0.040 W/(mK)												
Dimension	humidity	ambient temperature										
		20 °C	22 °C	24 °C	26 °C	28 °C	30 °C	32 °C	34 °C	36 °C	38 °C	40 °C
75mm	50 %		1	1	2	2	3	3	4	4	5	5
	60 %	2	3	3	4	5	5	6	7	7	8	8
	70 %	5	6	7	8	8	9	10	11	12	13	13
	80 %	9	11	12	14	15	17	18	19	20	21	22
110mm	50 %				1	2	2	3	3	4	4	4
	60 %	1	2	3	3	4	5	5	6	7	7	8
	70 %	4	5	6	7	8	9	10	10	11	12	13
	80 %	9	11	12	14	15	17	18	19	20	21	22
160mm	50 %						1	1	2	2	3	3
	60 %		1	1	2	3	4	4	5	5	6	7
	70 %	3	4	5	6	7	8	9	9	11	11	12
	80 %	8	10	11	13	14	16	17	19	20	21	22

The decree for energy saving thermal protection and energy saving installation engineering for buildings (EnEV energy saving regulation) regulates the thermal insulation of hot water supplies and fittings in Germany.

Central heating pipes, line 1–4 installed in heated rooms or building parts between heated rooms of the one user, where heat output can be controlled by open stop valves do not require a minimum thickness of the insulation.

This even applies to hot water pipes up to an inner diameter of 22 mm in flats, which are neither in the circulation nor have an additional electric heating. Applying material with thermal conductivities different to 0.035 W/(mK) the minimum thickness of the insulation has to be converted correspondingly.

For the conversion and the thermal conductivity of the insulation the ways and values of calculation described in the technical regulations must be applied.

The minimum insulation according to the table for heating distributions and heating pipes can be reduced as far as the same limit of heat output even for further insulation requirements in consideration of the insulating effect of the pipe walls are guaranteed.

Cooling pipes must be provided with suitable insulation to prevent condensation. For further information please contact our service hotline +49 2722 950 200

EnEV 2019, § 14, addendum 5, chart 1

Thermal insulation of heat distribution and hot water pipes, cold distribution and cold water pipes and fittings

Line	Type of pipe/fitting	minimum thickness of insulation referred to thermal conductivity of 0.035 W/(mK)
1	inner diameter up to 22 mm	20 mm
2	inner diameter more than 22 mm up to 35 mm	30 mm
3	inner diameter more than 35 mm up to 100 mm	same as inner diameter
4	inner diameter more than 100 mm	100 mm
5	pipes and fittings after line 1–4 in wall- and ceiling openings, in crossing area of pipes, at pipe connections, at distributors	½ of the requirements of line 1 to 4
6	pipes of central heating after line 1–4, which have been installed after 31. January 2002 between heated rooms of various users	½ of the requirements of line 1 to 4
7	pipes after line 6 in floor construction	6 mm
8	Cooling distribution and cold water pipes and fittings of air handling and air conditioning systems	6 mm

If in cases of § 14, paragraph 5 the heat distribution and hot water pipes border on outside air, they must be insulated with twice the minimum thickness according to table 1, lines 1 to 4.

INSULATION THICKNESS ACCORDING TO ENERGY SAVING REGULATION

According to energy saving regulation (EnEV) aquatherm pipes and fittings have to be insulated against loss of heat. The insulation thickness depends on the respective installation.

The heat conductivity figure of fusiolen® polypropylene is 0.15 W/(mK). aquatherm pipes and fittings offer a significantly higher degree of insulation compared to metal pipes.

Due to the high insulation values of fusiolen® the insulation thickness – compared to metallic pipe systems – can be reduced.

Undermentioned are the recommendation based on EnEV 2009. Regional standards might vary and are to be considered.

It is possible to reduce the thickness of insulation layer by approximately 50%, this depends on local and operating conditions.

Thermal insulation from heat distribution and hot water pipes, cooling distribution and cold water pipes according to EnEV 2009

Minimum thickness of insulation referred to thermal conductivity of 0.035 W/(mK)

pipe diameter	*50 %	*100 %
16 mm	10 mm	20 mm
20 mm	10 mm	20 mm
25 mm	10 mm	20 mm
32 mm	15 mm	30 mm
40 mm	15 mm	30 mm
50 mm	18 mm	35 mm
63 mm	23 mm	45 mm
75 mm	28 mm	55 mm
90 mm	33 mm	65 mm
110 mm	40 mm	80 mm
125 mm	45 mm	90 mm
160 mm	50 mm	100 mm
200 mm	50 mm	100 mm
250 mm	50 mm	100 mm
315 mm	50 mm	100 mm
355 mm	50 mm	100 mm
400 mm	50 mm	100 mm
450 mm	50 mm	100 mm
500 mm	50 mm	100 mm
630 mm	50 mm	100 mm

* The insulation thickness has to be calculated due to the thermal conductivity of polypropylene pipes acc. to test report no.: G.2 - 136/97 of FIW-Munich

PRESSURE TEST/TEST CONTROL/ MEASURING OF THE TEST PRESSURES/TEST RECORD

Pressure test/Test control

All aquatherm pipe systems shall be subjected to a hydraulic pressure test with a test pressure of 10 bar.

The material properties of the aquatherm pipe systems result in an expansion of the pipes during the pressure test. This affects the test result. Due to the thermal expansion coefficients of the aquatherm pipe systems the results are influenced additionally. The temperature differences between the pipe and the test medium lead to changes in pressure. Hereby a temperature change of 10 K corresponds to a pressure difference of 0.5 up to 1 bar.

Therefore pressure testing of the aquatherm pipe systems should be made with a constant temperature of the test medium. The hydraulic pressure test requires a preliminary, principal and final test.

In the preliminary test a pressure of **18 bar*** is applied 3 x 5 minutes for the expansion/release of the pipes. Between the cycles the pipe system must be depressurized.

Immediately after the preliminary test the principal test should be performed. The test duration is 15 min. Here, the test pressure (10 bar) may not fall more than 0.5 bar.

After completion of the preliminary and principle test finally the final test must be performed.

The test duration is 60 minutes. Here, the test pressure – read after the principle test – may not fall more than 0.5 bar.

Measuring of the test pressures

When measuring the system use a pressure measuring device that is able to read a pressure change of 0.1 bar. Place the measuring device at the lowest point (highest static pressure) of the installation.

Test record

A record of the hydraulic pressure test has to be prepared and signed by the client and contractor stating place and date (see page 85).

* Exception: aquatherm blue pipe SDR 17.6: 10 bar

LEAKAGE TEST/PRESSURE DIAGRAM

PRELIMINARY TEST

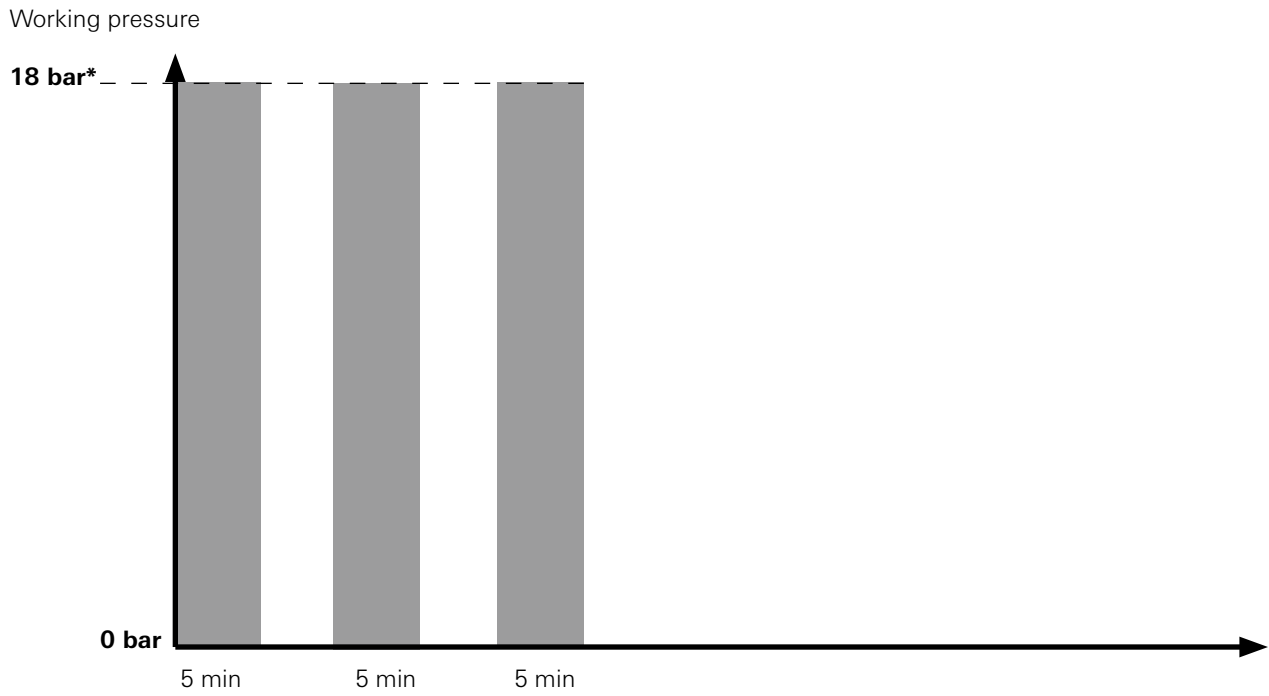

PRINCIPAL AND FINAL TEST

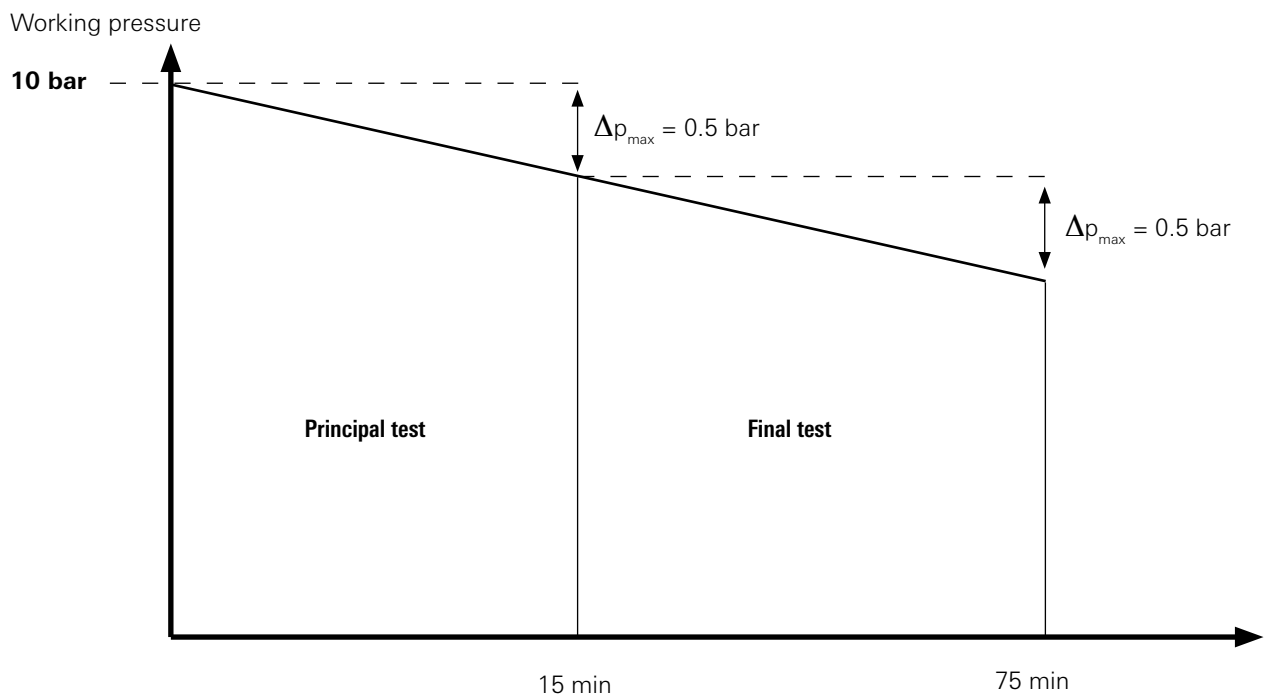

* Exception: aquatherm blue pipe SDR 17.6: 10 bar

TEST RECORD AQUATHERM SYSTEM INSTALLATION

Place: _____

Object: _____

Note before the test:

3 x 5 minutes system pressure of 18 bar or 10 bar for expansion/release of the pipes are required.

Preliminary test for SDR 6, SDR 7.4 and SDR 11

The pipe system must be unpressurized between each cycle.

18 bar 5 min realized: yes no

18 bar 5 min realized: yes no

18 bar 5 min realized: yes no

Preliminary test for SDR 17.6

The pipe system must be unpressurized between each cycle.

10 bar 5 min realized: yes no

10 bar 5 min realized: yes no

10 bar 5 min realized: yes no

Principal test

Test pressure: **10** bar

Pressure decline after 15 min: _____ bar **max. 0.5 bar**

Final test

(directly after the principal test, without changing the pressure)

Result principal test: _____ bar

Pressure decline after 60 min: _____ bar **max. 0.5 bar**

Notes: _____

Place, Date

Stamp/Signature

DESCRIPTION OF INSTALLATION

Place: _____

Object: _____

Pipe length:

Ø 20 mm	_____	m	Ø 160 mm	_____	m
Ø 25 mm	_____	m	Ø 200 mm	_____	m
Ø 32 mm	_____	m	Ø 250 mm	_____	m
Ø 40 mm	_____	m	Ø 315 mm	_____	m
Ø 50 mm	_____	m	Ø 355 mm	_____	m
Ø 63 mm	_____	m	Ø 400 mm	_____	m
Ø 75 mm	_____	m	Ø 450 mm	_____	m
Ø 90 mm	_____	m	Ø 500 mm	_____	m
Ø 110 mm	_____	m	Ø 630 mm	_____	m
Ø 125 mm	_____	m			

Start of test: _____

End of test: _____

Test period: _____

Test medium: water water/glycol











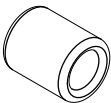



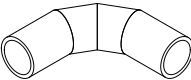

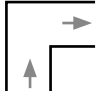
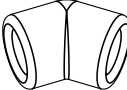

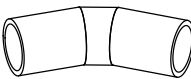

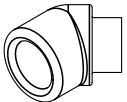
Client: _____

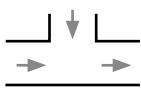
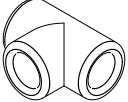
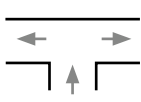
Contractor: _____

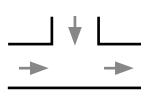
Place, Date

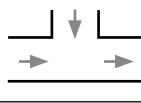

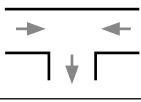
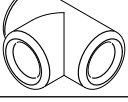
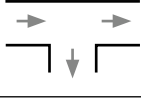
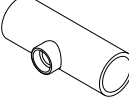
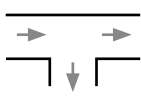

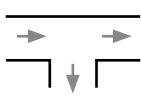





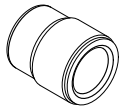

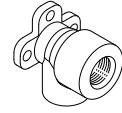

Stamp/Signature

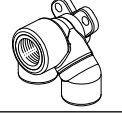
Coefficient of loss ζ aquatherm green pipe- & aquatherm blue pipe-fittings

Fitting	Drawing	Graphic illustration	ζ -Value																			
			16	20	25	32	40	50	63	75	90	110	125	160	200	250	315	355	400	450	500	630
Socket			0,8	0,5	0,5	0,7	0,9	0,2	0,2	0,2	0,2	0,2	0,2	0,2	0,2	0,2	0,2	0,2	0,2	0,2	0,2	0,2
Elbow 90°			2	1,3	1,2	2	1,9	0,5	0,5	0,7	0,7	0,7	0,7	0,7	0,7	0,7						
Segment Elbow 90°																0,8	0,8	0,8	0,8	0,8	0,8	0,8
Elbow 90° m.f.				1,3	1,2	2	1,9															
Elbow 45°				2	1,9	1,9	0,5	0,4	0,4	0,4	0,4	0,4	0,4	0,4	0,4	0,4						
Elbow 45°																0,4	0,4	0,4	0,4	0,4	0,4	0,4
Elbow 45° m.f.				2	1,9	1,9	0,5															
Tee			1,1	0,9	0,9	0,9	0,6	0,2	0,2	0,2	0,2	0,2	0,2	0,2	0,2	0,2	0,2	0,2	0,2	0,2	0,2	0,2
Tee			0	0,3	0,3	0,4	0,7	0,7	1,1	1,3	1,3	1,3	1,3	1,3	1,3	1,3	1,3	1,3	1,3	1,3	1,3	1,3
Tee			2	1,9	1,8	1,8	1,6	1,6	1,6	2	2	2	2	2	2	2	2	2	2	2	2	2
Tee			3,8	3,5	3,2	3,2	3	3,2	3,2	4	4	4	4	4	4	4	4	4	4	4	4	4
Tee			2,2	2,3	2,3	2	1,6	1,9	1,9	2,7	2,7	2,7	2,7	2,7	2,7	2,7	2,7	2,7	2,7	2,7	2,7	2,7
Tee			2,4	2,6	1,4	2,3	1,8	1,2	1,1	1,2	1,2	1,2	1,2	1,2	1,2	1,2	1,2	1,2	1,2	1,2	1,2	1,2
Reducing tee (saddle technology)			The zeta value results from the addition of the zeta values T-piece and Red-piece																			
Reducing tee			The zeta value results from the addition of the zeta values T-piece and Red-piece																			

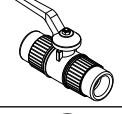
(→ = flow direction)

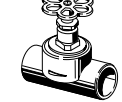
Coefficient of loss ζ aquatherm green pipe- & aquatherm blue pipe-fittings

Fitting	Drawing	Graphic illustration	ζ -Value																			
			16	20	25	32	40	50	63	75	90	110	125	160	200	250	315	355	400	450	500	630
Reducer			2,4	1,9	1,9	1,9	0,2	0,2	0,2	0,2	0,2	0,2	0,2	0,2	0,2	0,2	0,2	0,2	0,2	0,2	0,2	0,2
Back plate				3,7	3,7																	
Back plate				3,5	3,5																	
Back plate				2	2																	
Stop valve/ inclined valve				2	2	2	2															
Ball valve				0,3	0,3	0,3	0,3	0,3	0,3	0,3	0,3	0,3	0,3	0,3	0,3	0,3	0,3	0,3	0,3	0,3	0,3	0,3
Screw-down stop globe valve				7	7	7	7															

(→ = flow direction)

Source: DIN 1988 Part 3

$$Z = \frac{\zeta v^2 \delta}{2}$$

Z = Pressure lost in [Pa]

v = Flow rate [m/s]

ζ = Coefficient of loss of fitting

δ = Density of medium [kg/m³]

K_v = volume flow [m³/h] of water [5–30 °C] at a pressure difference of 1 bar

Note: For the determination of pressure loss in (mbar) the result has to be divided by the factor 100 (100Pa = 1 mbar).

Notice on planning & design of compressed air applications

When planning and designing pipe systems for compressed air applications, the following working pressures are to be observed.

aquatherm blue pipe SDR 11	aquatherm green pipe SDR 9
10 bar	10 bar

This chart is valid for temperatures from 10 °C to 40 °C. For temperatures and conditions other than those noted in the chart, please contact our technical service department.

Warning: Failure of a compressed gas (air or inert gas) system can be extremely violent and dangerous. In a compressed gaseous media piping system, energy is applied to compress the gaseous media in addition to pressurizing the system. If failure occurs, both energies can be suddenly released and can be extremely violent compared to failure during leak testing or system operation with an incompressible liquid testing media.

aquatherm recommends that thermoplastics piping intended for the transport of compressed air or other compressed gases should be installed by burial, encasement in shatter-resistant material or other appropriate means, to prevent or minimize the possibility of mechanical damage. The piping must also be protected from other sources of degradation such as ultraviolet light (UV) exposure, chemical effects, temperature and oxidation.

Always make sure to eliminate risks for persons near compressed air systems, also observing the applicable national and international regulations of installation, accident prevention and safety for the installation of pipe systems, as well as the applicable laws, standards, guidelines and technical rules.

CHEMICAL RESISTANCE OF PIPES AND FITTINGS

The following chemical resistance document can be used as a general guideline, but should not be considered a formal recommendation or approval by aquatherm. The actual behavior of the piping system when exposed to a specific chemical is very dependent on the exposure conditions (temperature, pressure, flow, duration, etc.), the stresses on the piping material and system (mechanical, thermal, cyclic, etc.), and the ancillary materials in the system (o-rings, seals, gaskets, metal components, etc). Due to the comprehensive warranty provided by aquatherm, specific applications must be submitted to aquatherm for review and evaluation using the form in the technical catalogue or the online submittal form. A written response will be provided once the review is completed. The attached guidance document should **NOT** be used as a definitive reference for determining the chemical compatibility of aquatherm piping in a specific application. This can only be determined by submitting the information to aquatherm for review.

Polypropylene (PP) pipes; chemical resistance of pipes and pipe fittings.

The behavior of pipes and pipe fittings towards flow substances depends on the one hand on the particular nature and type of plastic, the design of the pipe fitting and the manufacturing conditions, and, on the other hand, on the nature of the flow substance. In particular, the duration of the action, temperatures and mechanical stresses acting at the same time and other types of influences which additionally have an effect also determine the behavior. The effects of these influences, which frequently are not clearly foreseeable at the outset, are decisive for the suitability for an application. Furthermore, special requirements on the pipe or pipe fitting (e.g. dimensional stability or mechanical strength) shall be taken into consideration, depending on the application.

For these reasons, the suitability of pipes and pipe fittings for a flow substance can be evaluated only from case to case.

The chemical resistance indicates the gradual behavior of the material of the pipe wall towards the action of the flow substance. It depends in each case on the type of interacting substances, their composition, the temperature and the duration of the action.

In an application, the chemical resistance can be influenced by further stresses (e.g. of a mechanical nature).

Note: The chemical resistance does not correspond to the term "chemical stability" hitherto used in everyday language, because this contains an evaluation for the particular application.

Data on chemical resistance

Various processes may occur when the flow substances come into contact with the material of the pipe wall, such as absorption of the liquid (swelling), extraction of soluble constituents of the material (shrinkage) and chemical reactions (hydrolysis, oxidation and the like), which in certain circumstances may cause changes in the properties of the pipes and pipe fittings.

The behavior of the pipes and pipe fittings towards the flow substances is classified into the following groups:

- : **resistant**
The material of the pipe wall is generally evaluated as suitable.
- ◐: **conditionally resistant**
The suitability of the material of the pipe wall for the particular application shall be investigated; if necessary, further experiments shall be carried out.
- : **not resistant**
The material of the pipe wall is generally evaluated as unsuitable.
- : No data on the chemical resistance is available

Detailed information regarding the resistance of our pipe systems to the listed fluids can be obtained from the aquatherm laboratory:

Hotline +49 2722 950 0

For inquiries on resistance, medium and operating conditions (operating pressure and temperature) needs to be specified.

¹⁾ Table taken from the English translation of DIN 8078 Supplement 1, Feb. 1982, Chemical resistance of (PP-) pipes and pipe fittings. Reproduction with the permission of DIN Deutsches Institut für Normung e. V.. Important: When applying said standard the edition with the most recent release date should be used (can be purchased at Beuth Verlag GmbH, Burggrafenstrasse 6, 10787 Berlin, Germany).

The following designations are used for the composition of the flow substances:

- a) If the content data is not followed by "(Vol.)", the data is the weight in % (previously % by weight) .
 - VL: aqueous solution, the weight content of which is ≤ 10 %.
 - L: aqueous solution, the weight content of which is greater than 10 %.
 - GL: saturated (at 20 °C) aqueous solution.
 - TR: flow substance is as least technically pure.
 - H: commercially available composition.

- b) Volume content in % (previously % by volume): this is characterized specially by "(Vol)".
The chemical resistance of pipes and pipe fittings is generally not reduced for weight or volume contents and temperatures lower than those given in the table.

²⁾ These flow substances and/or chemical resistance data are not contained in ISO/TR 7471.

³⁾ The chemical resistance is evaluated as one group lower in ISO/TR 7471.

⁴⁾ The chemical resistance is evaluated as one group higher in ISO/TR 7471.

CHEMICAL RESISTANCE

Due to their special material properties aquatherm green pipe resp. aquatherm blue pipe and fittings are generally chemical resistant. However, aquatherm green pipe transition elements with thread inserts made of brass are not suitable for all media.

For industrial application of aquatherm green pipe and aquatherm blue pipe we recommend to use aquatherm green pipe flanges and/or coupling screws.

Note: On request, you will receive threaded inserts for aquatherm green pipe connecting pieces also in stainless steel. Prices on request.

INQUIRY FOR THE CHEMICAL RESISTANCE OF THE AQUATHERM GREEN PIPE AND AQUATHERM BLUE PIPE SYSTEM:

aquatherm GmbH

Biggen 5 · 57439 Attendorn · Germany

Phone: +49 2722 950 0

info@aquatherm.de · www.aquatherm.de

Installer:

Company

Contact

Street

PC/City

Phone

Fax

E-mail

Building project:

Address:

Street

PC/City

Place, Date/Signature

Field of application:

Flow medium

Operating temperature

°C/°F

Working pressure

bar/psi

Service life

h/d

Concentration

%

Ambient medium:

Ambient temperature

°C/°F

Ambient pressure

bar/psi

	Data sheets	enclosed	not enclosed
Fluid transported	<input type="checkbox"/>	<input type="checkbox"/>	<input type="checkbox"/>
Ambient medium	<input type="checkbox"/>	<input type="checkbox"/>	<input type="checkbox"/>

Flow Substance	Content ¹⁾ %	Behavior at	
		20 °C / 68 °F	60 °C / 140 °F
Waste gases ²⁾ or air/gas mixtures			
- containing hydrogen fluoride	traces	●	●
- containing carbon dioxide	any	●	●
- containing carbon monoxide	any	●	●
- containing nitroses (nitrogen oxide)	traces	●	●
- containing hydrochloric acid	any	●	●
- containing sulphur dioxide	any	●	●
- containing sulphuric acid	any	●	●
- containing sulphur: trioxide (oleum)	traces	○	○
Acetaldehyde ²⁾	TR	◐	–
Acetaldehyde, aqueous ²⁾	40 %	●	●
Acetic anhydric (acetic acid anhydride)	TR	●	–
Acetone	TR	●	●
Acetophenone	TR	●	◐
Acrylonitrile	TR	●	● ²⁾
Adipic acid ²⁾	GL	●	●
Malic acid	L	●	●
Caustic soda see sodium hydroxide solution	up to 60 %	●	●
Battery acid ²⁾	H	●	●
Alums (Me(I)-Me(III)-sulphates) ²⁾	GL	●	●
Allyl alcohol (prop-2-en-1-ol), aqueous ²⁾	96 %	●	●
Aluminium chloride ²⁾	GL	●	●
Aluminium sulphate ²⁾	GL	●	●
Formic acid, aqueous	10 %	●	●
Formic acid, aqueous	85 %	●	◐ ³⁾
2 - Aminoethanol (ethanolamine)	TR	●	–
Ammonia, liquid	TR	●	–
Ammonia, gaseous	TR	●	● ²⁾
Aqueous ammonia (ammonia solution)	GL	●	● ²⁾
Ammonium acetate	GL	●	●
Ammonium carbonate ²⁾ and bicarbonate	GL	●	●
Ammonium chloride	GL	●	● ²⁾
Ammonium fluoride	L	●	●
Ammonium nitrate	GL	●	●
Ammonium phosphate ²⁾	GL	●	●
Ammonium sulphate	GL	●	●
Ammonium sulphide ²⁾	GL	●	●
Amyl acetate (acetate (acetic acid isoamyl ester)	TR	◐	–
Amyl alcohol (fermentation amyl alcohol)	TR	●	●
Aniline	TR	◐ ⁴⁾	◐ ⁴⁾
Anilium chloride (aniline hydrochloride)	GL	●	●
Anisole ²⁾	TR	◐	◐
Anone see cyclohexanone	TR	◐	○
Antimony(III) chloride, aqueous ²⁾	90 %	●	●
Apple juice	H	●	● ²⁾

Flow Substance	Content ¹⁾ %	Behavior at	
		20 °C / 68 °F	60 °C / 140 °F
Malic acid	L	●	●
Apple wine ²⁾	H	●	●
Arsenic acid, ortho, aqueous ²⁾	10 %	●	●
Arsenic acid, ortho, aqueous ²⁾	80 %	●	●
Barium hydroxide	GL	●	●
Barium salts ²⁾	GL	●	●
Cottonseed oil	TR	●	●
Benzaldehyde ²⁾	GL	●	●
Benzaldehyde ²⁾	L	●	–
Benzine (aliphatic hydrocarbons)	H	◐ ³⁾	○
Benzine/benzene mixture ²⁾	80 %/20 % (Vol.)	◐	○
Benzoic acid	GL	●	● ²⁾
Benzene	TR	◐	○
Benzoyl chloride ²⁾	TR	◐	–
Benzyl alcohol	TR	●	◐
Succini acid	GL	●	●
Beeswax ²⁾	H	●	◐
Beer ²⁾	H	●	●
Caramel ²⁾	VL	●	●
Hydrocyanic acid ²⁾ (hydrogen cyanide)	TR	●	●
Lead acetate ²⁾	GL	●	●
Bleaching liquor (sodium hypochlorite)	20 %	◐ ⁴⁾	◐
Lead tetraethyl (tetraethyl-lead) ²⁾	TR	●	–
Borax (sodium tetraborate)	L	●	●
Boric acid	GL	●	● ²⁾
All types of spirits ²⁾	H	●	●
Bromine (bromine water) ²⁾	GL	◐	○
Bromine, gaseous	any	◐	○
Bromine, liquid	TR	○	○
Bromomethyl see methyl bromide	TR	○	○
Hydrobromic acid, aqueous	48 %	●	◐
Butane, gaseous	TR	●	● ²⁾
Butadiene, gaseous ²⁾	TR	◐	○
Butanols (butyl alcohols)	TR	●	◐
Butane-1,2,4-triol ²⁾	TR	●	●
But-2-ene-1,4-diol ²⁾	TR	●	●
But-2-ine-1,4-diol ²⁾	TR	●	–
Butyric acids, aqueous	20 %	●	–
Butyl acetates(acetic acid butyl esters)	TR	◐	○
Butylenes, liquid ²⁾ (butenes)	TR	◐	–
Butylene glycols (butanediols) aqueous ²⁾	10 % (Vol.)	●	◐
Butylene glycols (butanediols) ²⁾	TR	●	●
Butylglycol (ethylene glycol monobutyl ether)	TR	●	–
Butylphenols	GL	●	–
Butylphenone ²⁾	TR	○	–

Flow Substance	Content ¹⁾ %	Behavior at	
		20 °C / 68 °F	60 °C / 140 °F
Butyl phthalate (dibutyl phthalate)	TR	●	◐
Calcium carbonate	GL	●	●
Calcium chloride	GL	●	●
Calcium hydroxide	GL	●	●
Calcium hypochlorite	L	●	–
Calcium nitrate	GL	●	●
Camphor oil	TR	○	○
Carbolineum ²⁾	H	●	–
Chlorine, gaseous, dry	TR	○	○
Chlorine, gaseous, moist ²⁾	0.50 %	◐	–
Chlorine, gaseous, moist ²⁾	1 %	○	○
Chlorine, liquid	TR	○	○
Chloral ²⁾ (trichloroacetaldehyde)	TR	●	●
Chloral hydrate ²⁾	TR	◐	○
Chloramine ²⁾	L	●	–
Chlorobenzene ²⁾	TR	◐	–
Chloroacetic acid, mono, aqueous	L	●	● ²⁾
Chloroacetic, mono, aqueous	85 % 2)	●	●
Chloroethane (ethyl chloride)	TR	○	○
2-Chloroethanol (ethylene chlorohydrin)	TR	●	● ²⁾
Bleaching powder suspension in water ²⁾	any	●	●
Chloroform (trichloromethane)	TR	◐	○
Chloric acid, aqueous ²⁾	1 %	●	◐
Chloric acid, aqueous ²⁾	10 %	●	◐
Chloric acid, aqueous	20 %	●	○
Chlorosulphonic acid (chlorosulphuric acid)	TR	○	○
Hydrogen chloride, dry gas	TR	●	●
Hydrogen chloride, moist gas ²⁾ (hydrochloric acid)	TR	●	●
Chrome alum (alums)	GL	●	●
Chromic acid, aqueous	40 %	◐ ⁴⁾	◐
Chromic acid/sulphuric acid/water ²⁾ (chromic/sulphuric acid)	15/35/50 %	○	○
Citric acid	VL	●	●
Crotonaldehyde ²⁾ (2-butenal)	TR	●	–
Potassium cyanide	L	●	● ²⁾
Cyclohexane	TR	●	–
Cyclohexanol	TR	●	◐
Cyclohexanone	TR	◐	○
Dekalin (decahydronaphthalene)	TR	◐ ³⁾	○
Dextrin (starch gum)	L	●	●
Dextrose (glucose)	20 %	●	●
1,2-Diaminoethane (ethylenediamine) ²⁾	TR	●	●

Flow Substance	Content ¹⁾ %	Behavior at	
		20 °C / 68 °F	60 °C / 140 °F
Di-n-butyl ether ²⁾	TR	◐	○
Dibutyl phthalate (phehalic acid dibutyl ester)	TR	●	◐
Dichloroethylene (1,1- and 1,2-)	TR	◐	–
Dichlorobenzenes ²⁾	TR	◐	–
Dichloroacetic acid	TR	◐	–
Dichloroacetic acid, aqueous ²⁾	50 %	●	●
Dichloroacetic acid methyl ester ²⁾	TR	●	●
Diesel fuel ²⁾	H	●	◐
Diethanolamine	TR	●	–
Diethyl ether (ether)	TR	●	◐
Diglycollic acid	GL	●	● ²⁾
Dihexyl phthalate ²⁾	TR	●	◐
Diisobutyl ketone ²⁾ (2,6-dimethylheptan-4-one)	TR	●	○
Diisopropyl ether	TR	◐	○ ²⁾
Diisooctyl phthalate	TR	●	◐
Dimethylamine, gaseous	100 %	●	–
N, N-Dimethylformamide	TR	●	●
Dinonyl phthalate ²⁾ (DNP)	TR	●	◐
Dioctyl phthalate (DOP)	TR	● ³⁾	◐
1,4-dioxane (diethylene dioxide)	TR	◐	◐
Fertilizer salts ²⁾	GL	●	●
Iron (II) and (III) chloride ²⁾	GL	●	●
Natural gas	TR	●	–
Peanut oil	TR	●	●
Vinegar (wine vinegar)	H	●	●
Acetic acid, aqueous (glacial acetic acid)	TR	●	◐
Acetic acid, aqueous and vinegar essence	50 %	●	●
Acetic acid, aqueous	up to 40 %	●	●
Acetic acid anhydride	TR	●	–
Acetic acid ethyl ester (ethyl acetate)	TR	● ³⁾	◐ ³⁾
Acetic acid methyl ester (methyl acetate)	TR	●	●
Ethanol (ethyl alcohol)	TR	●	●
Ethanol, denatured with 2 % of toluene ²⁾	96 % (Vol.)	●	–
Ethylbenzene ²⁾	TR	◐	○
Ethyl chloride, gaseous (chloroethane)	TR	○	○
Ethylene chlorohydrin (chloroethanol)	TR	●	: ²⁾
Ethylenediamine (1,2-diaminoethane)	TR	●	●
Ethylene glycol	TR	●	●
Ethylene oxide, liquid ²⁾ (oxirane)	TR	○	–
Fatty acids (from C ₄) ²⁾	TR	●	◐
Pine-needle oil ²⁾	H	●	◐
Fluorine, dry ²⁾	TR	◐	–
Fluorosilicic acid ²⁾ , aqueous	32 %	●	●
Hydrofluoric acid, aqueous ²⁾	40 %	●	●

Flow Substance	Content ¹⁾ %	Behavior at	
		20 °C / 68 °F	60 °C / 140 °F
Hydrofluoric acid, aqueous ²⁾	70 %	●	◐
Formaldehyde, aqueous	40 %	●	● ²⁾
Photo emulsions ²⁾	H	●	●
Photo developer baths ²⁾	H	●	●
Photo fixing baths ²⁾	H	●	●
Antifreeze (automobiles) ²⁾	H	●	●
Fruit drinks and fruit juices	H	●	●
Fructose (fruit sugar)	L	●	●
Furfuryl alcohol ²⁾	TR	●	◐
Fermentation mash ²⁾	H	●	●
Gelatine	L	●	●
Tannin extract, vegetable ²⁾	H	●	○
Tannic acid (tannin), aqueous ²⁾	10 %	●	○
Glucose, aqueous	20 %	●	●
Glycerol	TR	●	●
Glycollic acid, aqueous	30 %	●	◐ ²⁾
Urea	GL	●	● ²⁾
Yeast ²⁾	any	●	–
Heating Oil ²⁾	H	●	◐
Heptanes	TR	● ³⁾	◐ ³⁾
Hexanes	TR	●	◐
Hexane-1,2,6-triol ²⁾	TR	●	●
Hydrazine hydrate ²⁾	TR	●	–
Hydroquinone ²⁾	L	●	–
Hydroxylammonium sulphate ²⁾	12 %	●	●
Isooctane	TR	● ³⁾	◐ ³⁾
Isopropanol (propan-2-01)	TR	●	●
Tincture of iodine	H	●	◐ ²⁾
Potassium hydroxide solution, aqueous	50 %	●	●
Potassium bromate, aqueous	10 %	●	●
Potassium bromide	GL	●	●
Potassium carbonate (potash)	GL	●	● ²⁾
Potassium chlorate	GL	●	●
Potassium chloride	GL	●	● ²⁾
Potassium chromate	GL	●	●
Potassium cyanide	L	●	● ²⁾
Potassium dichromate ²⁾	GL	●	●
Potassium fluoride	GL	●	●
Potassium hexacyanoferrate-(II) and -(III) ²⁾ (yellow and red potassium ferro- and ferricyanide)	GL	●	●
Potassium bicarbonate	GL	●	●
Potassium iodide	GL	●	● ²⁾
Potassium nitrate	GL	●	●

Flow Substance	Content ¹⁾ %	Behavior at	
		20 °C / 68 °F	60 °C / 140 °F
Potassium perchlorate, aqueous	10 %	●	●
Potassium permanganate	GL	●	○ ²⁾
Potassium peroxodisulphate (potassium persulphate)	GL	●	● ²⁾
Potassium sulphate	GL	●	● ²⁾
Fluoro silicic acid	32 %	●	●
Silicic acid, aqueous ²⁾	any	●	●
Common salt (sodium chloride)	VL	●	●
Aqua regia (HCl/HNO ₃)	75 %/25 %	○	○
Carbon dioxide, gaseous	any	●	●
Carbon dioxide (carbonic acid), aqueous ²⁾	any	●	●
Coconut fat alcohol ²⁾	TR	●	◐
Coconut oil (coconut fat, copra)	TR	●	–
Cresols	90 % ²⁾	●	●
Cresols	>90 %	●	–
Copper(II) chloride	GL	●	●
Copper(I) cyanide ²⁾	GL	●	●
Copper(II) nitrate, aqueous	30 %	●	●
Copper(II) sulphate	GL	●	●
Lanolin (wool fat)	H	●	◐
Linseed oil	H	●	●
Illuminating gas ²⁾	H	●	–
Air	TR	●	●
Magnesium chloride	GL	●	●
Magnesium hydroxide carbonate	GL	●	●
Magnesium salts ²⁾	GL	●	●
Magnesium sulphate	GL	●	●
Maize germ oil	TR	●	◐
Machine oil ²⁾	TR	●	◐
Sea-water	H	●	●
Molasses ²⁾	H	●	●
Menthol ²⁾	TR	●	◐
Methanol (methyl alcohol)	TR	●	●
Methanol (methyl alcohol)	5 %	●	● ³⁾
Methanesulphonic acid, aqueous ²⁾ (methylsulphuric acid)	50 %	◐	◐
Methanesulphonic acid, aqueous ²⁾ (methylsulphuric acid)	50 bis 100 %	◐	○
Methoxybutanol ²⁾	TR	●	◐
Methyl acetate see (acetic acid methyl ester)	TR	●	●
Methylamine, aqueous	32 %	●	–
Methyl bromide (bromomethyl)	TR	○	○
Methyl chloride, gaseous ²⁾ (chloromethyl)	TR	○	○
Methylene chloride (dichloromethane)	TR	◐	○
Methyl ethyl ketone ²⁾	TR	●	◐
Milk	H	●	●
Lactic acid	90 %	●	●
Mineral water	H	●	●

Flow Substance	Content ¹⁾ %	Behavior at	
		20 °C / 68 °F	60 °C / 140 °F
Engine lubrication oils ²⁾	TR	●	◐
Naphtha	H	●	○
Sodium acetate	GL	●	●
Sodium benzoate, aqueous	35 %	●	● ²⁾
Sodium borate-hydrogen peroxide (sodium perbarate)	GL	●	–
Sodium carbonate, aqueous	50 %	●	●
Sodium chlorate	GL	●	● ²⁾
Sodium chloride	VL	●	●
Sodium chlorite, aqueous	2 to 20 %	●	◐
Sodium dichromate	GL	●	●
Sodium hexametaphosphate	L	●	● ²⁾
Sodium bicarbonate	GL	●	●
Sodium bisulphate	GL	●	●
Sodium bisulphite	L	●	–
Sodium hypochlorite, aqueous	10 %	●	–
Sodium hypochlorite, aqueous	20 %	◐ ⁴⁾	◐
Sodium nitrate	GL	●	●
Sodium nitrite ²⁾	G	●	●
Sodium phosphate, tri	GL	●	●
Sodium silicate, (water-glass)	L	●	●
Sodium sulphate	GL	●	●
Sodium sulphide	GL	●	● ²⁾
Sodium sulphite, aqueous	40 %	●	●
Sodium tetraborate	L	●	●
Sodium thiosulphate	GL	●	● ²⁾
Sodium hydroxide solution, aqueous	up to 60 %	●	●
Nickel salts ²⁾	GL	●	●
Nitrobenzene	TR	●	◐
2-Nitrotoluene ²⁾	TR	●	◐
Fruit pulps ²⁾	H	●	–
Octylcresol ²⁾	TR	◐	○
Oils and fats (animal and vegetable)	TR	●	◐
Oleic acid	TR	●	◐
Oleum (H ₂ SO ₄ + SO ₃)	TR	○	○
Olive oil	TR	●	●
Oxalic acid	GL	●	● ³⁾
Ozone ²⁾	0.5ppm	●	◐
Paraffin emulsions ²⁾	H	●	●
Paraffin oil	TR	●	◐
Perchloroethylene (tetrachloroethylene) ²⁾	TR	◐	◐
Perchloric acid, aqueous	20 %	●	● ²⁾
Petroleum ether	TR	● ³⁾	◐

Flow Substance	Content ¹⁾ %	Behavior at	
		20 °C / 68 °F	60 °C / 140 °F
Petroleum	TR	●	◐
Peppermint oil	TR	●	–
Phenol, aqueous	5 %	●	●
Phenol, aqueous	90 %	●	–
Phenylhydrazine ²⁾	TR	◐	◐
Phenylhydrazinium chloride ²⁾	TR	●	◐
Phosgene, gaseous ²⁾ (carbonyl chloride)	TR	◐	◐
Phosphates ²⁾ (inorganic)	GL	●	●
Phosphorus(III) chloride ²⁾	TR	◐	–
Phosphorus oxychloride	TR	◐	–
Phosphoric acid, ortho	85 %	●	●
Phthalic acid ²⁾	GL	●	●
Picric acid (2, 4, 6 - trinitrophenol)	GL	●	–
Propane, gaseous	TR	●	–
Propan-1-ol ²⁾ (propyl alcohol)	TR	●	●
Propargyl alcohol, aqueous ²⁾	7 %	●	●
Propionic acid, aqueous	>50 %	●	● ²⁾
Propylene glycols ²⁾	TR	●	●
Pyridine	TR	◐	◐ ²⁾
Mercury	TR	●	●
Mercury salts ²⁾	GL	●	●
Castor oil	TR	●	●
Aqueous ammonia (ammonia water)	GL	●	● ²⁾
Nitric acid, aqueous	10 %	●	◐ ³⁾
Nitric acid, aqueous	10–50 %	◐	○ ²⁾
Nitric acid, aqueous	>50 %	○	○
Hydrochloric acid, aqueous	up to 20 %	●	●
Hydrochloric acid, aqueous	>20 to 36 %	●	◐ ²⁾
Oxygen	TR	●	–
Lubricating oils ²⁾	H	◐	–
Sulphur dioxide, gaseous	TR	●	● ²⁾
Sulphur dioxide, gaseous (sulphurous acid)	any	●	● ²⁾
Carbon disulphide	TR	○	○
Sulphuric acid, aqueous	10 %	●	●
Sulphuric acid, aqueous	>10 to 80 %	●	●
Sulphuric acid, aqueous	>80 to TR	◐	○
Sulphuric acid, fuming (oleum)		○	○
Hydrogen sulphide, gaseous	TR	●	●
Sea-water	H	●	●
Silver nitrate	GL	●	●
Silver salts ²⁾	GL	●	●
Silicone oil	TR	●	●
Silicone emulsion ²⁾	H	●	●

Flow Substance	Content ¹⁾ %	Behavior at	
		20 °C / 68 °F	60 °C / 140 °F
Soda (sodium carbonate)	50 %	●	●
Soybean oil	TR	●	◐
Spindle oil ²⁾	TR	●	◐
Starch	any	●	●
Starch gum (dextrin)	L	●	●
Starch syrup ²⁾	any	●	●
Sulphuryl chloride ²⁾	TR	○	○
Terpentine oil	TR	○	○
White spirit ²⁾	TR	●	◐
Tetrachloroethane ²⁾	TR	◐	○
Tetrachloroethylene (perchloroethylene)	TR	◐	◐
Carbon tetrachloride (tetrachloromethane)	TR	○	○
Tetrahydrofuran	TR	◐	○
Tetrahydronaphthalene (tetralin)	TR	○	○
Thionyl chloride ²⁾	TR	◐	○
Thiophene	TR	●	◐
Toluene	TR	◐	○
Transformer oil (insulating oil) ²⁾	TR	◐	○
Grape sugar (glucose)	20 %	●	●
Triethanolamine	L	●	–
Trichloroethylene	TR	○	○
Trichloroacetic acid, aqueous	50 %	●	●
Tricresyl phosphate ²⁾ (phosphoric acid tritolyl ester)	TR	●	◐
Drinking water, chlorinated ²⁾	TR	●	●
Triocyl phosphate ²⁾	TR	●	–
Vaseline oil ²⁾	TR	●	◐
Vinyl acetate ²⁾	TR	●	◐
Vinylidene chloride (1,1-dichloroethylene)	TR	◐	–
Detergents ²⁾	VL	●	●
Water, pure	H	●	●
Hydrogen	TR	●	● ²⁾
Hydrogen peroxide, aqueous	30 %	●	◐
Wines	H	●	● ²⁾
Wine vinegar, table vinegar	H	●	●
Tartaric acid, aqueous	10 %	●	●
Xdylene (all isomers)	TR	◐ ³⁾	○
Zinc salts ²⁾	GL	●	●
Tin(II) chloride	GL	●	●
Tin(IV) chloride	GL	●	●
Citric acid	VL	●	●
Sugar syrup ²⁾	H	●	●



aquatherm

state of the pipe

EXPLANATORY COMMENTS ON THE AQUATHERM GMBH WARRANTY

1. Foreword

Thank you very much for making the decision to use a product from aquatherm GmbH, Germany (herein referred to as "aquatherm"). With more than 45 years of experience in the international plastic pipes market, and our trendsetting innovations, we have the expertise needed to offer you engineered piping solutions made in Germany.

The trust placed in the quality of our products has motivated us to offer all pipes and molded, fabricated, machined, and/or assembled parts with a 10-year warranty instead of the standard 2-year warranty required by German law. This extended time covered by warranty is backed by a comprehensive insurance policy from a leading insurance company for our line of business. The warranty period will begin with the date of delivery by aquatherm GmbH, but only becomes effective with the successful pressure test, which must be carried out and documented in accordance with the aquatherm specification.

2. Scope of warranty

The aquatherm warranty protects you from financial loss proven to be caused by material defects, manufacturing defects and/or aquatherm's consulting/engineering services. The warranty coverage shall apply for the following product groups:

- aquatherm green pipe (fusiotherm and aquatherm ISO)
- aquatherm blue pipe (climatherm and aquatherm ISO)
- aquatherm red pipe (firestop)
- aquatherm black system (climasystem)
- aquatherm lilac pipe (aquatherm lilac)
- aquatherm orange system (aquatherm heating systems)
- aquatherm grey pipe (aquatherm SHT system)
- assemblies fabricated by aquatherm from these product groups

2.1 What is covered by the aquatherm warranty?

The aquatherm warranty covers three aspects of damages: property damage, financial loss and personal injury.

2.1.1 What is property damage?

The damage to or destruction of a tangible item as a result of a defective product (e.g. classic water damages as a result of a leak). As a result of this, the suitability of the tangible item to fulfill its actual purpose is impaired. The term property damage is used if tangible items are damaged or destroyed. Considerable costs can be incurred as a result of property damage, such as renovation costs, repair costs or replacement costs.

2.1.2 What is meant by financial loss?

Financial loss may either be out-of-pocket loss or loss of business. Out-of-pocket financial loss is for example the costs of removing products and installing replacements after damage. Loss of business is the financial disadvantage suffered by an injured party as a result of a damaging event (e.g. lost income as a result of renovations following property damage).

2.1.3 What is meant by personal injury?

If a person suffers physical injury, this is known as personal injury. For the purposes of this document, the coverage of personal injury means the direct medical costs incurred as a result of the injury.

3. What is not covered?

Costs related to the damages incurred such as a result of:

- Non-compliance with the operating parameters defined and specified by aquatherm as found in aquatherm's technical documents. In cases of doubt, contact your local aquatherm manufacturer's rep. Exceptions must be provided for, in writing, by a member of aquatherm's engineering team.
- Non-compliance with the installation guidelines as set out in the aquatherm Catalogue, with emphasis to the required installation of aquatherm propriety clipping or other compatible with aquatherm piping.
- Non-compliance with respective National Plumbing Standards and Regulations.
- Joints which were not made in accordance with the aquatherm guidelines, including but not limited to: improper fusion technique, use of contaminated materials or tools, use of faulty or unsuitable tools, use of damaged materials or tools, or any connection made by an installer without sound knowledge of the aquatherm connection techniques and their processes.
- Improperly assembled connections to other pipeline systems and/or components (threads, flanges, stubs, mechanical joints not intended for use with aquatherm PP piping etc.).
- All sealing elements used in the product lines manufactured by aquatherm.
- Tools and accessories sold by aquatherm GmbH are covered for the warranty period by law under the statutory warranty provisions.
- Systems with defective pipeline sections or fittings that were not subjected to the aquatherm pressure test or alternative testing approved by aquatherm prior to start-up.
- Damage to our products caused by incorrect handling after the material has left aquatherm's possession.
- Damage caused or exacerbated by copper in the water resulting from erosion/corrosion or other degradation of copper components in a domestic hot water recirculating system.
- Time delay, caused by incorrect planning, delivery problems and/or incorrect orders.
- Damage caused by entrained air, cavitation and pressure fluctuations.

Note: This list only includes the most prominent examples. Other circumstances, which compromise the integrity of the products, may also jeopardize the coverage.



aquatherm

state of the pipe

EXPLANATORY COMMENTS ON THE AQUATHERM GMBH WARRANTY

4. How is the amount of compensation under the aquatherm warranty determined?

In the event of a material failure, samples of the damaged/faulty product are collected by the national aquatherm partner to forward them to aquatherm GmbH for examination and analysis. Working in collaboration with the injured party, aquatherm will identify the cause of the damage, and call in external bodies (test institutes, laboratories, assessors, etc.) as needed. If the damage has been caused by a material and/or manufacturing defect or by aquatherm's consulting/engineering services, the underwriter shall quantify the compensation claim for damages. All expenditures associated with the damages for this claim must be verified/recorded in detail and in a verifiable format as a required measure.

5. How much is the maximum coverage?

For the first 5 years of the warranty period, property damage, personal injury and financial loss is covered for the sum of €20 million per insurance claim. Total coverage for all claims made in a year is a maximum of €40 million. For years 6-10 of the warranty period, these coverage amounts are €7.5 and €15 million respectively.

6. Why is the coverage stated in Euro?

The insured manufacturer, aquatherm, as well as the insurer, are both based in the EU, so that their agreements are issued in Euros (€). Since exchange rates fluctuate, the exchange rate current on the date of compensation shall apply.

7. What is the channel of communication for notifying claims under warranty and making inquiries about them?

Warranty claims have to be made to aquatherm via the national aquatherm GmbH partners. Information about the progress of the claim will only be released by the aquatherm partner or aquatherm GmbH.

8. Legal note

If a discrepancy or conflict arises between this document and the underlying insurance policy, the latter shall in all cases prevail.

If a discrepancy or conflict arises between this translated document and the German document, the German document shall in all cases prevail.

9. Information about avoiding damage

I) **Manufacture under certified quality level**

As a trusted manufacturer, aquatherm works to a certified quality standard (ISO 9001); constant internal quality controls are part of the daily routine. In addition to this, all employees are integrated into a quality assurance program. As a result of this, products failing to comply with our high standards are quickly identified and removed from our product range.

II) **Preventing damage caused by incorrect handling**

Our products must be handled conscientiously and carefully when they are delivered from our production plants. Experience shows that most damage is caused in transit, storage and/or when working on site. At this point we would draw close attention to the fact that correct handling contributes to maintaining the product quality.

III) **Work is to be carried out by qualified installers**

Installation defects are easy to avoid. Our training courses teach the correct techniques in detail for working with our products. In doing so, particular importance is attached to work being carried out attentively and with care. The work of installers trained by us or our aquatherm partners is much more reliable and carried out much more efficiently.

For a safe connection, we recommend using only aquatherm PP products in a piping system. Mixing with other PP piping systems should be avoided.

June 2020

aquatherm GmbH, Biggen 5, 57439 Attendorn, Germany

REFERENCES

The application pictures in this catalogue show the aquatherm blue pipe pipes as they were produced until March 2020. With the material change to fusiolen® PP-RCT, the pipes are now single-coloured blue.

aquatherm factory, Attendorf, Germany



aquatherm factory, Attendorf, Germany



CIO, Cologne, Germany



Ecolab, Monheim, Germany



Millerntor stadium, FC St. Pauli 1910 e.V., Hamburg, Germany

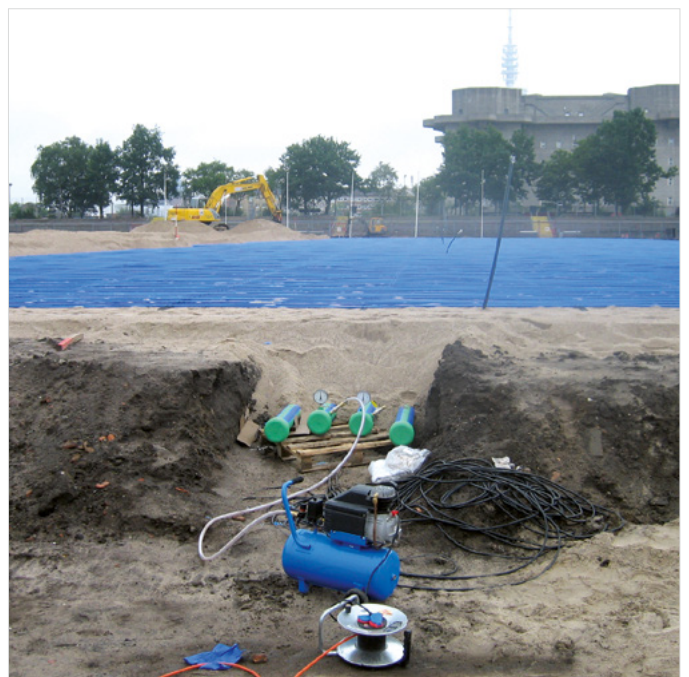

The Oval, Cyprus



Miraggio Thermal Spa, Kanistros, Greece



Hellenic Telecoms AG, Athens, Greece

Hotel Kalimera, Crete, Greece



Shopping Center, Seville, Spain



Photo: Grupo Lar

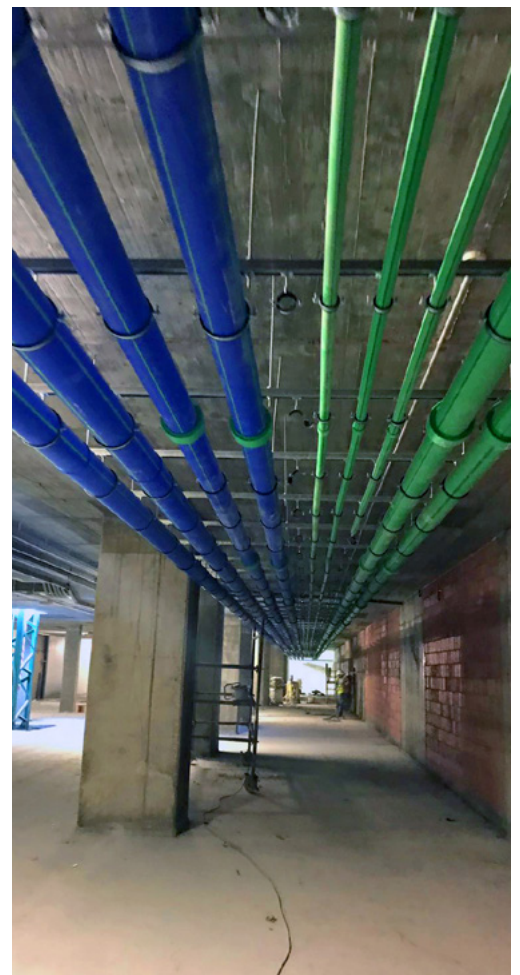

Riu Plaza de Espana, Madrid, Spain



Photo: Riu Hotels & Resorts

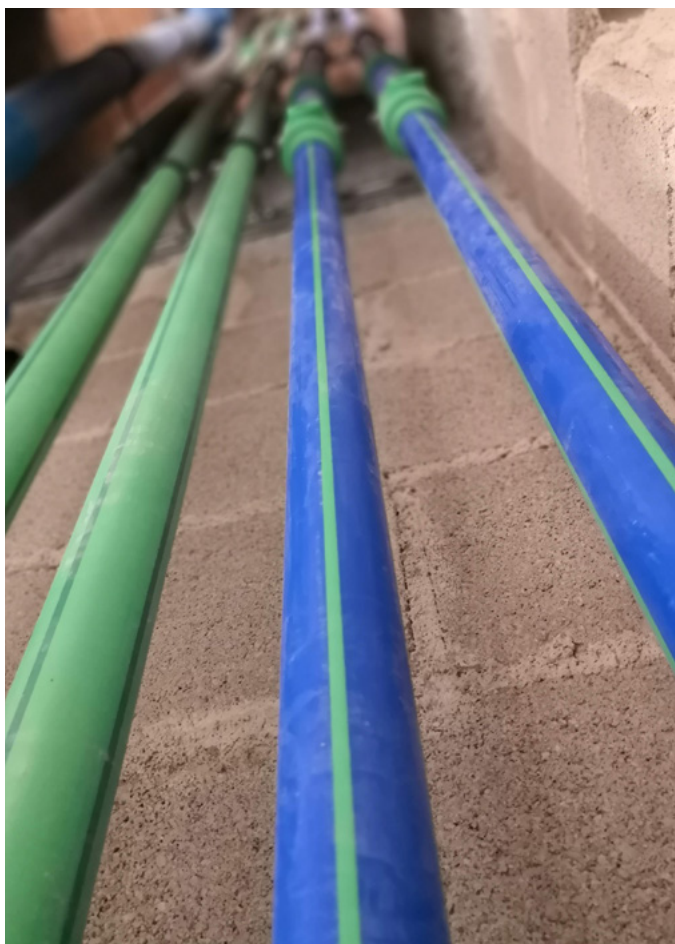

TCF Bank Stadion, Minneapolis (MN), USA



Seminole Hard Rock Hotel, Hollywood (FL), USA



LLNL, Livermore (CA), USA

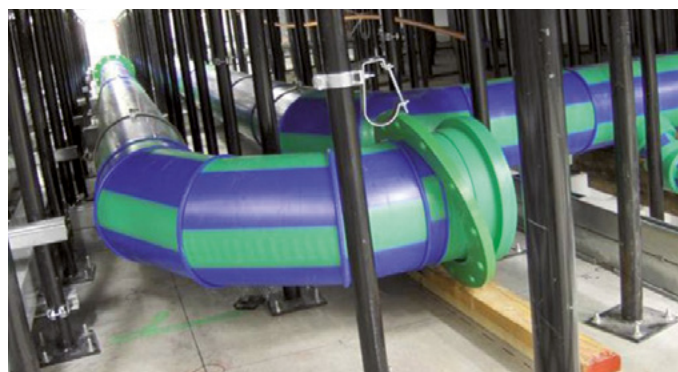

Neenah Paper, Stevens Point (WI), USA

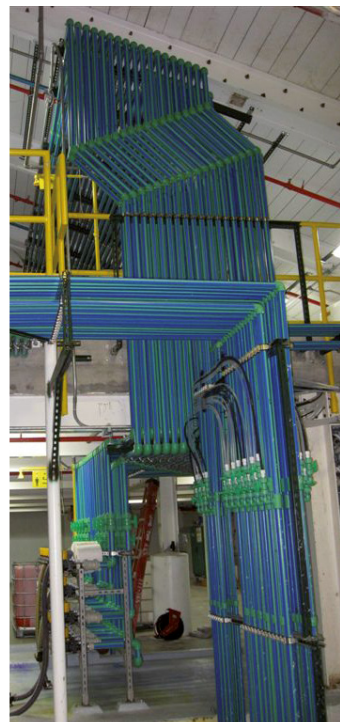
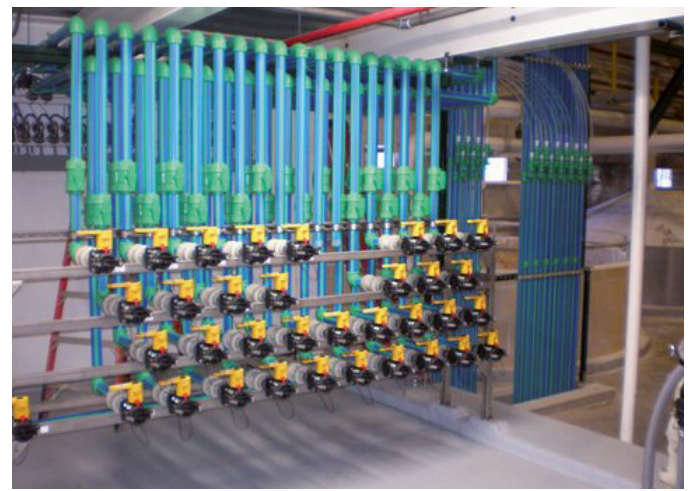

Daikin AC, Irvine (CA), USA



Epic Brewery, Denver (CO), USA



Hancock Medical, Bay St. Louis (MS) USA



Park Orchard Elementary School, Kent (WA), USA



Colorado State University, Fort Collins (CO), USA



The Standard Building, Cleveland (OH), USA



Old Dominion University, Norfolk (VA), USA



One-Six Multi-Family Residence, Calgary (AB), Canada

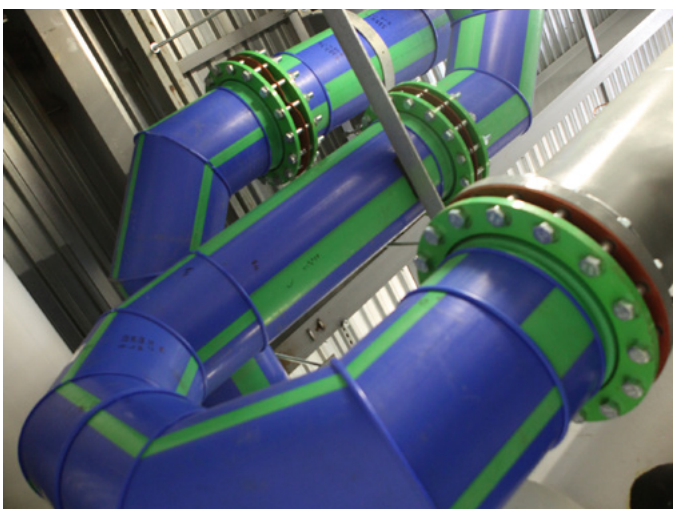

Flex Tower, Ras Al Khaimah, UAE



Al Sayegh Tower, Sharjah, UAE

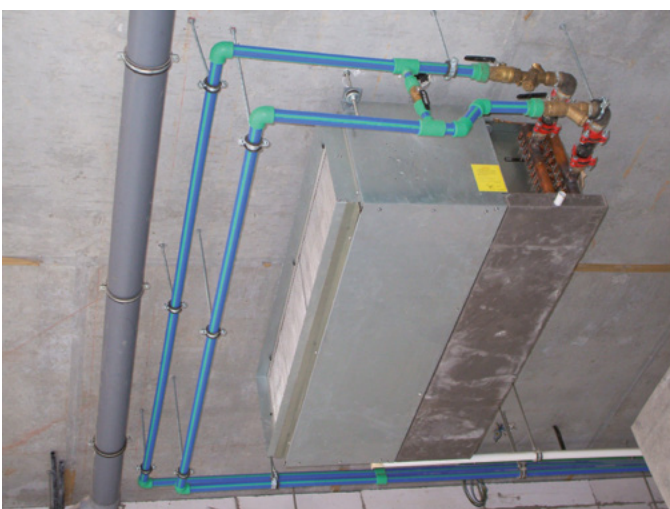

TRANSPORT AND STORAGE

aquatherm polypropylene pipes may be stored outside at any temperature. A solid base for the pipe is very important to avoid a deformation of the pipes while in transport and storage.

At temperatures below 0 °C it is possible to damage the pipes through strong impacts. The material has to be treated with caution at low temperatures.

In spite of its high resistance aquatherm pipes should be treated with care.

UV-radiation has effects on all high polymer plastics. Do not store permanently outdoor.

The maximum permissible storage time outdoors is 6 months.



TABLE OF CONTENTS

- aquatherm blue pipe** pipes
- aquatherm prefabrication
- Fastening material
- Fittings
- Weld-in saddles
- Weld-on saddles
- Flange adapter
- Threaded connections & accessoires
- Transition piece
- Screwed connections & counter parts
- Distributors
- Valves & accessoires
- Cutting tools & welding devices
- Welding machines & welding jig
- Butt welding machines & electrofusion device
- Peeling tools
- Saddle welding tools
- Drills & saddle peeling tool
- Hot tapping tool & accessoires

TERMS AND CONDITIONS

Important note regarding our sales, warranty and delivery conditions:

Our sales and delivery conditions (issue: 2014) as well as the contact details of our technical sales department and our representatives can be found on our website www.aquatherm.de.

Errors, misprints and technical modifications reserved. With the appearance of this catalogue all previous issues become void.

Современные
решения
**ИНЖЕНЕРНЫХ
СИСТЕМ**

Многолетний опыт работы на рынке

«Группа Компаний «Агпайп» — работая на рынке инженерных систем с 2007 года, специалисты накопили колоссальный опыт, обеспечивший возможность отобрать наиболее качественные и современные решения, которые были реализованы на более чем 5 000 объектах.

Наши возможности обеспечивают оперативное предоставление полного комплекса услуг по техническому сопровождению проекта и поставке даже в самых отдаленных уголках России и ЕАЭС.



Быстро

Центральный склад в московском регионе вмещает более 8000 км труб, 5 000 000 фитингов, 10 000 000 крепежных элементов и 500 километров профильных систем не снижаемого остатка на площади более 8000 кв. м.



Качественно

Высококачественные решения, подобранные экспертами компании, благодаря многолетнему опыту работы на российском рынке.



С поддержкой

Техническая поддержка оказывается специалистами компании с момента проектирования до ввода в эксплуатацию.

Области применения

Используя опыт специалистов нашей компании и решения лидирующих на мировом рынке брендов, предлагаемая концепция обеспечивает полное покрытие потребностей во внутренних трубопроводных и крепежных системах для любых типов зданий.

	ABC-PEX PIPE SYSTEM	aquatherm green pipe	aquatherm blue pipe	aquatherm red pipe	ET	OSS+ DRAIN+	CHX МВРО
Питьевое водоснабжение	●	●					●
Отопление*	●		●				●
Техническое водоснабжение			●				●
Хозяйственно-бытовая канализация					●		●
Ливневая канализация					●	●	●
Теплоснабжение \ Холодоснабжение			●				●
Вентиляция \ Кондиционирование			●				●
Пожаротушение				●			●
Судостроение		●	●	●	●		●
Системы сжатого воздуха			●				●
Транспортировка химических сред**			●				●
Обогрев \ охлаждение поверхностей	●		●				●
Геотермальные установки			●				●
Бассейновое оборудование		●	●		●		●

*При температуре не более 95 °С

**Согласно таблице химической стойкости каталога aquatherm



Management
System
ISO 9001:2015
ISO 14001:2015
ISO 50001:2011
www.tuv.com
ID 0091005348

aquatherm GmbH

Biggen 5 | 57439 Attendorn | Tel.: +49 2722 950 0

info@aquatherm.de | www.aquatherm.de

Order-No.: 9900000048
Edition: 01.2022

aquatherm blue pipe - Pipe system made of polypropylene For heating and cooling and various industrial applications