



aquatherm black system

Surface heating and cooling system

Applications: Ceiling, wall, floor



Официальный представитель завода
Группа Компаний Агпайп
☎ www.agpipe.ru
☎ +7(495)928-0008
✉ info@agpipe.ru



aquatherm

state of the pipe



CONTENTS

Service	4-5	Underfloor heating	93
System		Technical grid	94
		Shower and mirror	95
› Heating and cooling with aquatherm black system	6	Connection technology	96
› General		› Part 1: Welding	97
› Advantages		› Part 2: Push-fit connection	99
› Material		› Alternative fixings	101
› High-performance modules for cooling ceilings	8	Control	
› Applications	12	› Control methods	102
› System technology aquatherm black system	14	Planning and design	
› Comparison convection and radiation heat		› Heating and cooling	109
› Heating and cooling visualisation (metal panel ceiling)	16	› Pressure loss diagrams	112
› Heating and cooling visualisation (plastered wall)	18	Start-up and test records	
› Surface temperatures		› Start-up	113
› Utility space		› Flushing, filling and venting	
› Conduits and cables		› Leak test	
› Expansion joint		› Functional heating	
References		› Test records	115
› ITG Trade centre, Röttenbach	20	› Functional test for wet installed surface heating and/or surface heating and cooling systems (for wall and ceiling)	
› 2T Climbing and bouldering hall, Lindlar	21	› Functional test for dry installed surface heating and cooling systems	
› Consulting house, Moers	22	› Leak test of surface heatings and surface coolings	
› Huf City Living, Montabauer	22	Warranty	118
› DWFB, Attendorn	23	Product list	
› SHB, Munich	24	› Product list	121
› Mennekes, Kirchhundem	25		
› Hanse Hotel, Attendorn	26		
› AXA, Antwerp (Belgium)	27		
› Sky Office, Zagreb (Croatia)	28		
› Sanitär Heinze, Rosenheim	29		
› Giusto Basilico, Cogoletto (Italy)	30		
› Zuber Beton, Crailsheim	31		
Connection systems & performance data			
CEILING			
› Ceiling system with metal substructure and planking with building boards	33		
› Ceiling system with wooden substructure and planking with building boards	37		
› Ceiling system with insertion plates made of gypsum plasterboard or mineral fibre	43		
› Ceiling system plastered	48		
› Metal panel ceiling as clamping system	52		
› Metal panel ceiling as strip grid system	59		
› Ceiling system with metal insertion plates	63		
› Thermal active ceiling sail	67		
› Free convection	71		
WALL			
› Wall system with metal stud wall and planking with building boards	78		
› Wall system with wooden stud wall and planking with building boards	82		
› Wall system with wooden substructure and planking with building boards	85		
› Wall system plastered	89		

SERVICE

TECHNICAL HOTLINE

+49 2722 950 200

info@aquatherm.de www.aquatherm.de



Headquarters Attendorn

aquatherm GmbH
Biggen 5
D-57439 Attendorn
Phone: +49 2722 950 0



Subsidiary Radeberg

aquatherm GmbH
Wilhelm-Rönsch-Str. 4
D-01454 Radeberg
Phone: +49 3528 4362 0



Technical sales

The aquatherm application engineers are on the move all over Germany every day to support you on-site or in your workshop.

A list of our worldwide trade partners is available in the service section on our website www.aquatherm.de.



Training

We regularly offer specialist seminars and information events at our training centre in Attendorn. We also provide trainings at guild associations and specialist lectures at specialist wholesalers.

Trade fairs

aquatherm exhibits at all major sanitation and HVAC trade fairs in Germany and abroad. For more information please see our trade show calendar in the service section on www.aquatherm.de.

Certifications in accordance with ISO 9001, ISO 14001 & ISO 50001

Since 1996 aquatherm fulfills the requirements of the quality management system according to DIN ISO 9001. Our environmental management system is also certified to ISO 14001, as is our energy management system to ISO 50001.

This is a great achievement and represents another step towards strengthening our competitive position and meeting the high standards and responsibility to customers, partners and the environment.



Management System
ISO 9001:2015
ISO 14001:2015
ISO 50001:2011

www.tuv.com
ID 0091005348



Laboratory

From testing of granulate properties to permanent process monitoring: Only perfect goods have the chance to leave aquatherm.



Software service

The aquatherm software service provides Datanorm files, BIM-compatible files, an independent graphical configuration program (liNear) as well as the appropriate training on site.



Brochures and more

No matter if brochures, catalogues or product lists: everything is developed in our in-house advertising department. All documents can be downloaded as PDF from our website www.aquatherm.de. For printed copies just send an e-mail to infoservice@aquatherm.de.

SERVICE



Heating and cooling with aquatherm black system

An individual's physical well-being directly depends on the basic environmental conditions of the surroundings. Working efficiency decreases with increasing temperature, the costs increase with every cooling degree.

Incorrect controlled room temperature, noise interference or draught are responsible for inefficient room conditions and therefore unsatisfactory performances.

In offices, commercial premises, meeting rooms, etc., aquatherm pipe grids have become increasingly more popular for heating and cooling of ceilings and walls. The ingenious aquatherm black system creates pleasant room climate without noise and draughts.

Various control components for individual room control including automatic switching from heating to cooling operation complete the system.

aquatherm black system – due to its small sizes – can be laid tight below the plaster layer or the plasterboard.

The construction thickness including distributors, mounting rail and connections amounts to only 24.5 mm. The pipe grids have rectangular distributors, which are arranged mutually.

This allows an easy connection e.g. according to the reverse return principle (Tichelmann).

The aquatherm black system can be installed on metal panels of suspended ceilings and on plasterboards made of drywall or fibre gypsum. Even the embedding in plaster layer or the installation in C-studs with plasterboards is not a problem. The low weight of only 4.1 kg/m² (incl. water filling) does not affect the design of the ceiling element construction. The ceiling elements should include minimum 30 mm fibre glass insulation. Depending on their design, the pipe grids are connected by thermal welding or with push-fit coupling, respectively connected to the cooling and heating water circuits.

Advantages:

- *No draughts, thus highest climate comfort*
- *Noiseless*
- *No additional dust exposure*
- *Simple control technique*
- *Thermal properties of the building are enhanced*
- *Well suited for retrofitting*
- *Quick installation thanks to high prefabrication degree*
- *Even temperature distribution*
- *Safe connection techniques by thermal fusion/Push-fit connection for ceiling elements*
- *Oxygen-tight*
- *Low installation height*
- *Architectural freedom*
- *Energy efficient during operation*
- *Suitable as plaster base for ceiling suspension*

The mode of operation of the aquatherm black system, installed as a heating or cooling ceiling, is that the surface temperature is kept a few degrees below or above the room temperature. By radiation exchange with the ceiling, the temperatures of the room surface and furnishings change. The total power is achieved by 2/3 radiation and 1/3 convection.

The output is determined by the difference between room temperature and average surface temperature. High difference = high heat transfer.

aquatherm black system matches exactly the size of metal cassettes. Active and inactive surfaces can be combined without visible differences. Retrofitting is possible at any time.



Heating and cooling grids oxygen-tight according to DIN4726

Material:

aquatherm black system is exclusively made from fusiolen® PP-R. The physical properties specially match the requirements of the heating and cooling sector.

The exceptionally good welding properties offer a maximum in security and durability. fusiolen® PP-R also provides high temperature and pressure resistance.

A permanent operating temperature of 70 °C is no problem. Normally, the aquatherm black system operates at substantially lower temperatures than conventional heating systems.

In conjunction with the aquatherm blue pipe system (made from fusiolen® PP-RCT) for climate, heating and industrial technology, aquatherm offers a complete solution for heating and cooling generators.

Material:	fusiolen® PP-R
Distributor/Collector in square design:	24/14 mm
Grid pipes in square design:	12/12 mm
Centre distance of grid pipes:	40 mm
Lengths:	400-1000 mm (in 100 mm steps) 1000-2000 mm (in 200 mm steps) 2000-2500 mm (in 250 mm steps) Special sizes and lengths up to 5000 mm on request!
Widths:	240 - 1000 mm (in 40 mm steps)
Exchange area:	1,0 m ² /m ²
Water volume:	2,0 ltr./m ²
Weight (incl. water):	4,1 kg/m ²

Allowed permanent operating pressure

4 bar

at max. 70° C

Differing working conditions on demand.





HIGH-PERFORMANCE MODULES FOR COOLING CEILINGS

aquatherm black system high-performance modules combine aquatherm's proven heating and cooling grids with heat conducting plates and – depending on the selected product – with aluminium carrier plates. The modules take advantage of the pressure drop and fluidics of the grids and the very good thermal conductivity of the aluminium. Full-surface bonding guarantees easy and quick installation. And thanks to reduced-connection technology, assembly time is minimized and the cost per square metre of installed ceiling is decreased.

The aquatherm black system high-performance modules can be used as a heating and cooling system. Their surface temperature is only a few degrees above or below the desired room temperature. They are ideal for heating systems using renewable energies, such as heat pumps. The uniform heat or cold transmission by means of radiation ensures increased comfort. In addition, there are no draughts created or dust raised, as can be the case with blower-driven heating and cooling systems.

The aquatherm black system high-performance modules are available in three different variants:

- Plug & Play: grids with heat conducting plates and carrier plate
- WLT: grids with heat conducting plates
- Drywall-HLM: grids with heat conducting plates and carrier plate

Advantages

- *High heating and cooling performance due to excellent transmission surface contact*
- *Short assembly times thanks to pre-fabricated, self-adhesive modules*
- *Soundless and invisible*
- *No draughts or airborne dust blowing around*
- *Ideally suited for use with heat pump and condensing boiler technology due to low flow and return temperatures*
- *High sound absorption in metal ceiling panels with micro perforation or in perforated plasterboard plates*
- *Retrofittable into existing metal ceiling systems*

APPLICATION

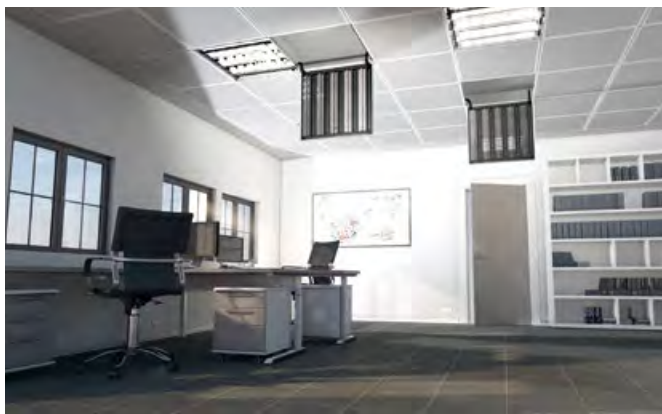

METAL PANEL CEILING AS CLAMPING SYSTEM



THERMAL ACTIVE METAL CEILING SAIL



METAL PANEL CEILING AS STRIP GRID SYSTEM



CEILING SYSTEM WITH METAL SUBSTRUCTURE AND PLANKING WITH BUILDING BOARDS

Performance values of ceiling system high-performance modules. Standard **cooling** performance according to DIN EN 14240:2004-04

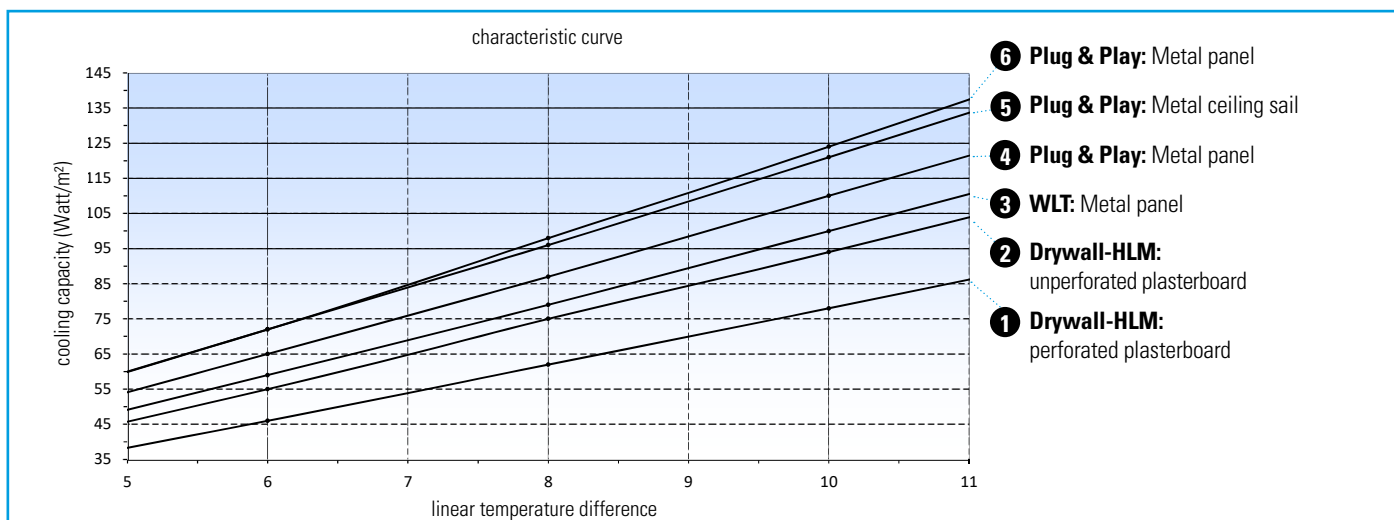

- 6 Plug & Play:** Metal panel
- 5 Plug & Play:** Metal ceiling sail
- 4 Plug & Play:** Metal panel
- 3 WLT:** Metal panel
- 2 Drywall-HLM:** unperforated plasterboard
- 1 Drywall-HLM:** perforated plasterboard

Calculation example for: Flow temperature 15° C / Return temperature 17° C

Linear temperature difference K		6	8	10
Room temperature °C		22	24	26
1 Drywall-HLM	perforated plasterboard with graphite content 10 mm 8/18R	46	62	78
2 Drywall-HLM	unperforated plasterboard with high graphite content 10 mm	55	75	94
3 WLT	Metal panel, with acoustic fleece	59	79	100
4 Plug & Play	Metal panel, with acoustic fleece	65	87	110
5 Plug & Play	Metal ceiling sail, with acoustic fleece	72	96	121
6 Plug & Play	Metal panel, without acoustic fleece	72	98	124

SYSTEM PLUG & PLAY**Application: metal panel**

The Plug & Play high-performance modules consist of grid, heat conducting plates and aluminium carrier plate.

They are either inserted mechanically into the metal panel at factory and delivered to the site as complete package (system „activated“) or they are activated directly on site by manually pushing the modules into the existing metal panel (system „solo“). Retrofitting is also possible.

Panel size [mm]	Total module width [mm]	Associated grid width [mm]
> 300 bis ≤ 400	300	240
> 400 bis ≤ 500	400	360
> 500 bis ≤ 600	500	400
> 600 bis ≤ 700	600	520
> 700 bis ≤ 900	700	600
> 900	900	800

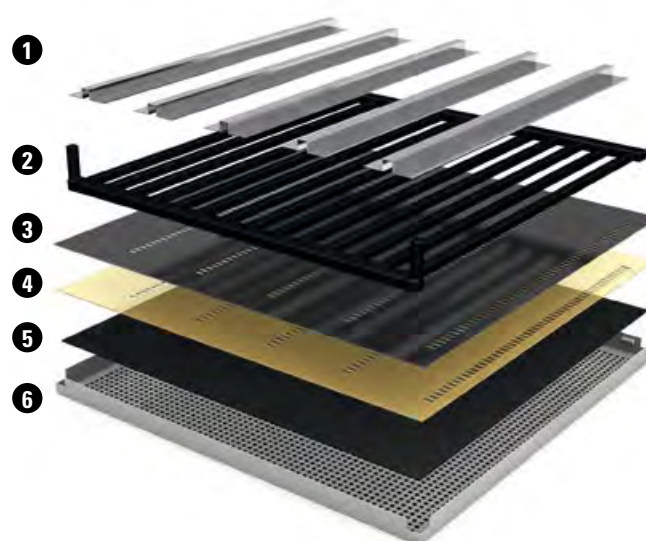

1. Heat conducting plates
2. Heating/cooling grid
3. Carrier plate (self-adhesive)
4. Protective film (removed before bonding)
5. Acoustic fleece
6. Metal panel

SYSTEM WLT**Application: metal panel**

The grids are installed in the factory with aluminium heat conducting plates in metal panels. The activated metal panels are delivered directly to the site. The finished metal panel elements only have to be hooked into the substructure and hydraulically connected.

Grid width [mm]	Total module width [mm]
240	265
280	305
320	345
360	385
400	425
480	505
520	545
560	585
600	625
680	705
800	825
1000	1025



1. Heat conducting plates
2. Heating/cooling grid
3. Acoustic fleece
4. Metal panel

SYSTEM DRYWALL-HLM

Application: drywall plasterboard ceilings

The aquatherm black system high-performance drywall-HLM modules consist of grid, heat conducting plates and aluminium carrier plate. For acoustic ceilings (perforated plasterboards ceilings), the aluminium carrier plate is perforated to ensure optimal sound absorption. The installation of the high-performance drywall-HLM modules is very easy: The modules are hooked into the supporting profiles of the substructure. Then the ceiling is covered with building boards. For this, e. g. plasterboards and perforated plasterboards with different thermal conductivities can be used.

Centre distance substructure [mm]	Total module width [mm]	Associated grid width [mm]
333	263	240
400	330	320
500	430	400



1. Heat conducting plates
2. Heating/cooling grid
3. Carrier plate (closed or perforated)

ARTICLE STRUCTURE

Available lengths: 600 up to 2500 mm

Graduation identical to aquatherm black system standard (see following page)

Special sizes and lengths up to 5.0 m on request!

System		Connection types	
Plug & Play	Solo (Installation on metal panel on site)	("43" xx xxx)	("44" xx xxx)
	Activated (Pressed directly onto metal panel ex works)	("45" xx xxx)	("46" xx xxx)
WLT		("31" xx xxx)	("32" xx xxx)
Drywall-HLM	Drywall with substructure Distance: 333 mm	("36" xx xxx)	("37" xx xxx)
	Drywall with substructure Distance: 400/500 mm	("38" xx xxx)	("39" xx xxx)

Composition of the article numbers:

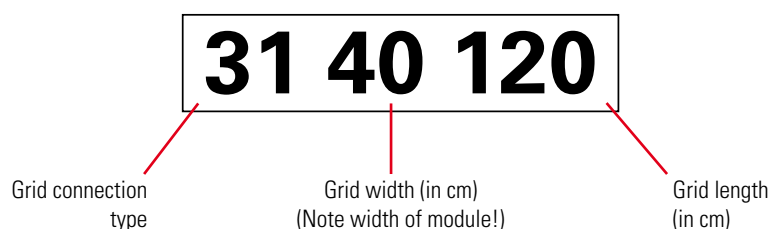

APPLICATIONS



1. Ceiling system with wooden substructure

The aquatherm black system heating/cooling grids are installed between the supporting profiles of the substructure. The ceiling is then boarded with plasterboard panels. Plasterboard of different thermal conductivities can be used. With an insulation carried out according to EnEV, aquatherm black system presents its advantages in new buildings and in housing extension. The radiant heat can be used optimally with a low flow temperature. Heat accumulation in the gable area belongs to the past.

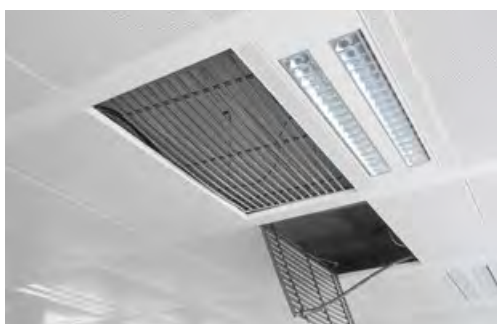

2. Metal panel ceiling

The grids for heating and cooling are placed in the metal panels. The contact of the grids with the panels ensures excellent power transfer. In offices or practices aquatherm black system provides draught-free cooling in the summer and pleasant warmth on cold days.



3. Wall system with metal substructure

The heating and cooling grids are installed in the drywall stud frame and then boarded with plasterboard panels. Applications are e.g. renovation measures in which a laying in the floor or ceiling is no longer possible or retrofitted walls for room partitioning.

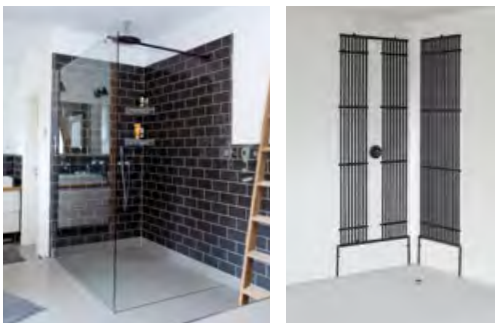

4. Use in the shower area

aquatherm black system grids provide cosy warmth in the shower area. Cold radiating tiles along with mould formation belong to the past. The individual adaptability to the shower size and the shower fitting enables installation in both new and old buildings. aquatherm black system can be connected and combined with the existing heating appliance or underfloor heating system.



5. Mirror heating and towel warmer

aquatherm black system installed behind a mirror prevents the mirror from fogging. Easy installation and different available sizes make it the ideal complement to the wall heating in the shower. aquatherm black system grids are also well suited as invisible towel warmers providing additional comfort.



6. Plastered wall and ceiling heating

The grids for heating and cooling are integrated right under the bare ceiling into the plaster layer. The grids and connected piping are attached to the ceiling. Plaster works are done according to general plastering guidelines. All commercially available gypsum, lime, cement and loamy clay are suited for it. The low installation height of the aquatherm black system and the loss-free heat emission through the enclosing material are perfect for generating natural and healthy heat.

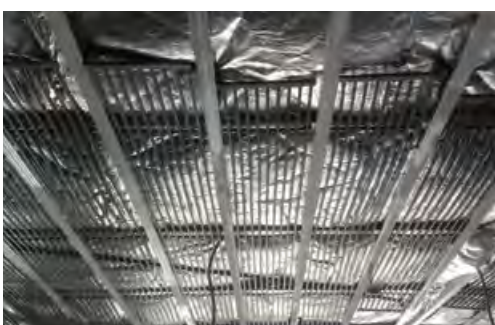

7. Ceiling system with metal substructure

The aquatherm black system heating/cooling grids are installed between the supporting profiles of the substructure. The ceiling is then boarded with plasterboard panels. Large areas in office and administration buildings as well as entrance and event halls can be heated and cooled with aquatherm black system. No matter if a large-scale project or a single-family house, the retrofit installation during renovation or maintenance is fast, easy and clean. The low construction height reduces the room height only minimally and creates more usable living space by the omission of radiators.



8. Underfloor heating

aquatherm black system also scores as underfloor heating. There is no dust swirling-up as usual with radiators. The uniform surface heat prevents the growth of house dust mites and mould fungus formation. Whether open screed in workshops, production halls or garages, tiles, parquet and laminate in apartments and houses, the floor construction can be carried out individually and varied.

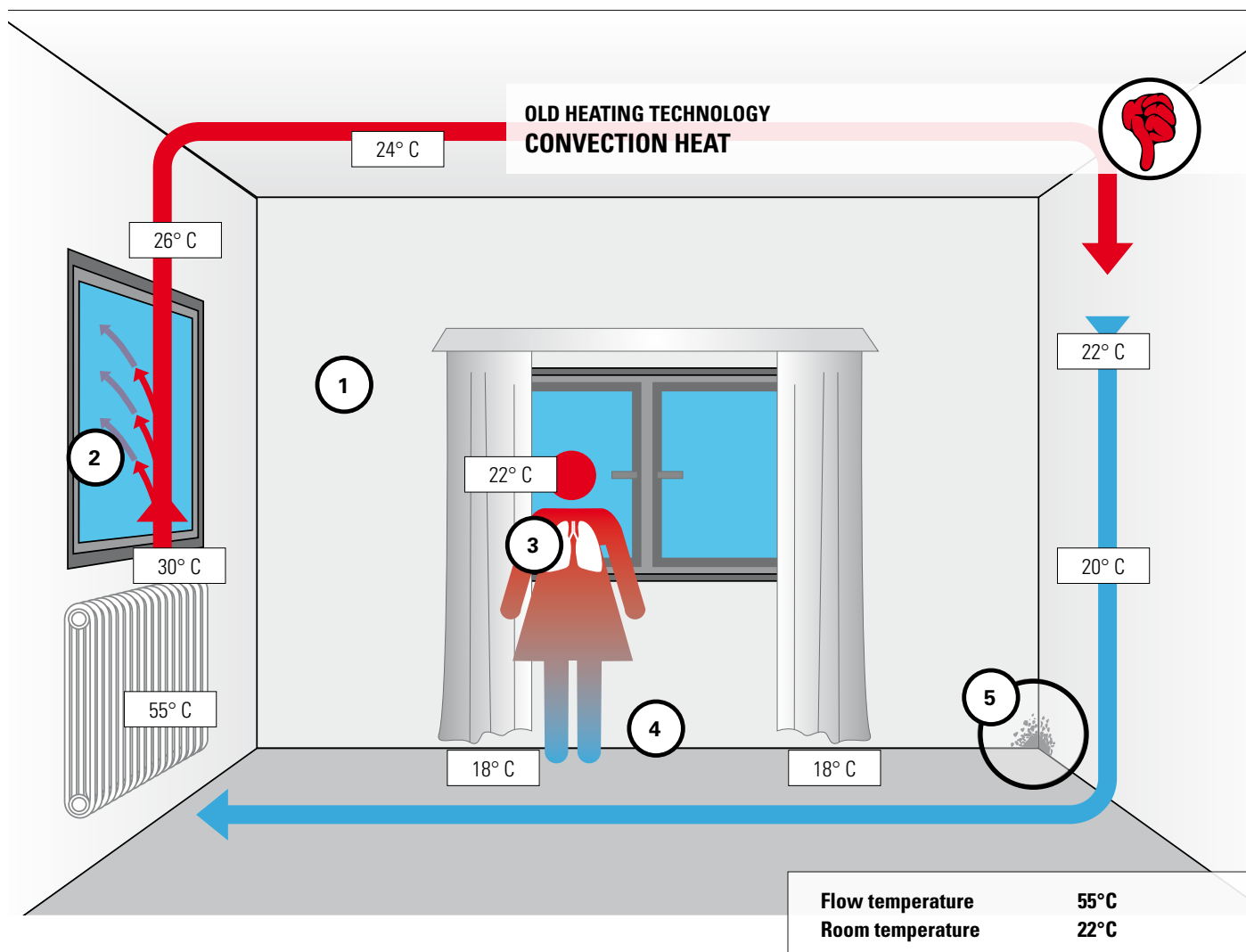

Convection heating with radiator

- ① **Energy loss 1:**
A high air temperature of at least 22°C is required to heat a room with air. Air is a bad heat carrier; therefore the energy costs are high.
- ② **Energy loss 2:**
Even premium quality windows are the weak point of a house insulation and result in high energy losses. The air heats up the glass and the energy leaks when venting.
- ③ **Health risk:**
The air movement (warm air rises) decreases the sense of well-being, since asthmatic and allergic persons have a primary problem with raising dust. This dust mixes with our breathing air and can lead to enormous burdens of the organism. An increase of the room temperature requires a reduction of the air humidity. Mucous membranes will dry out. The natural filtration system (nose) will be affected.
- ④ **Discomfort:**
The feet remain cold as warm air rises up and is mainly in the upper area of a room. This creates a feeling of discomfort. As a result, the heating is adjusted to a higher level. The above effects will be increased.
- ⑤ **Mould formation:**
Cold air strokes the wall, water condenses and becomes a breeding ground for mould.

System technology aquatherm black system

Heating visualisation

The photos of the high-resolution thermal camera illustrate: aquatherm black system for ceiling heating evenly radiates heat in the room, ensures a holistic heat sensation and thus creates a comfortable room climate.

Example: Metal ceiling panel

Room temperature: 20 °C

Linear heating temperature: 32 °C

Radiation surface temperature: see screen sequence

Original metal ceiling panel

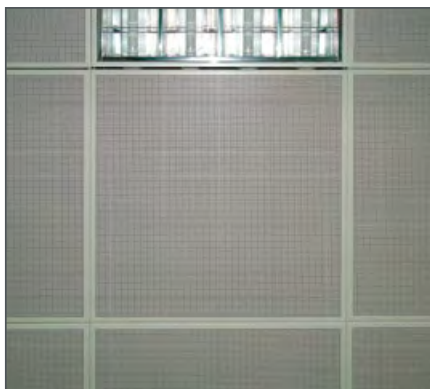

Start of heating

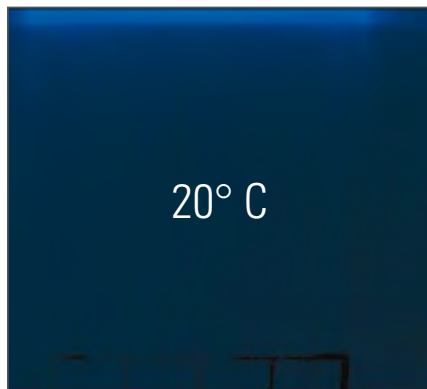

after 1 minute

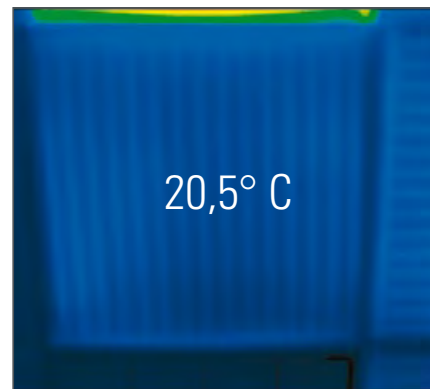

after 1,5 minutes

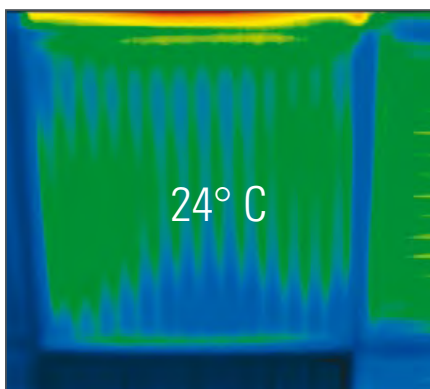

after 2 minutes

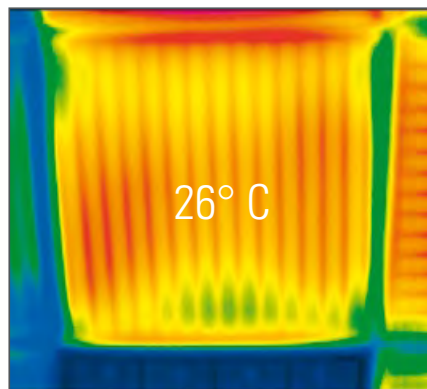

after 2,5 minutes

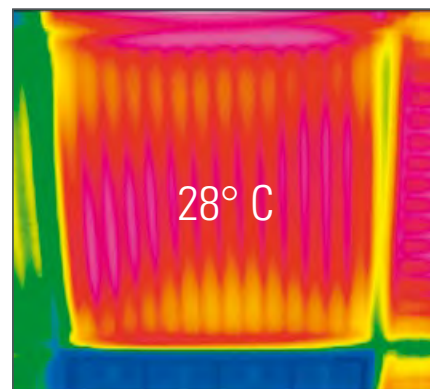

after 3 minutes

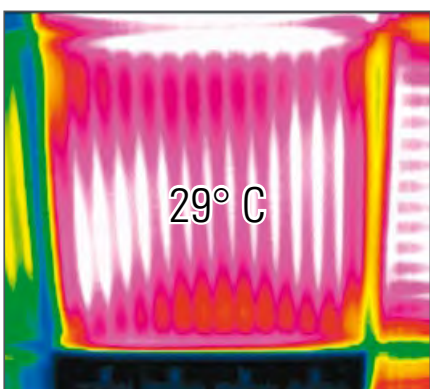

after 3,5 minutes

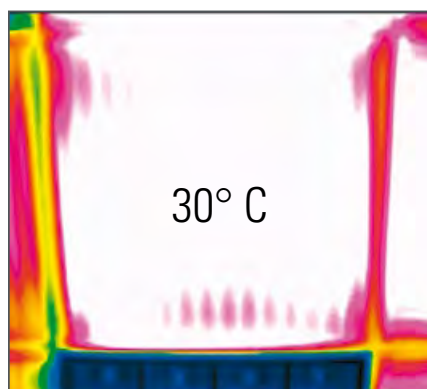

after 4 minutes

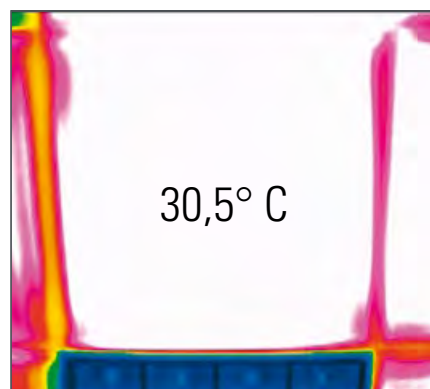

System technology aquatherm black system

Cooling visualisation

The thermal camera impressively demonstrates: aquatherm black system for cooling ceilings provides even cooling and does not only create a pleasant, but also a healthy room climate.

Example: Metal ceiling panel

Room temperature: 24 °C

Linear cooling temperature: 16 °C

Radiation surface temperature: see screen sequence

Original metal ceiling panel



after 1 minute

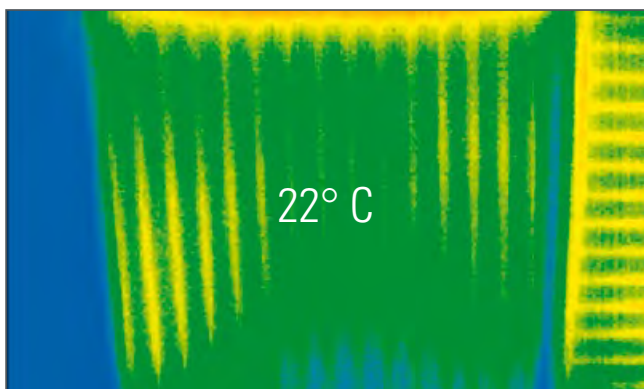

after 4 minutes

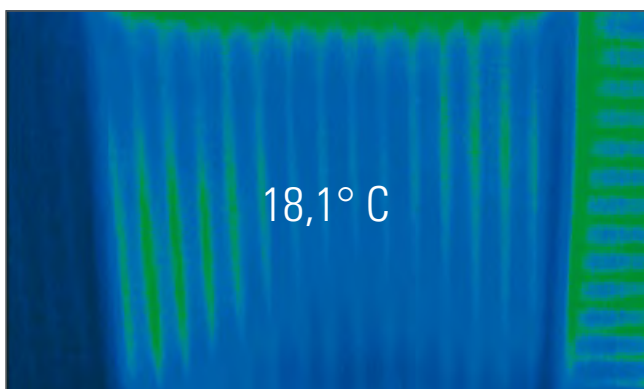

Start of cooling

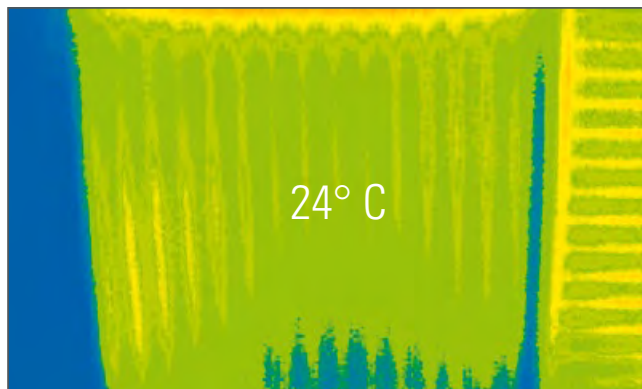

after 2 minutes

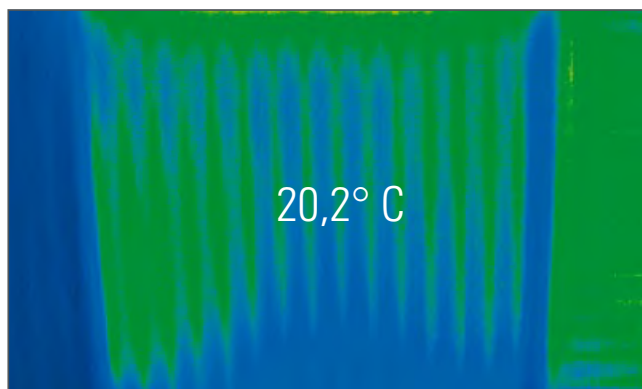

after 6 minutes

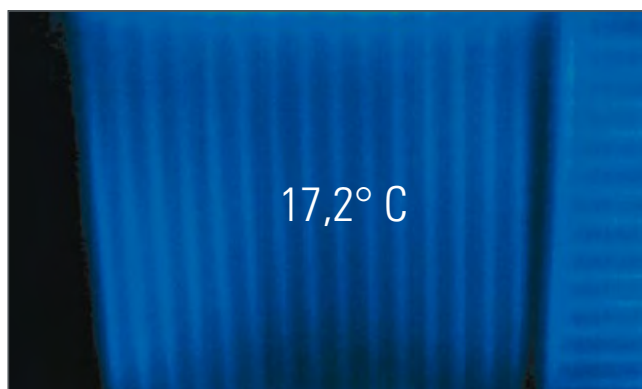

System technology aquatherm black system

Heating visualisation of grid with flow break

The photos of the high-resolution thermal camera reveal:
The aquatherm black system grid with flow break shows a perfect flow and grants an optimum heat distribution at the wall, on the underfloor heating or under the ceiling within a short time.

Example: Plastered wall

Room temperature: 20° C
Linear heating temperature: 35° C
Radiation surface temperature: see screen sequence

Start of heating

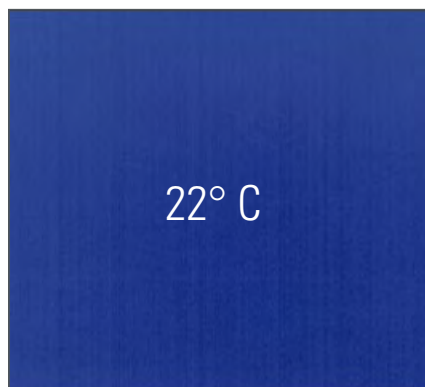

after 1 minute

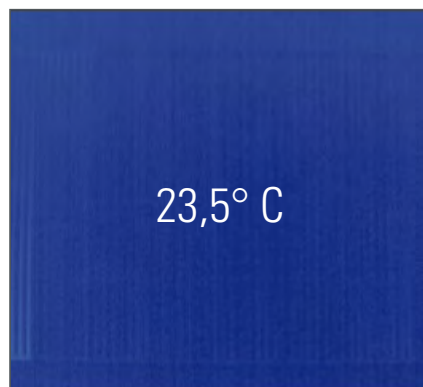

after 2 minutes

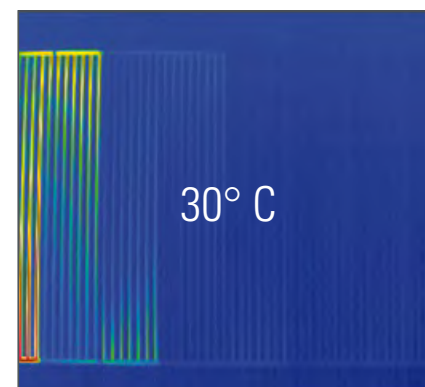

after 3 minutes

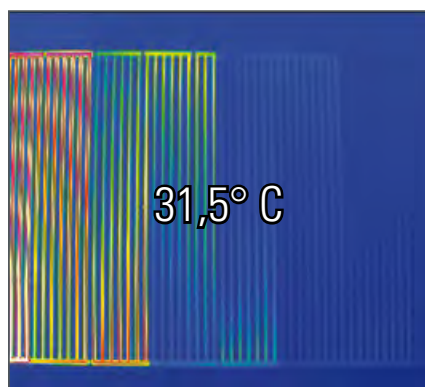

after 4 minutes

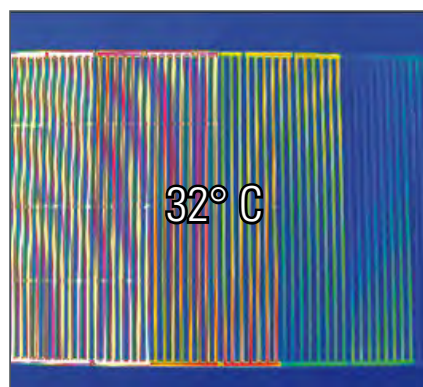

after 5 minutes

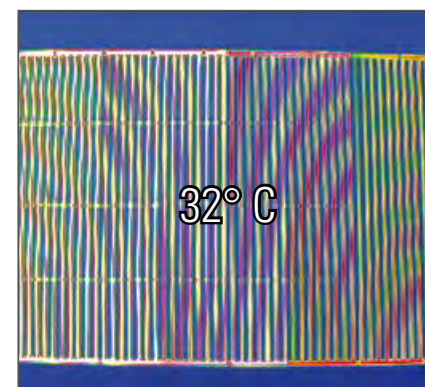

Surface temperatures

The surface temperatures are dependent on the heat efficiency of the wall heating. This also depends on the heat loss of the room/building and on the surface, which is available for the installation of the wall/ceiling heating.

In addition, the spacings of the heating pipe, the surface finishes and the design of the wall/ceiling heating cause a more or less ripple of the surface temperature.

That means, the temperature above the heating pipes is higher than in the intervals. Even surface temperatures are obtained by a close pipe spacing (40 mm/25 m pipe per m²) of the aquatherm black system.

The average surface temperature of wall/ceiling heating should be regulated for physiological reasons. In rooms with low dwelling time (e.g. baths, swimming pools, therapeutic areas) the surface temperature is limited to 35 °C and in rooms with long dwelling time (e.g. living rooms, day rooms, offices) it is limited to 30 °C.

Utility space

In the planning stage of wall heating design, the future use should be taken into consideration. When arranging the grids, personal and spatial needs can be considered. The placement of large furniture must be considered, while smaller furniture (e.g. desk, seat set and pictures) can be disregarded. Thus, the outside wall often remains as possible option.

Conduits and cables

Conduits and cables which are placed on the weight-bearing subsurface must be well fixed. They can be surface mounted or concealed behind the aquatherm black system.

Expansion joint

To accommodate length expansion of the wall and ceiling construction a suitable option for expansion to the near-by construction parts must be provided. The manufacturer's instructions of plaster or building boards must be observed.

CHAPTER REFERENCES

ITG TRADE CENTRE, RÖTTENBACH, GERMANY

Metal panel ceiling as clamping system, perforation Type 2516 with fleece – connection type 62



2T CLIMBING AND BOULDERING HALL, LINDLAR, GERMANY

Free convection with direct assembly – connection type 64

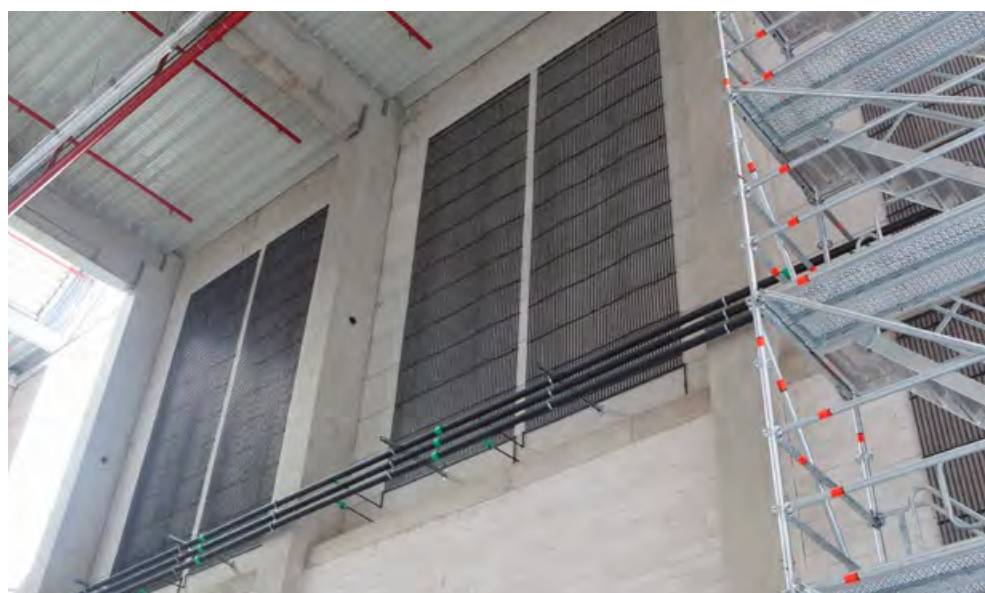
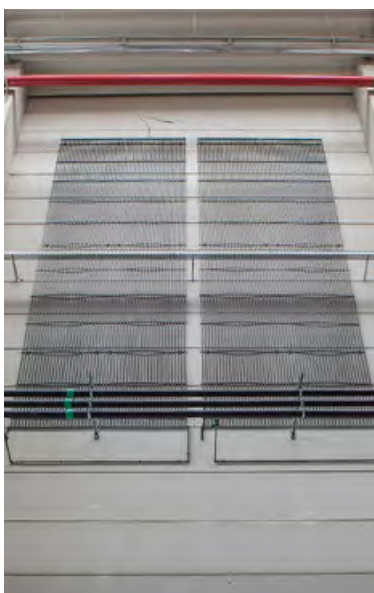
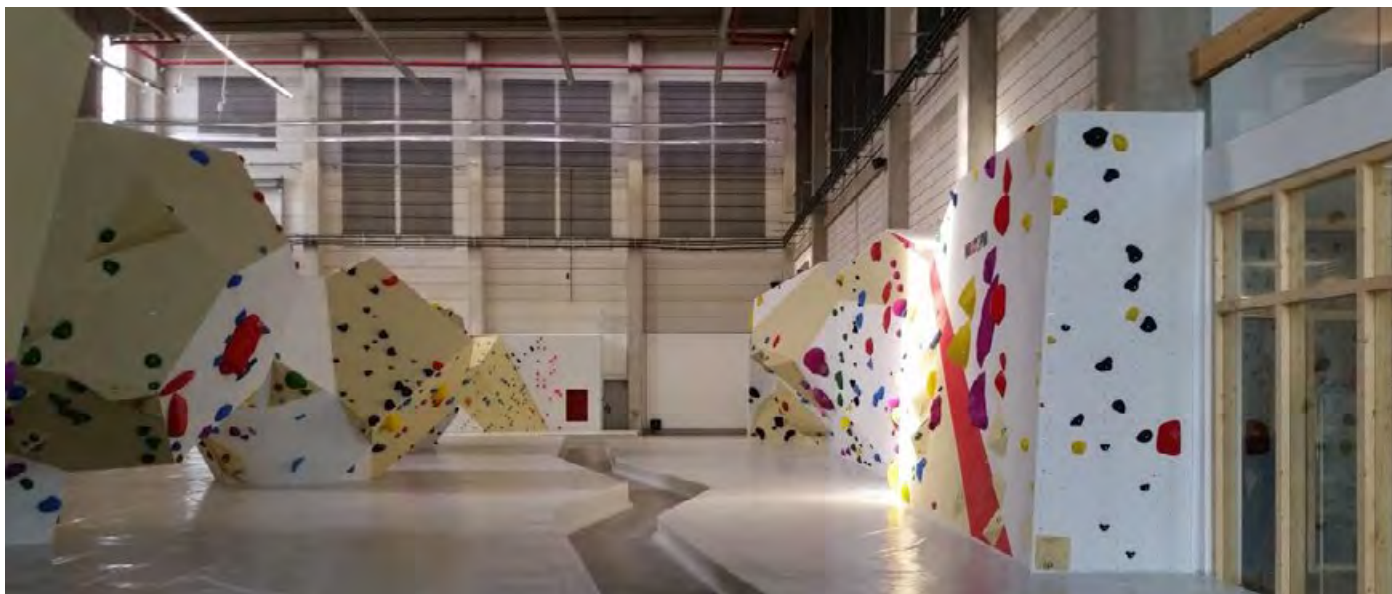

CONSULTING HOUSE, MOERS, GERMANY

Drywall ceiling with metal substructure and planking with acoustic panels made of plasterboard Thermoboard – connection type 62

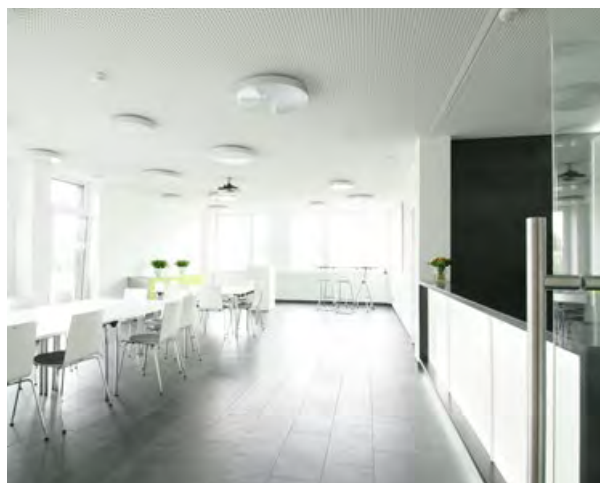

HUF CITY LIVING, MONTABOUR, GERMANY

Drywall ceiling with metal substructure and planking made of plasterboard Thermoboard – connection type 52 & 62

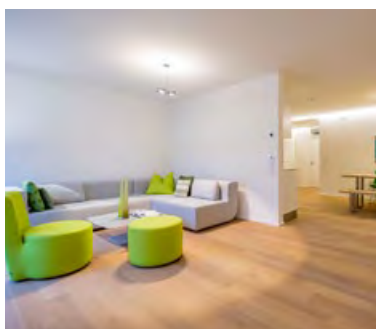

DWFB, ATTENDORN, GERMANY

Closed metal ceiling sail – connection type 62



SHB, MUNICH, GERMANY

Dry construction ceiling with metal substructure and planking made of plasterboard Thermoboard – connection type 52



MENNEKES, KIRCHHUNDEM, GERMANY

Metal ceiling sail in special format, perforation type 2516 with fleece – connection type 62



HANSE HOTEL, ATTENDORN, GERMANY

Ceiling system plastered – connection type 64

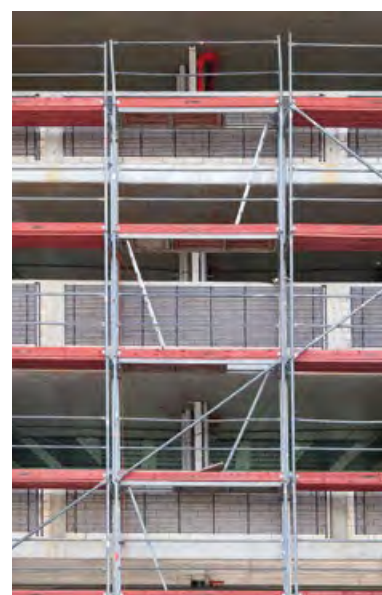
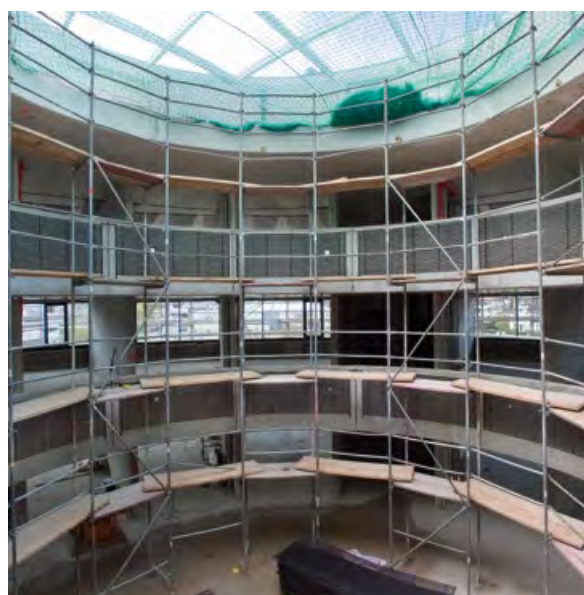

AXA, ANTWERP, BELGIUM

Metal panel ceiling as strip grid system, perforation Type 2516 with fleece – connection type 52

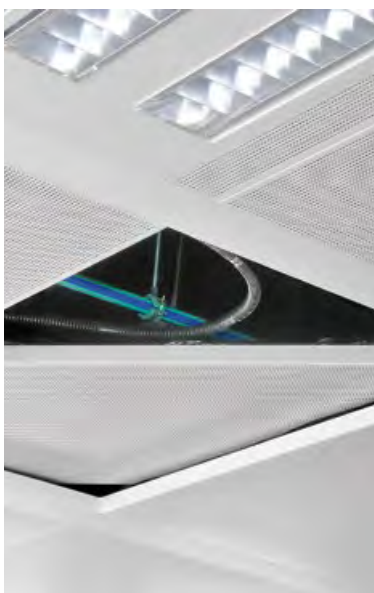

SKY OFFICE, ZAGREB, CROATIA

Dry construction ceiling with metal substructure and planking made of plasterboard Thermoboard – connection type 62

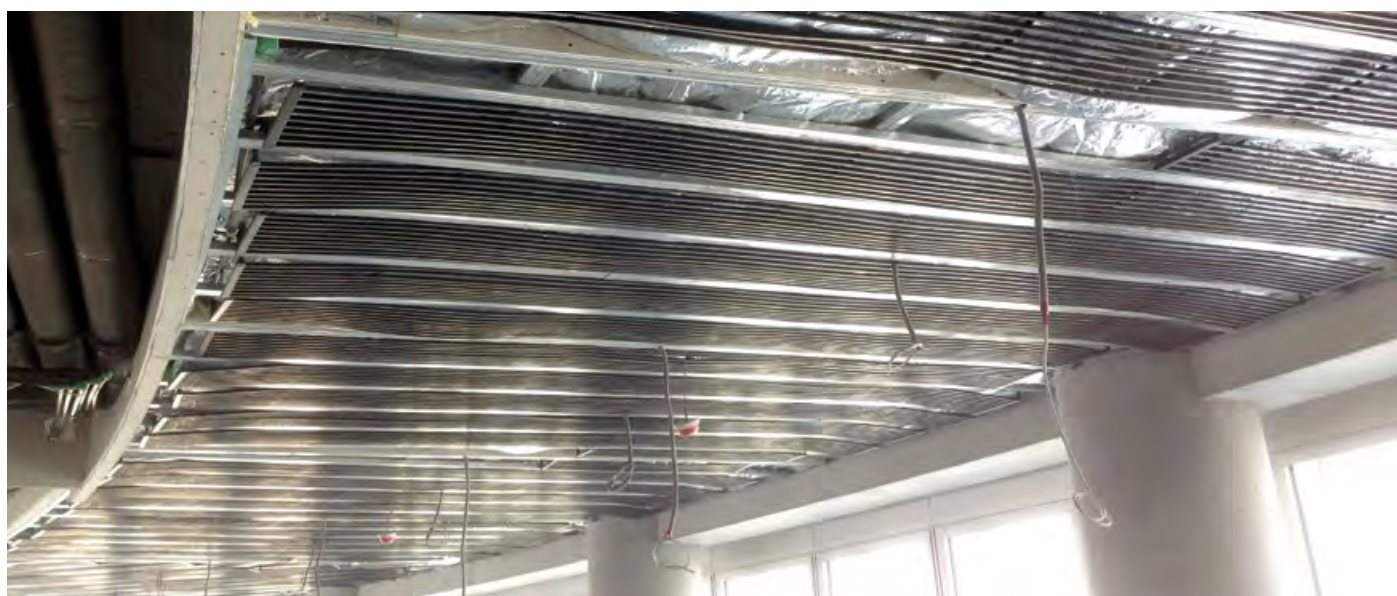

SANITÄR HEINZE, ROSENHEIM, GERMANY

Metal panel ceiling as clamping system, perforation Type 2516 with fleece – connection type 62



SPECIAL APPLICATION BASIL CULTIVATION**GIUSTO BASILICO, COGOLETO, ITALY**

aquatherm black system in hydroponic soil ensures optimal basil cultivation – connection type 64



FILIGREE CEILING – NEAR SURFACE, THERMAL ACTIVATION OF CEILING PANELS
ZUBER BETON GMBH, CRAILSHEIM, GERMANY

Near surface activation of precast concrete for an office building – connection type 64



CHAPTER

APPLICATION EXAMPLES

CEILING

Ceiling system with metal substructure and planking with building boards	Page 33
Ceiling system with wooden substructure and planking with building boards	Page 37
Ceiling system with insertion plates made of gypsum plasterboard or mineral fibre	Page 43
Ceiling system plastered	Page 48
Metal panel ceiling as clamping system	Page 52
Metal panel ceiling as strip grid system	Page 59
Ceiling system with metal insertion plates	Page 63
Thermal active ceiling sail	Page 67
Free convection	Page 71

WALL

Wall system with metal stud wall and planking with building boards	Page 78
Wall system with wooden stud wall and planking with building boards	Page 82
Wall system with wooden substructure and planking with building boards	Page 85
Wall system plastered	Page 89

UNDERFLOOR HEATING

Page 93

TECHNICAL GRID

Page 94

SHOWER AND MIRROR

Page 95



Ceiling system with metal substructure and planking with buildings boards

Description

The assembly of the aquatherm black system grids is simple: just between the supporting profiles of the metal substructure. Then the ceiling is covered with building boards. For this, e.g. buildings boards with made of plasterboard with different thermal conductivities can be used. The grids are available in different widths and lengths so that the ceiling can be individually covered.

Advantages

- High heating and cooling performance due to full activation of the ceiling surfaces
- Combination with centrally conditioned outside air is possible
- Ideally suited for use with heat pump and condensing boiler technology due to low flow and return temperatures
- High sound absorption in combination with perforated gypsum plasterboards
- Combination of thermally active and passive ceiling elements
- Installation in combination with various ceiling installation/substructures such as lights, fire detectors and ventilation components
- Attractive design and architectural freedom in the ceiling surfaces
- Rapid construction progress thanks to dry construction system

Sound absorption

Sound absorption describes the reduction of sound energy. By reflection of the waves at the room boundaries a diffuse sound field is created, in which the direct sound of the sound source is superimposed with reflecting sound components and effects from all directions with approximately the same intensity. If it is possible to reduce the reflections at the room boundaries, it gets quieter in the room. The absorption coefficient α indicates how large the absorbed part of the total incident sound is:

If $\alpha = 1$, the entire incident sound is absorbed, there is no longer any reflection.

If $\alpha = 0.5$, 50% of the sound energy is absorbed and 50% of the sound energy is reflected.

Acoustic values of a standard drywall ceiling

Frequency (Hz)	125	250	500	1000	2000	4000
α_p	0,55	0,70	0,70	0,70	0,60	0,60
Sound absorption coefficient for a drywall ceiling with proportional perforation of 15.5 %, type 8/18R						
Evaluation according to ISO 354 Practical sound absorption coefficient according to ISO 11654						
$\alpha_w = 0,70(L)$						
Sound absorption class C						

Ceiling system with metal substructure and planking with building boards - connection type 62

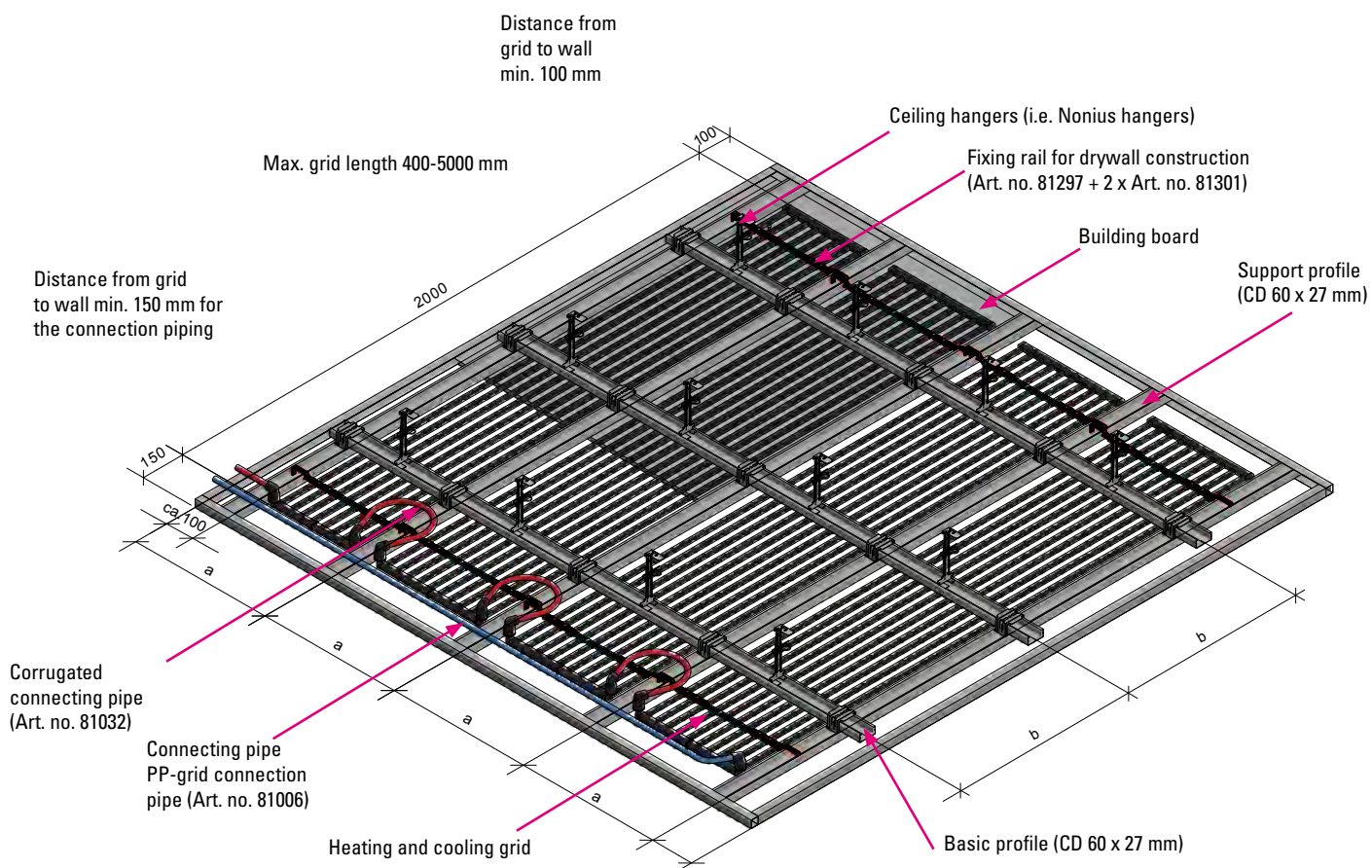

Ceiling system with metal substructure and planking with building boards - connection type 52

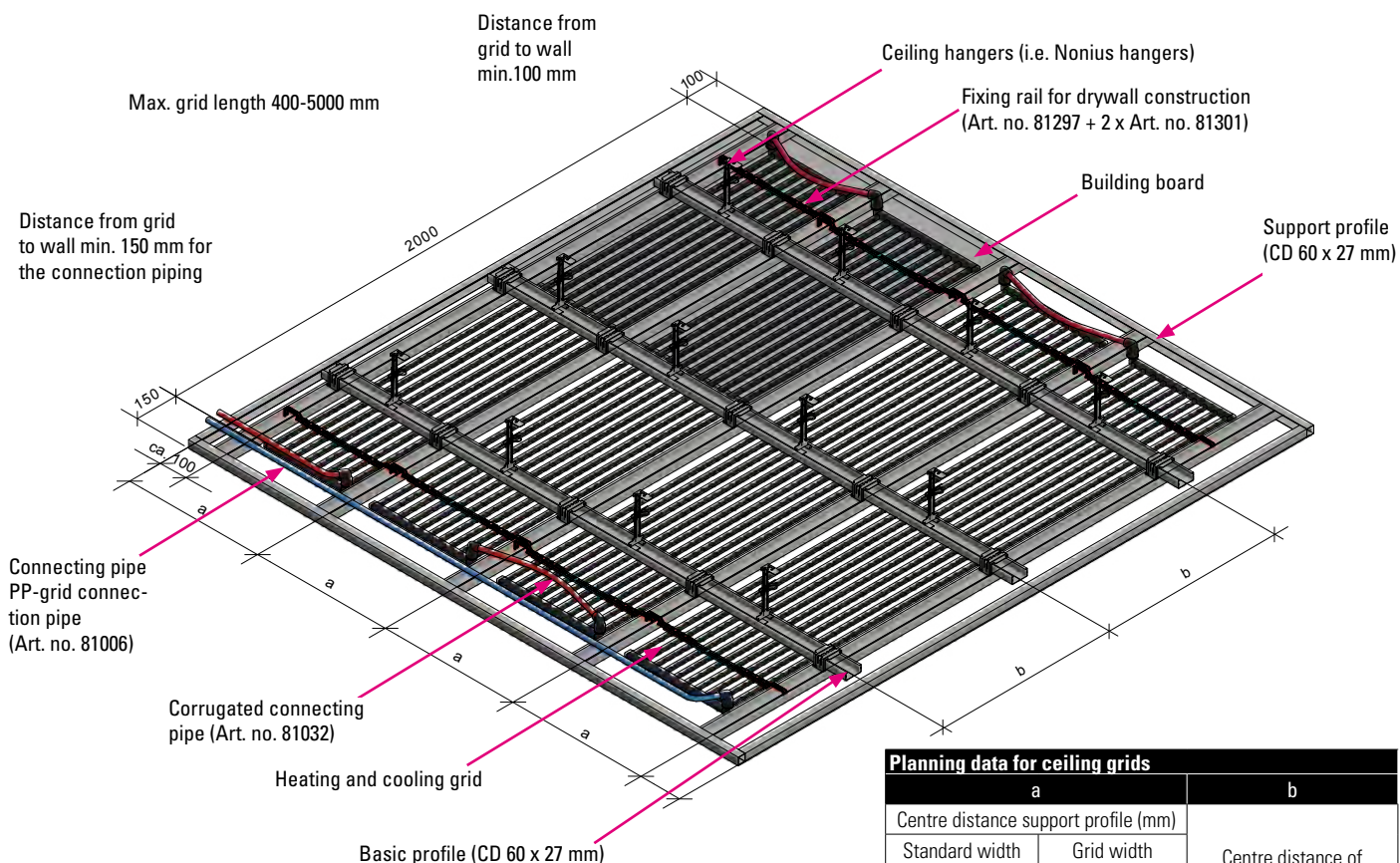

Planning data for ceiling grids		b
a		
Centre distance support profile (mm)		Centre distance of the basic profiles and fixing according to manufacturer
Standard width	Grid width	
333	240	
400	320	
420	320	
500	400	

The grid 333 mm is applied with perforated gypsum plasterboards for sound absorbing heating and cooling systems!

Installation connection type

1. Substructure

The basic and support profiles acc. to DIN 18168-1 are fixed and arranged with hangers (i.e. Nonius hangers) at the slab, subject to manufacturer's instructions.

Connection types 52/62

2. Installation of the grids

To ensure a smooth installation process, the suspension height must be at least 15 cm. The axis centre distance of the supporting construction depends on the building board used and varies between 333 mm and 500 mm. All grids are made to-measure and the installation is carried out according to laying plan between the support profiles. The grids are held to the basic profile of the metal substructure with a magnetic clip (Art. no. 81302). Each grid is additionally fixed with four mounting rails for drywall construction and connecting plugs.

3. Connection of the grids

The grids for installation in a ceiling system for drywall construction are equipped with plug-in sockets connection type 62 (one-sided) or connection type 52 (two-way). After mounting the grids in the substructure, they are combined to heating respectively cooling areas according to the layout plan. For this purpose, the aquatherm black system corrugated pipe is used (see detail connection).

4. Installation of the building boards

The grid hangs some millimeter below the supporting rail. The building boards are now screwed according to manufacturer specifications to the supporting structure and thereby the grids are pushed upwards. This results in a direct contact between building board and grid. It is important to ensure that during the planking the grids are filled with water and are pressurized.

Detail: connection type 62

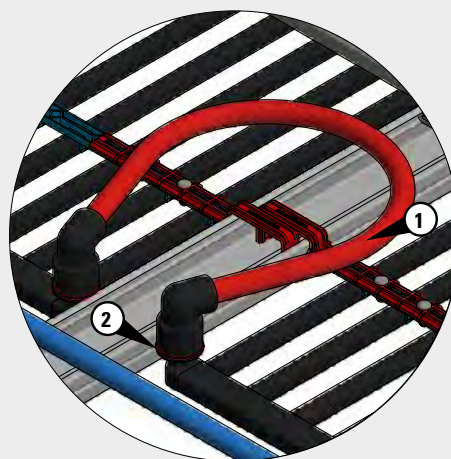

1. Corrugated connecting pipe with plug elbow (Art. no. 81032)
2. Safety clip

Detail: connection type 52

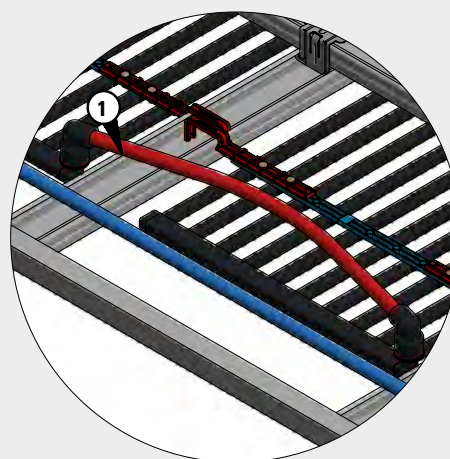

1. Corrugated connecting pipe with plug elbow (Art. no. 81038)

For 333 mm grids the corrugated connecting pipe (Art. no. 81038 / 1000 mm) must be used instead of corrugated connecting pipe (Art. no. 81032 / 500 mm).

Ceiling system with metal substructure and planking with building boards - connection type 62

Detail: fixing rail

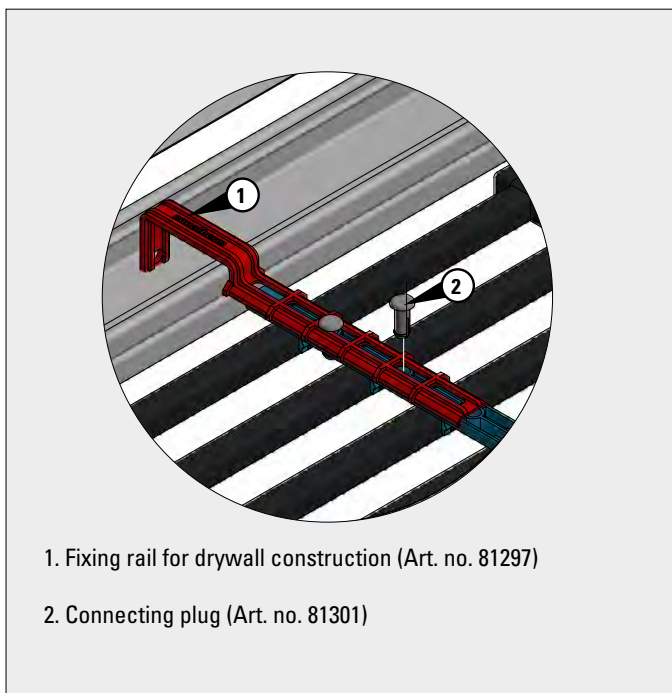

Section: support profile

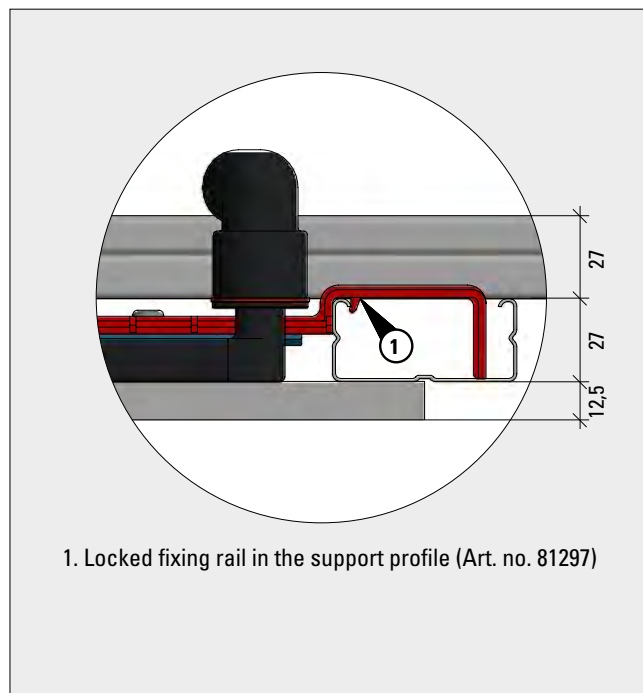

Alternative fixing with magnets

Section: fixing of magnet clip at the metal substructure

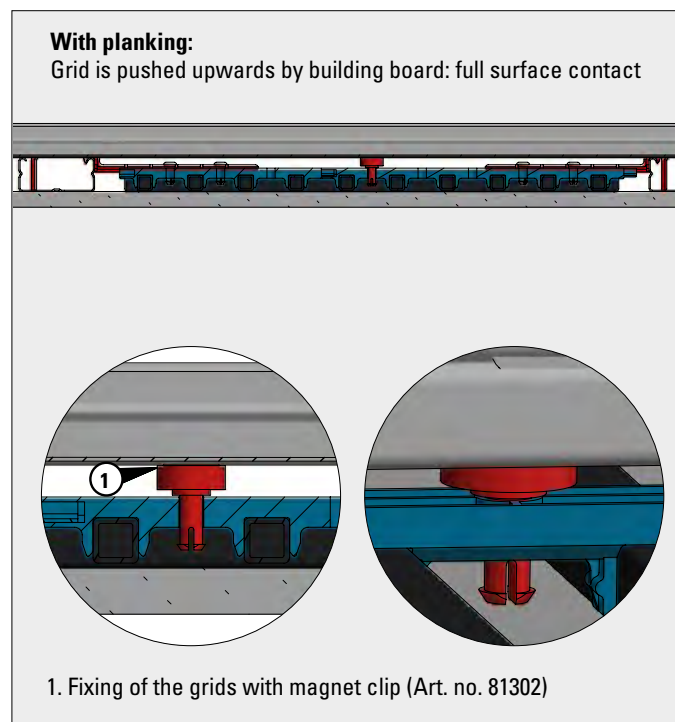
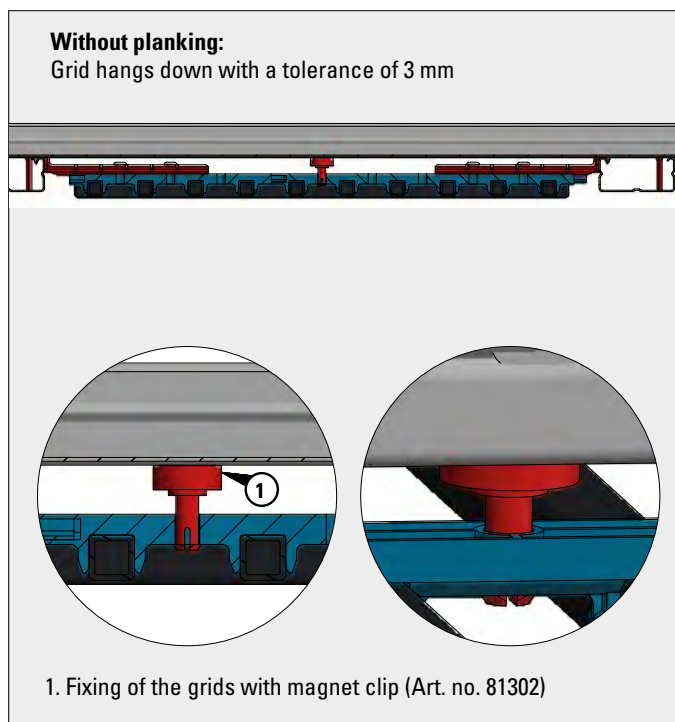

Number of magnets

Magnets	Grid length
0	40 to 120 cm
1	140 to 200 cm
2	225 to 350 cm
3	375 to 500 cm



Ceiling system with wooden substructure and planking with building boards

Description

The installation of the aquatherm black system grids for heating and cooling is done between the support profiles of the wooden substructure. The ceiling is subsequently planked with building boards, for example made of gypsum plasterboard.

Thanks to different grid widths and lengths, the ceiling can be equipped differently, thereby creating space for ceiling installations (spotlights, suspensions for lighting, smoke detectors, etc.)

Advantages

- High heating and cooling performance due to full activation of the ceiling surfaces
- Quick and easy installation
- Ideally suited for use with heat pump and condensing boiler technology due to low flow and return temperatures
- High sound absorption in combination with perforated gypsum plasterboards
- Installation in combination with various ceiling installation/superstructures such as lights, fire detectors and ventilation components
- Power output without drafts
- Short heating and fast reaction times
- Rapid construction progress thanks to dry construction system

Ceiling system with wooden substructure and planking with building boards - connecting type 64

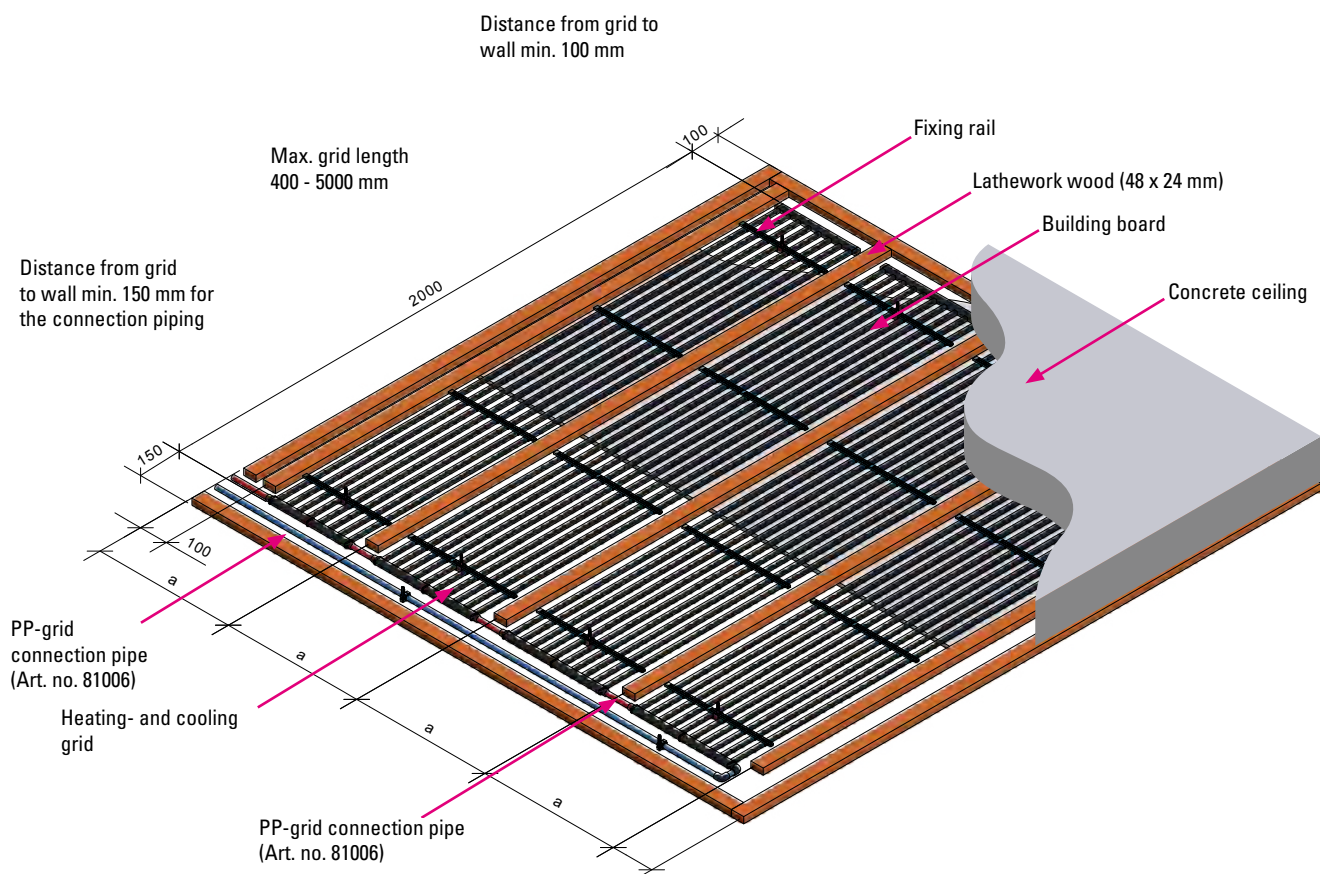

Installation

1. Substructure

The support battens are attached to the ceiling according to the manufacturer's specifications and are arranged either vertically or horizontally.

2. Installation of the grids

The axis centre distance of the supporting construction depends on the building board and varies between 333 mm and 500 mm. All grids are made to-measure and installation is made between the battens.

The grids are screwed directly to the concrete ceiling. The fastening element with dowel is inserted into the fixing rail and screwed to the concrete ceiling. Alternatively, mounting by using a Hilti mounting device (see page 95) is recommended.

3. Connection of the grids

The grids for installation in a ceiling system with wooden substructure are supplied with welding sockets, connection type 64. After mounting the grids to the ceiling between the wooden lathwork, they are combined to heating respectively cooling areas according to the layout plan. For this purpose, the aquatherm black system connecting pipe is used. The fixing of the connecting pipes is made with fixing clamp (see detail).

4. Installation of building boards

The grid is mounted between the wooden lathwork. The building boards are now screwed according to the manufacturer's instructions to the battens. Take care that during planking the grids are filled with water and are pressurized.

Planning data for ceiling grids

a	
Standard width supporting batten (mm)	Grid width (mm)
400	320
420	320
500	400

Detail: Connection

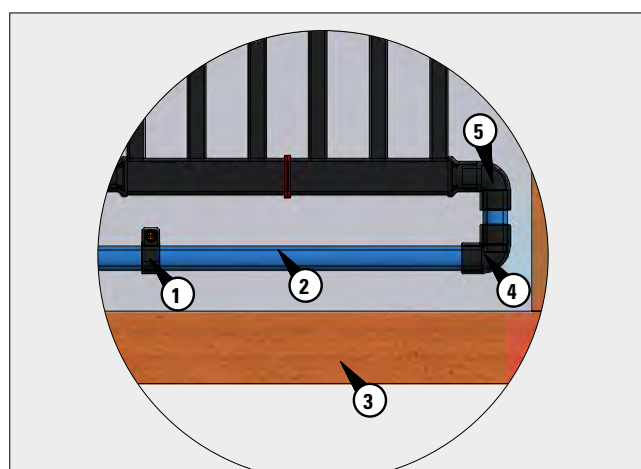

1. Plastic pipe clamp (Art. no. 60716)
2. Connecting pipe (Art. no. 81006)
3. Lathwork wood (48 x 24 mm)
4. Elbow 90° (Art. no. 81060)
5. Elbow 90° m/f (Art. no. 81065)

Ceiling system with wooden substructure and planking with building boards - connecting type 64

Section: Grid fixing ceiling

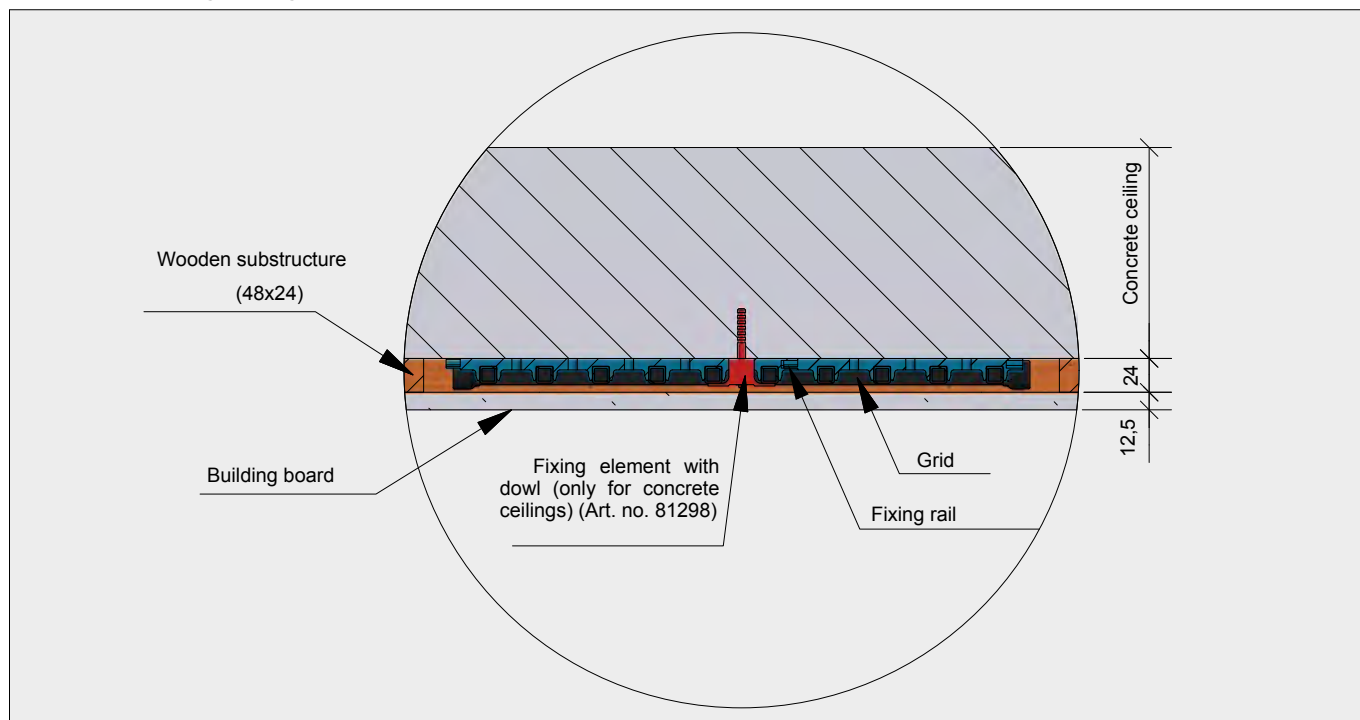

Detail: Fixing of connection pipe

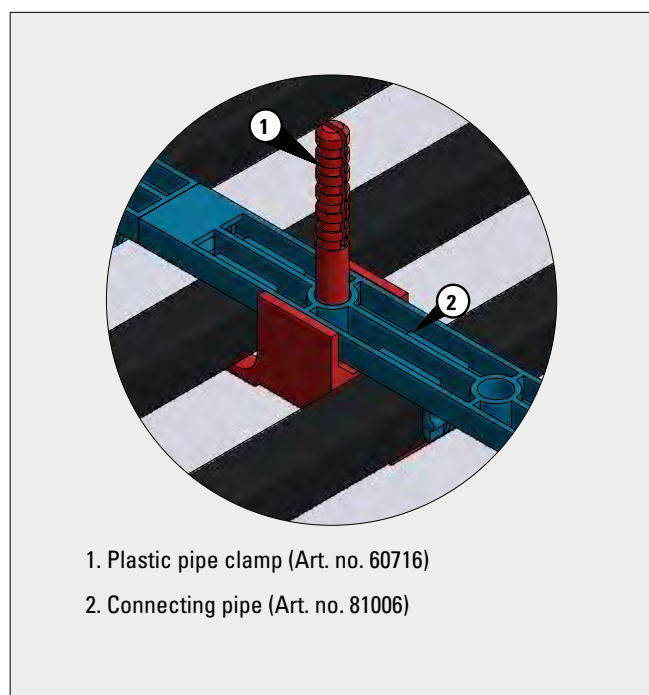

Detail: Grid fixing ceiling

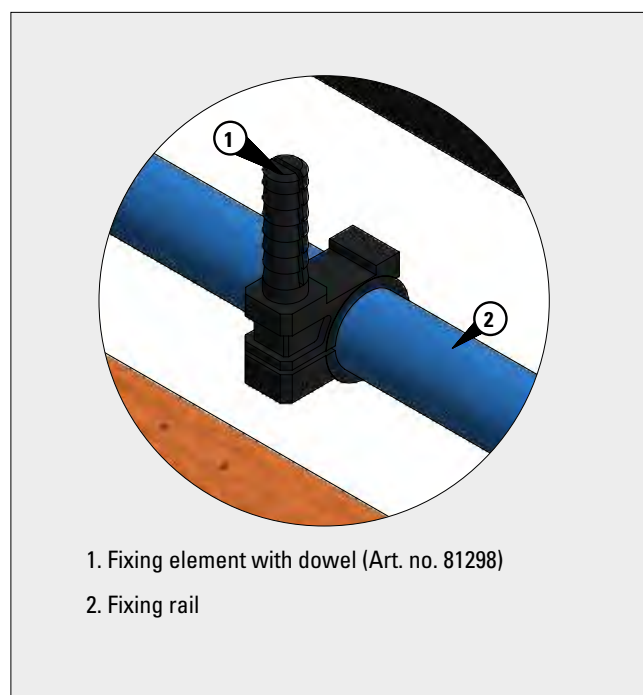

Performance data ceiling system with building boards

Standard **heating capacity** according to DIN EN 14037-2

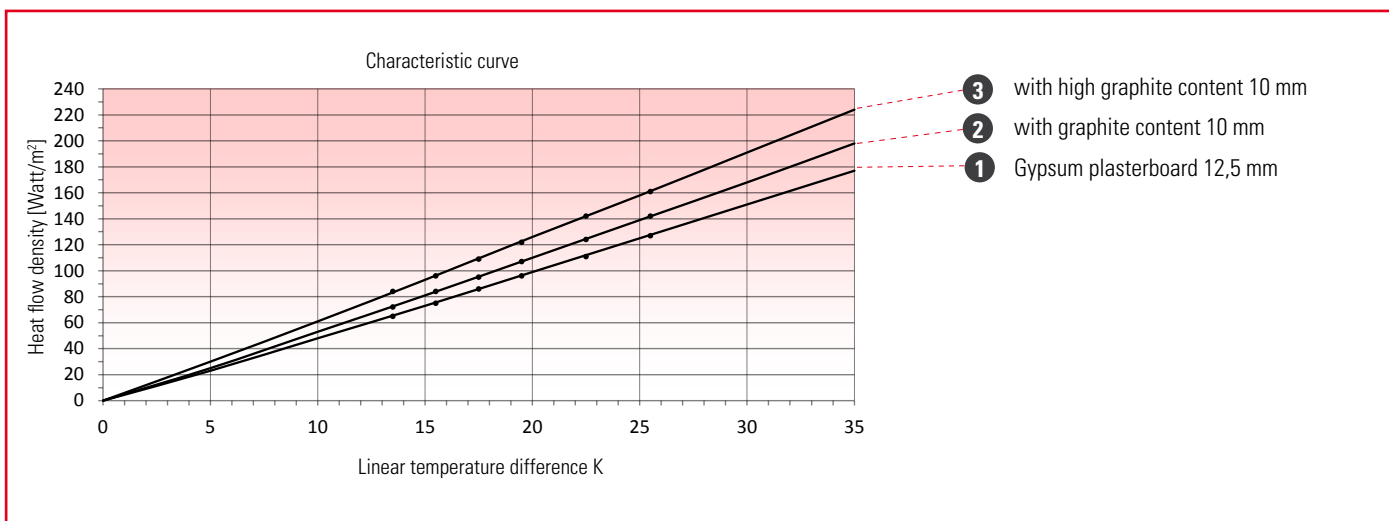

Calculation example for: flow temperature 40 °C / return temperature 35 °C

Linear temperature difference K	13,5	15,5	17,5	19,5	22,5	25,5
Room temperature °C	24	22	20	18	15	12
① Gypsum plasterboard 12,5 mm W/m ²	65	75	86	96	111	127
② with graphite content 10 mm W/m ²	72	84	95	107	124	142
③ with high graphite content 10 mm W/m ²	84	96	109	122	142	161

Standard **cooling capacity** according to DIN EN 14240: 2004-04

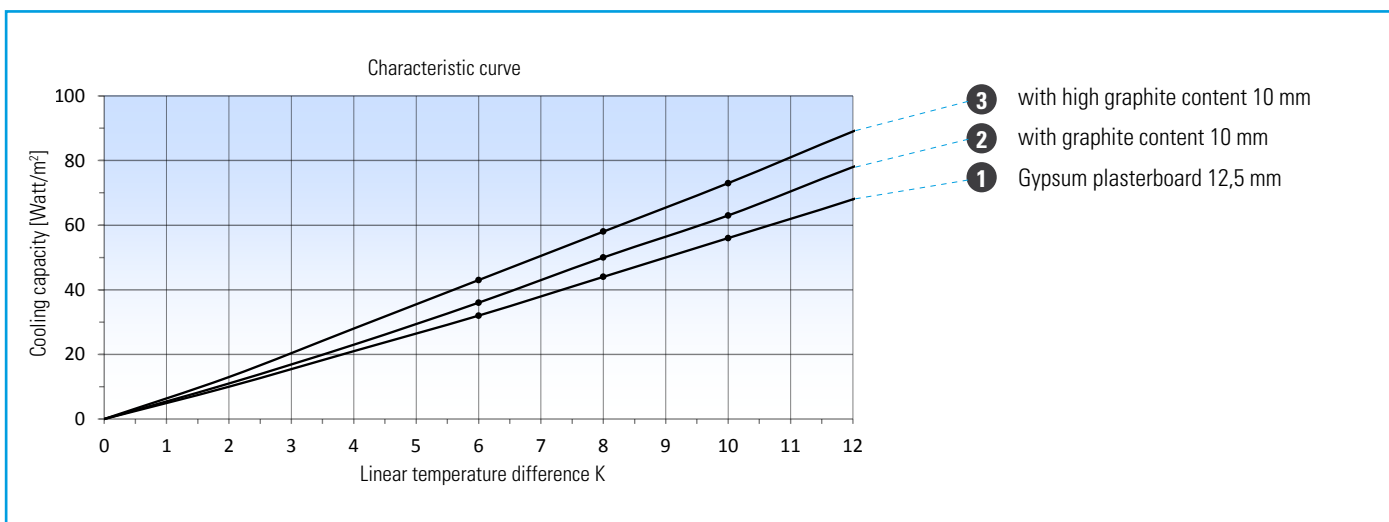

Calculation example for: flow temperature 15 °C / return temperature 17 °C

Linear temperature difference K	6	8	10
Room temperature °C	22	24	26
① Gypsum plasterboard 12,5 mm W/m ²	32	44	56
② with graphite content 10 mm W/m ²	36	50	63
③ with high graphite content 10 mm W/m ²	43	58	73

Ceiling system with building boards

Specification of different panel designs

Design	Punching	Punching percentage (panel) %	Weight without insulation layer kg/m ²	Support profile maximum centre distance mm
Straight round punching	6/18 R	8,7	ca. 12	333
	8/18 R	15,5	ca. 12	333
	12/25 R	18,1	ca. 12	333
Scattered punching	10/16/22 R	12,6	ca. 12	333
Straight square punching	8/18 Q	19,8	ca. 12	333
	12/25 Q	23,0	ca. 12	333

Advice: Weight for bigger panel sizes and/or different panel types on request

Straight round punching 6/18 R

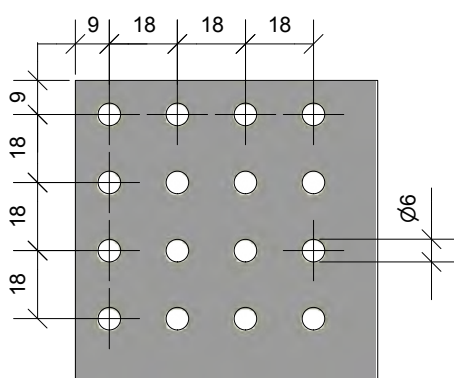

Straight round punching 8/18 R

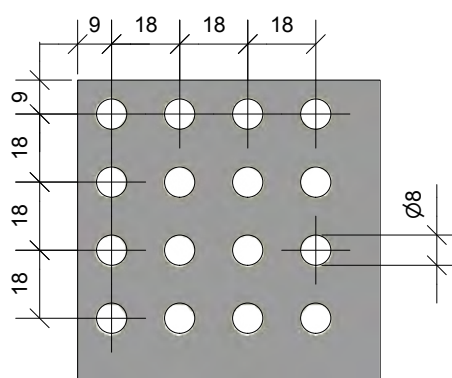

Straight round punching 12/25 R

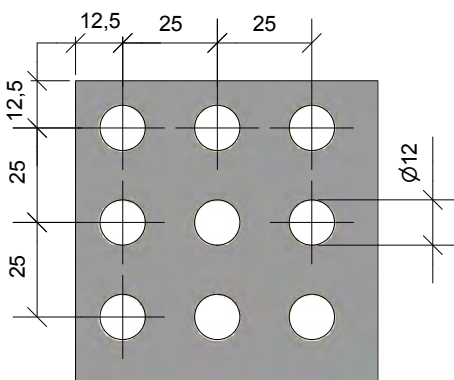

Sprinkled punching 10/16/22 R

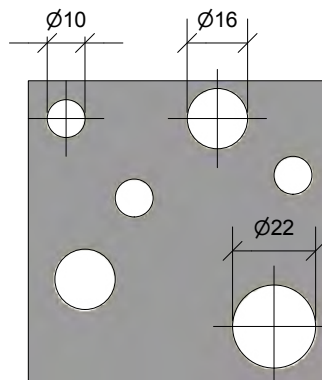

Straight square punching 8/18 R

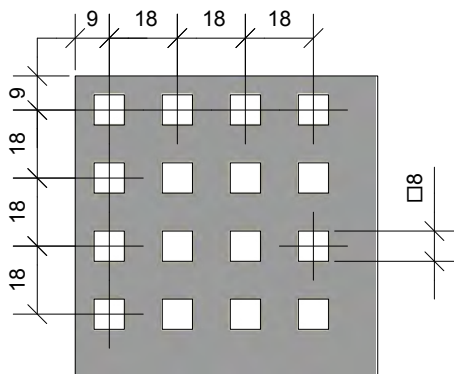

Straight square punching 12/25 R

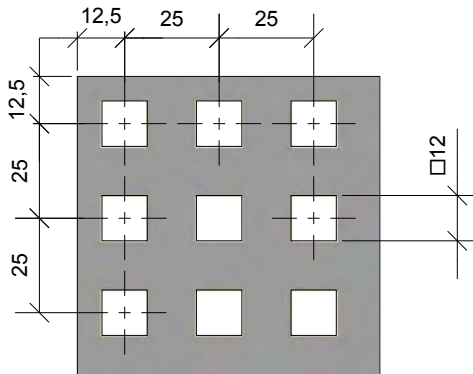

Installation example

Ceiling system gypsum plasterboards - single layer planking

Centre distance support profile punched gypsum plasterboard = 333 mm

Centre distance non-punched gypsum plasterboard = 400 mm und 500 mm

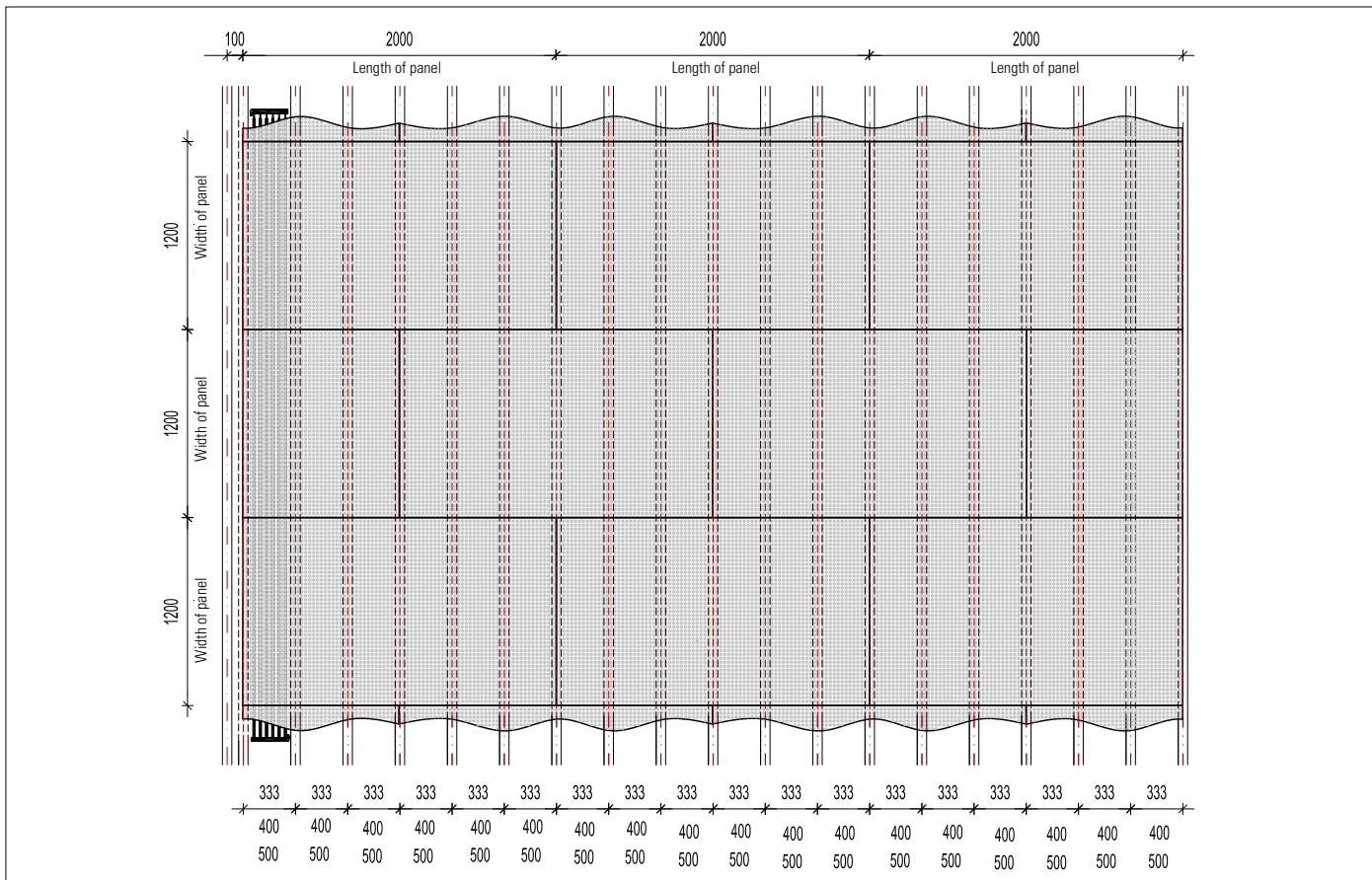

Installation example

Ceiling system gypsum plasterboards - single layer planking

Centre distance support profile = 415 mm

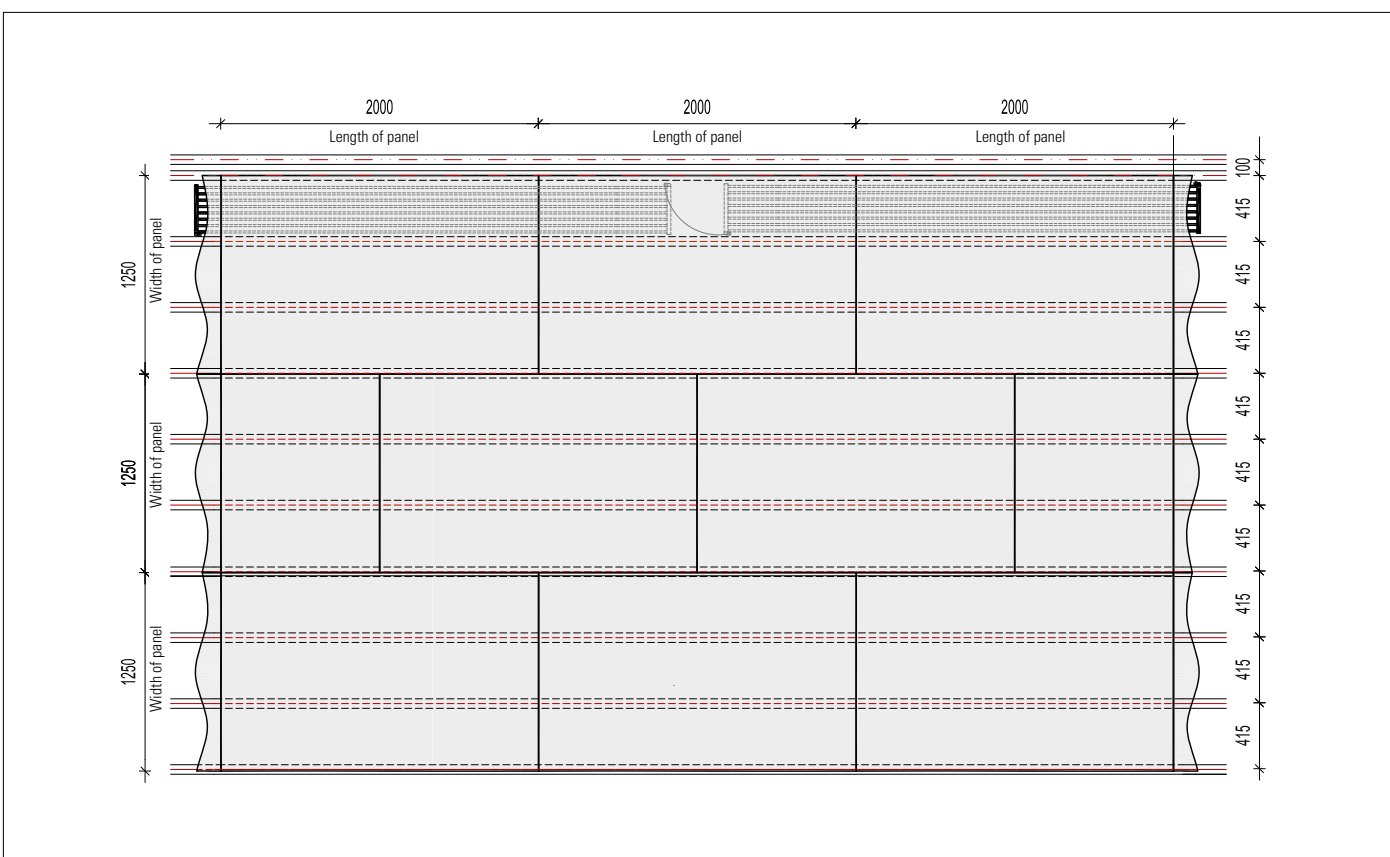



Ceiling system with insertion plates made of gypsum plasterboard or mineral fibre

Description

The aquatherm black system grids for heating and cooling are glued to the insertion plates made of plasterboard or mineral fibre on site. A good power transmission is guaranteed by the direct contact between grid and insertion plate.

Advantages

- *High heating and cooling performance due to excellent contact with the insertion plates*
- *Prefabricated grids for quick assembly on site*
- *Ideally suited for use with heat pump and condensing boiler technology due to low flow and return temperatures*
- *Can be retrofitted in existing ceiling systems*
- *High sound absorption of the ceiling panels with perforation and acoustic fleece*
- *Installation in combination with various ceiling installation /superstructures such as lights, fire detectors and ventilation components*
- *Power output without drafts*
- *Soundless and non-visible heating and cooling*

Ceiling system with insertion plates made of gypsum plasterboard or mineral fibre - connection type 62

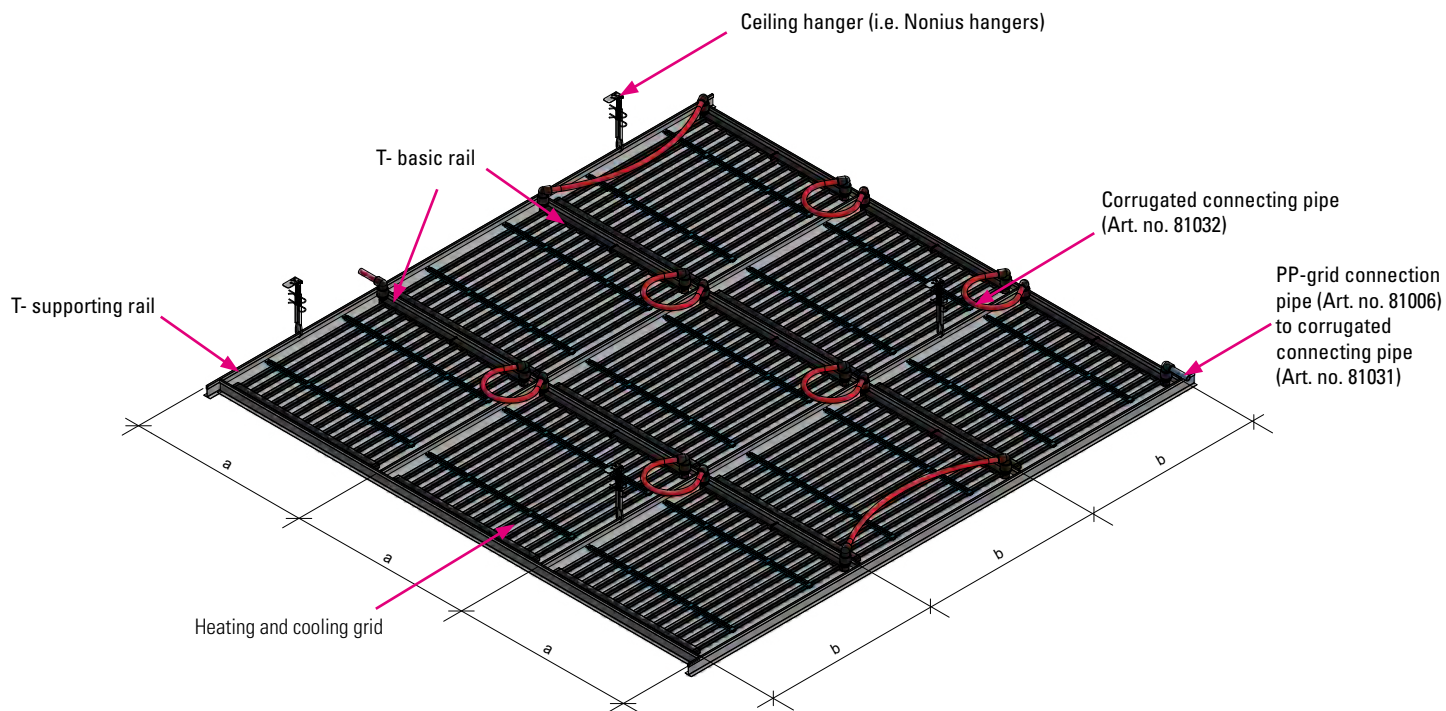

Installation

1. Substructure

According to the manufacturer, the substructure is to be fixed to the raw ceiling by the drywall builder with ceiling hangers (i.e. Nonius hangers) and aligned. If a substructure is available, only the suitability of the selected insertion plates must be checked.

2. Assembly of the grids

For a smooth installation, the middle suspending height of the systems with insertion plates should be at least 15 cm. The custom-made grids are glued to the insertion plates according to the installation plan (see page 39). Depending on requirements, a mineral wool insulation (at least 30 mm), sealed in PE foil, can be placed on the grids.

3. Connection of the grids

The grids for installation in a ceiling system for insertion plates are equipped with plug-in socket connection type 62 (single-sided) or connection type 52 (mutual). After mounting the grids on the insertion plates, they are connected to each other to heating or cooling zones pipe according to the installation plan. The aquatherm black system corrugated pipe is used for this (see detail: connection piping).

ADVICE:

Building plate with graphite content or high graphite content for the insertion system only on request.

Planning data for ceiling grids		
Dimension building plate (mm)		Grid (mm)
a	b	
600	600	520 x 560
625	625	560 x 600
600	1200	520 x 1150
625	1250	560 x 1200
Distances of substructure according to manufacturer Special solutions on request		

Detail: Connecting piping between the grids

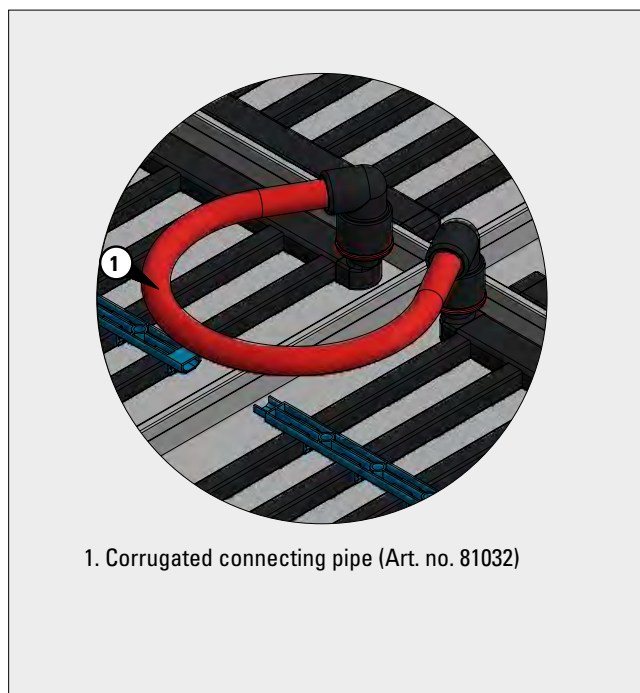

Section: grid fixing ceiling

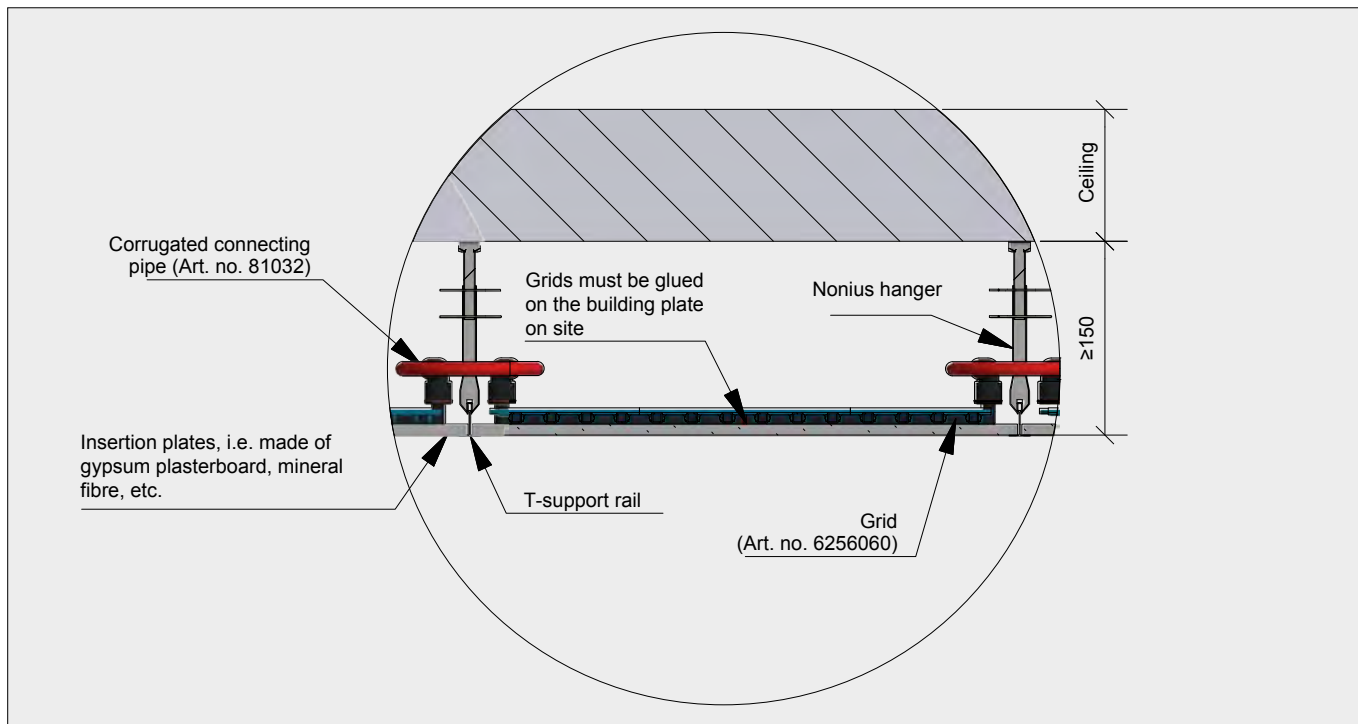

Installation examples of additional insertion plates for standard T-rails:

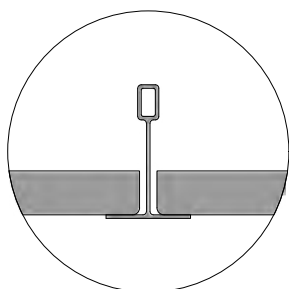

level insert

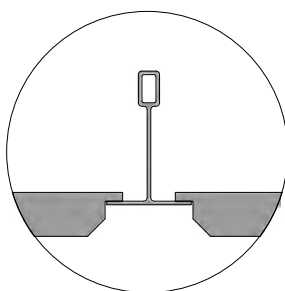

Deep embossing with chamfer

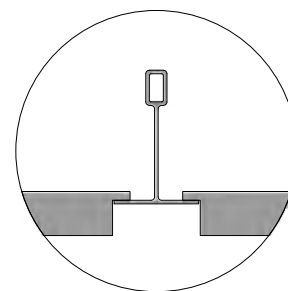

Deep embossing sharp-edged

The plastic grids must be glued on site.

The plastic grid is glued to the insertion plate with a suitable contact adhesive. In this process, a very good heat transfer can be ensured by full-surface bonding.



Adhesive and solvent for sticking the aquatherm grids on the building plates can be obtained directly from the manufacturer Wakol GmbH (www.wakol.de). The manufacturer's instructions are to be considered!

Article name Glue: L1720 RED
Article name Solvent: Solver 31

Ceiling system with insertion plates

Specification of different plate designs:

Design	Punching	Hole content (plate) %	Weight kg/m ²
Round punching	Ø6	10,5	8,2
Square punching	9x9	16,3	8,1
	12x12	12	8,1
Slot	4x14	21,1	8,1
Sprinkled punching	Ø8/15/20	10,8	8,2
Unpunched		0	9,9

Advice: Weight for bigger plate thickness and/or different types of plates on request.

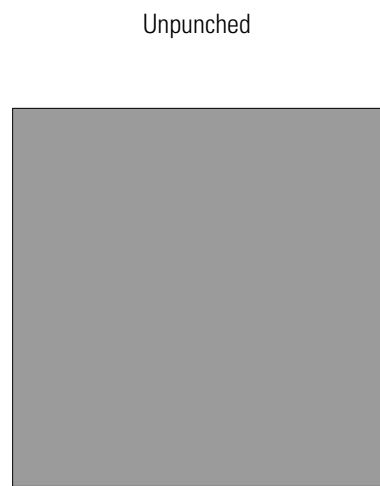
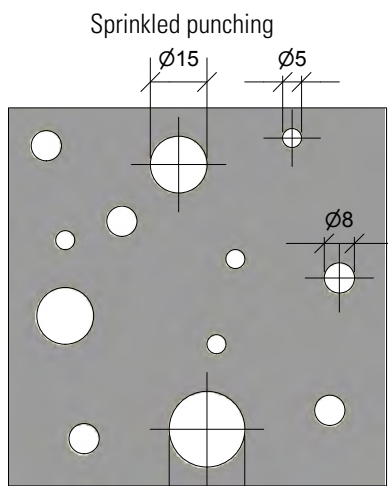
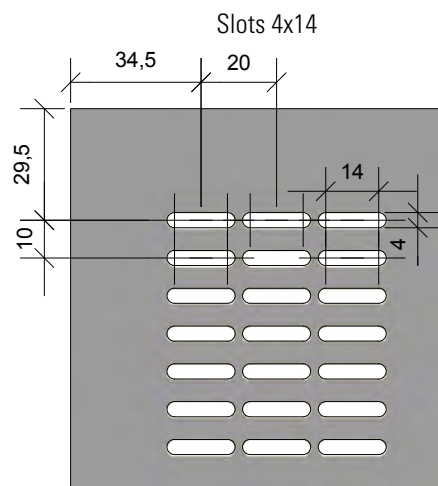
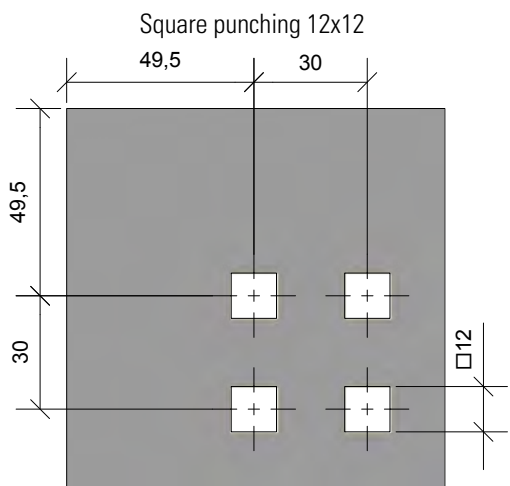
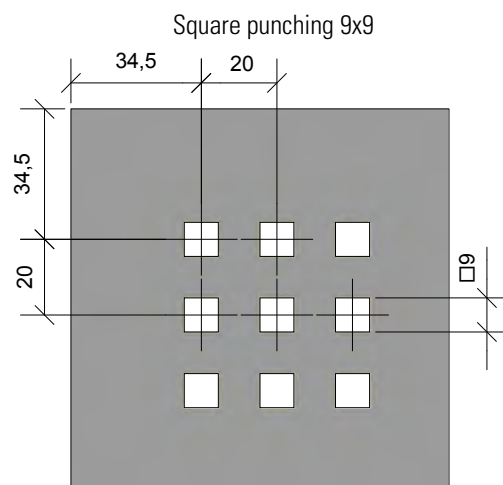
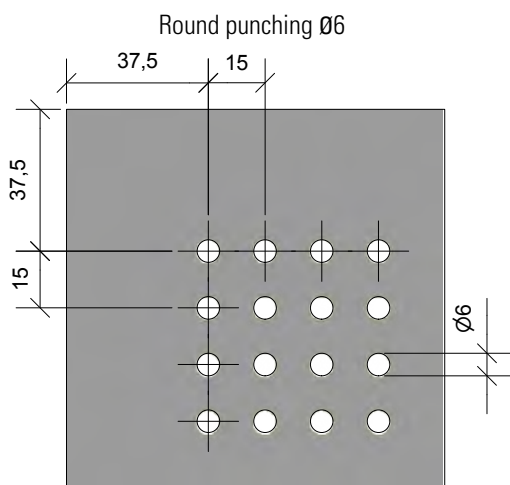

Performance data ceiling system with insertion plates

Standard **heating capacity** according to DIN EN 14037-2

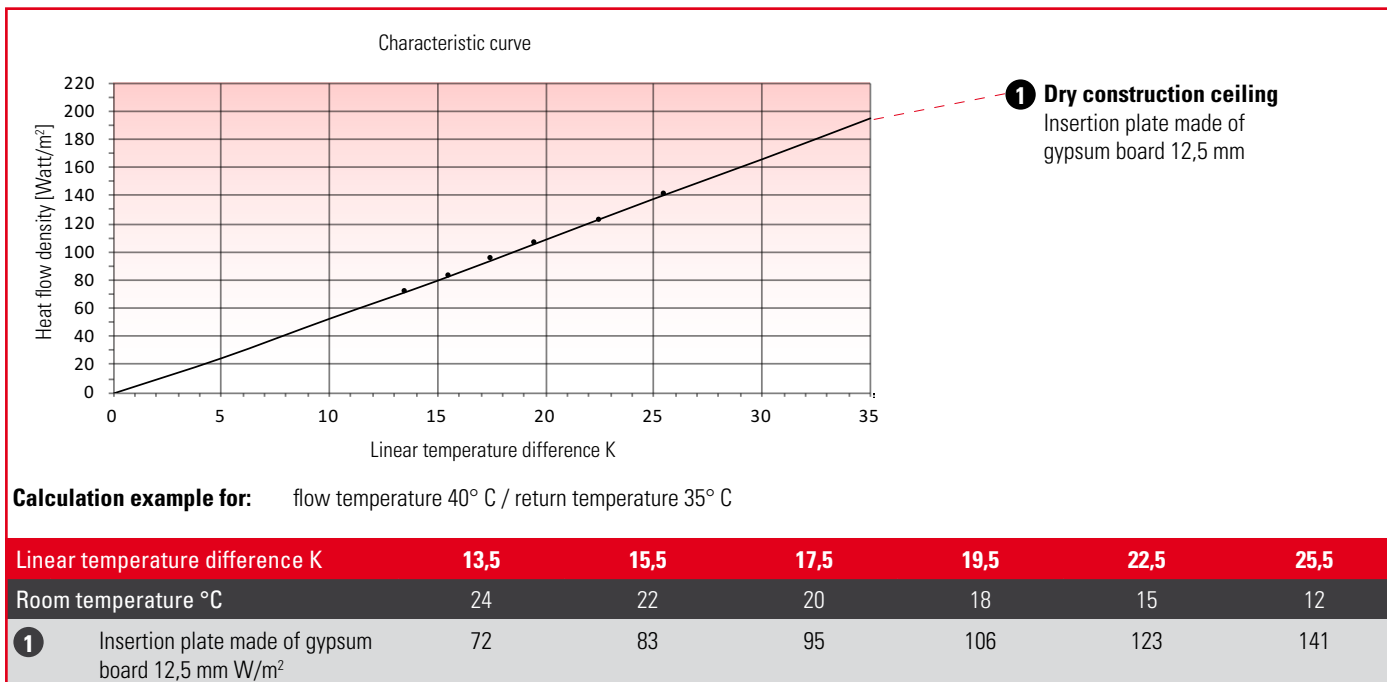

Standard **cooling capacity** according to DIN EN 14240: 2004-04

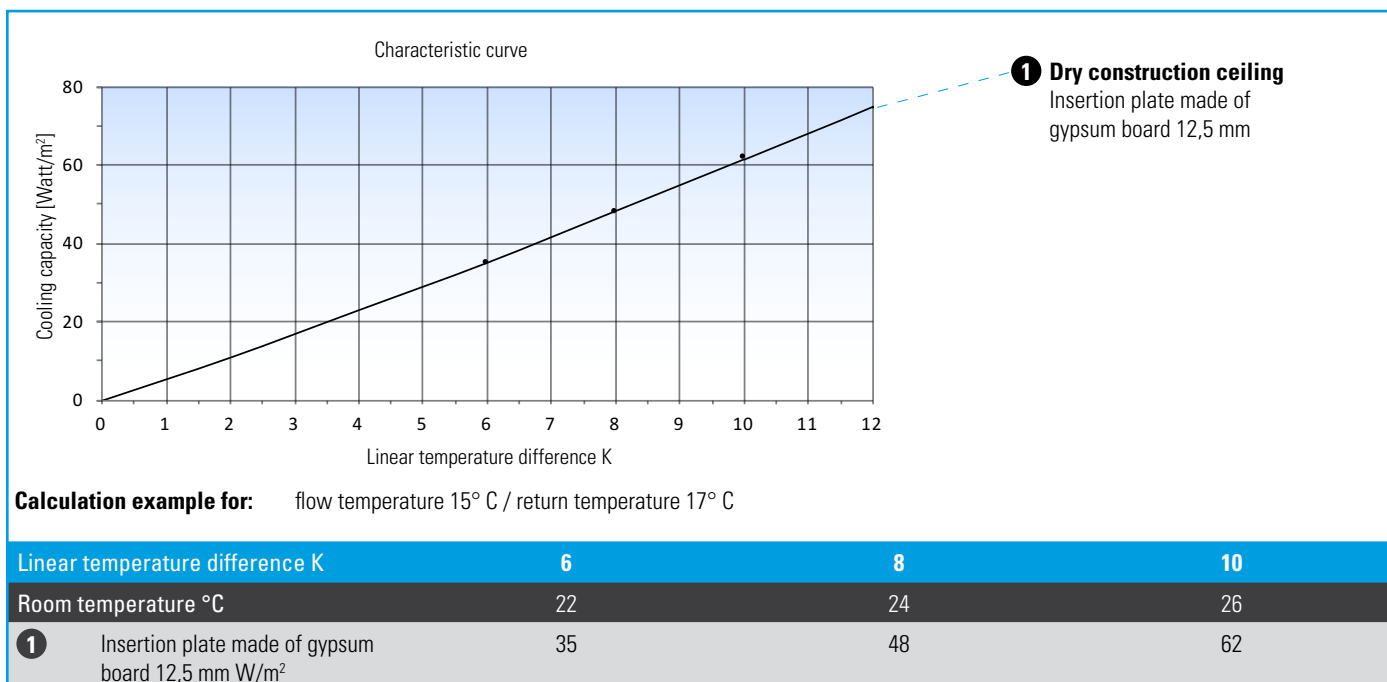



Ceiling system plastered

Description

The freedom of design is a big plus: the aquatherm black system grids can be individually adapted in shape and size to any room geometry. The grids and the connection piping are attached to the ceiling. Then plastering is made in compliance with the general plaster guidelines. All commercially available plasters made of gypsum, lime, cement and clay are suitable.

Advantages

- *High heating and cooling performance due to full activation of the ceiling surfaces*
- *Silent, draft-free heating and cooling function*
- *Short heating and fast reaction times*
- *Pleasant room climate*
- *Installation is possible on all ceiling surfaces*

Substrate

1. Substrate requirements

The substrate must be dry and flat to accommodate the plaster according to the manufacturer's instructions. Plasters can usually be applied to all plaster substrates. Regarding the adhesion, a distinction must be made between easy-to plaster and difficult substrates. The choice of plaster, the working method and the pre-treatment of the substrate must be adjusted to the local conditions. The test of the substrate by the contractor (plasterer) is compulsory according to VOB part C, DIN 18350 resp. VOB, part B, DIN 1961. The tolerances of the altitude and inclination of the supporting ground must comply with DIN 18202. Plasterworks should only be performed by specialist companies with appropriate evidence. The check of the substrate conditions for plaster-

works is made by the specialist companies. Due to the processing (one-ply or two-ply plaster), only the layer thickness of the plaster used changes when heating grids are installed.

The ground check of the specialist company is made by

- optical check
- smear test (hand check)
- scratch test (spatula, trowel, etc.)
- wetting test (check, if there are residues of release agent)
- CM-device (measurement of moisture content)
- temperature measurement (at low temperatures)

After the substrate check, the material for pretreatment is selected. Suitable methods are:

- primer coat
- burn-up barrier
- primer
- metallic plaster base (for critical substrates)

Basically, the guidelines and instructions of the plaster manufacturer must be observed.

2. Installation of the grids

The grids are connected to grid pairs by heating element socket welding according to the assembly drawings. Now the grids, respectively the grid pairs are fixed with the supplied aquatherm black system fixing clamp with wall plug

Ceiling system plastered

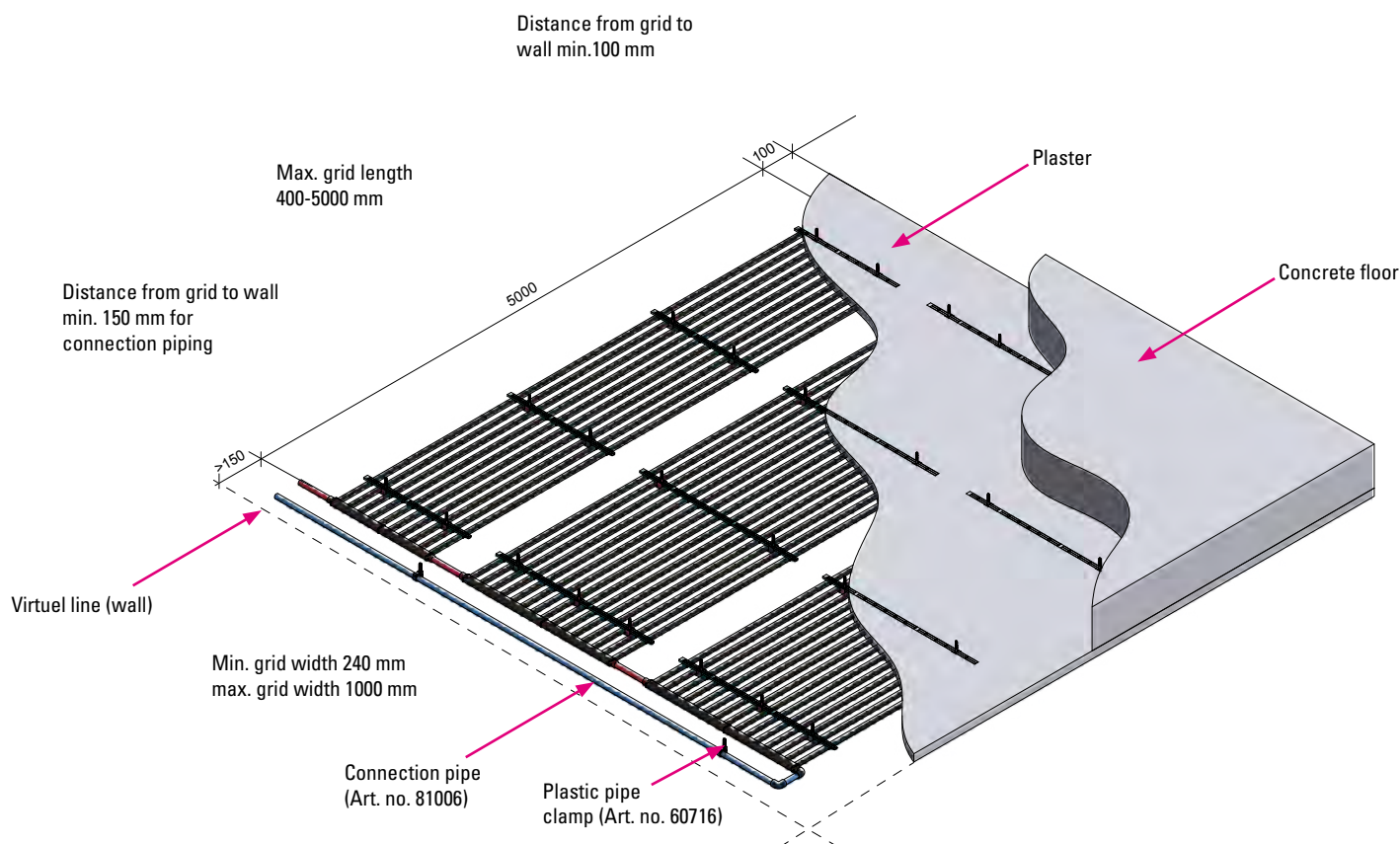

at the slab according to the layout drawing. The fixing clamp is plugged in the slab through the fixing rail, which is at intervals at the grid. Consider: the fixing clamp with wall plug in conjunction with the fixing rail can be used as plaster base depending on the plaster substrate, type and manufacturer. Supplementary plaster base aids (plaster grids) in the grid area will be omitted. However, it must be ensured that necessary measures are taken in the plaster areas without grids. Processing guidelines of the plaster manufacturers are binding and mandatory.

We recommend 8 aquatherm black system fixing elements with dowel per m².

The aquatherm black system PP grid pipe 16x2 mm is used to connect the grids with each other, respectively the grid zones to the distributor. This pipe, if it has also been attached to the slab (e.g. with aquatherm black system plastic fixing clips), can also be plastered in.

Alternatively, the attachment with the Hilti fastening device (see page 95) is recommended.

3. Connection of the grids

If the aquatherm black system grids are arranged horizontally, the flow can be connected either left or right. The grids for installation in a ceiling system with plaster are provided with welding sockets (connection type 64). After installing the grids at the slab, they are connected to heating and cooling zones according to the laying plan.

The connection of the heating or cooling circuits to the distributor or the main supply is made with aquatherm black system PP grid pipe 16x2 mm.

4. Plastering the grids

Now the ceiling can be plastered with 10 mm plaster covering from the top edge of the heating pipe according to manufacturer's instructions. Care must be taken to ensure that the grids are filled with water during the plasterworks and are under pressure.

Detail: view from below

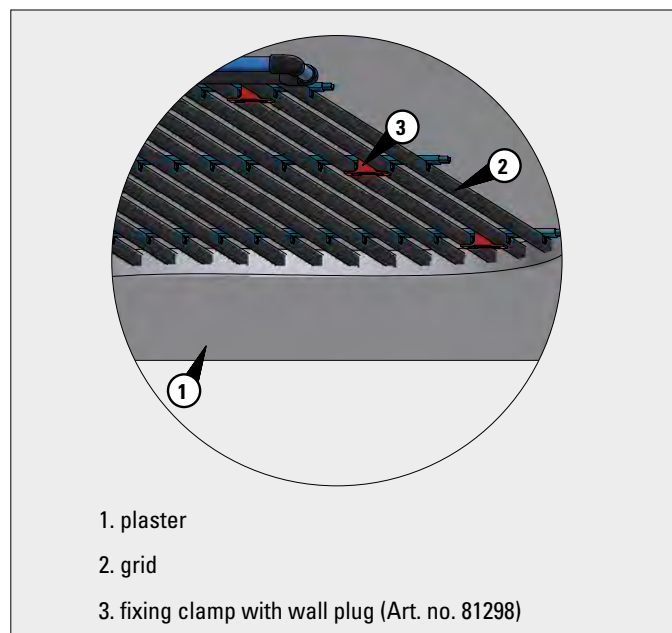

Ceiling system plastered

Section: grid fixing ceiling

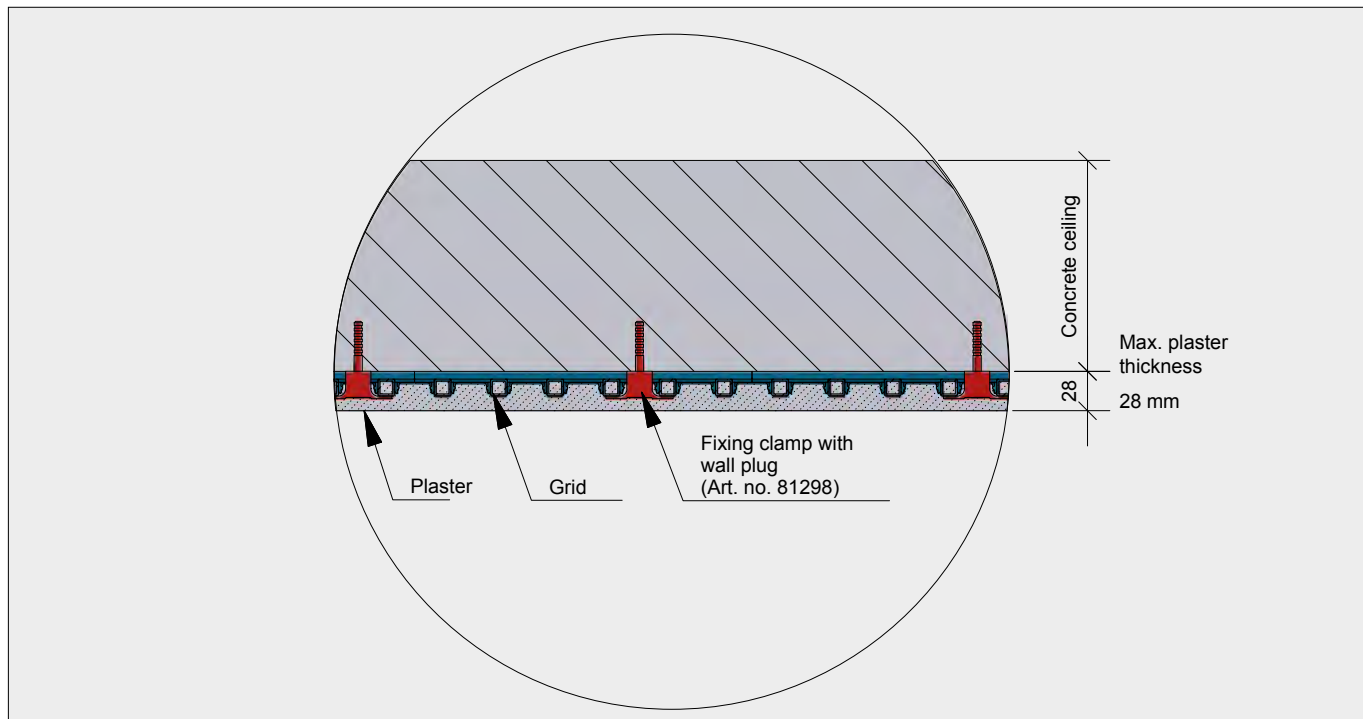

Detail: grid fixing ceiling

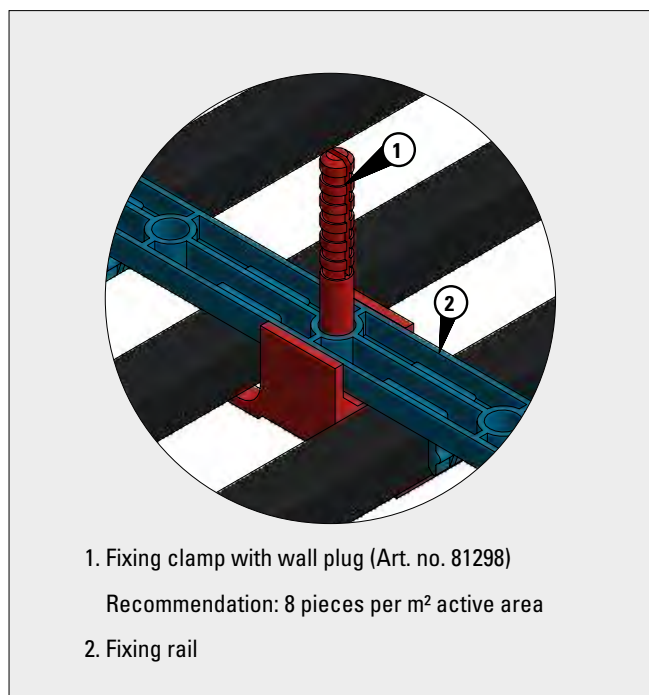

Detail: fixing of connection piping

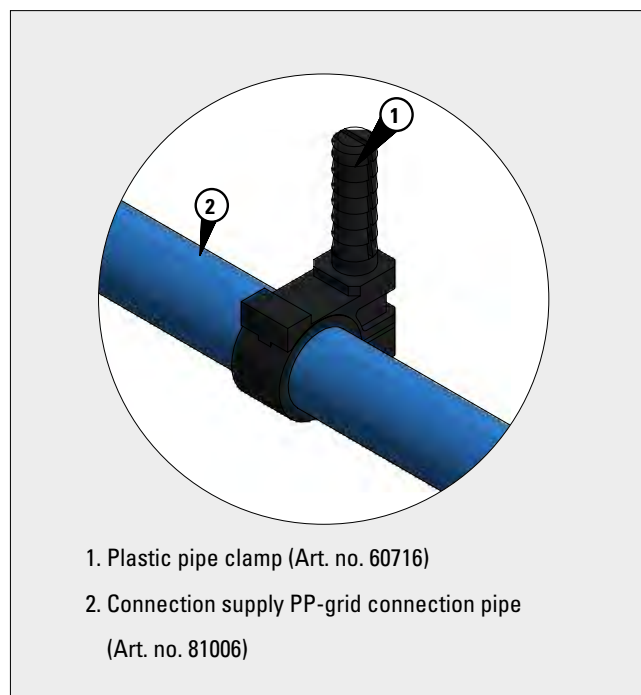

Performance data ceiling system plastered
Standard heating capacity according to DIN EN 14037-2

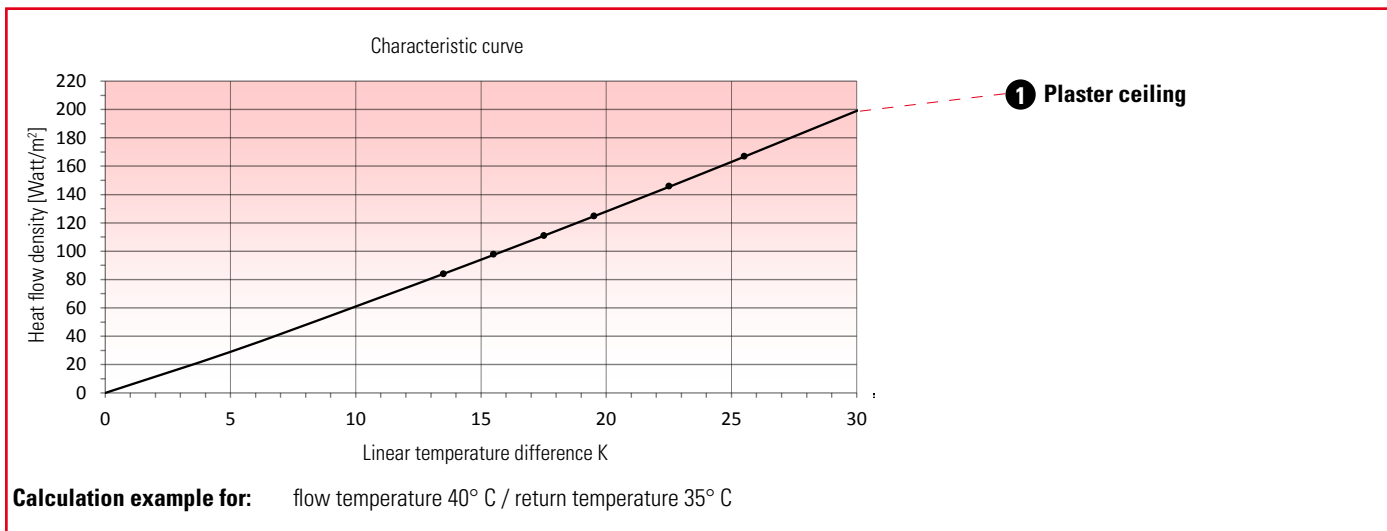

Linear temperature difference K	13,5	15,5	17,5	19,5	22,5	25,5
Room temperature °C	24	22	20	18	15	12
1 Plaster ceiling W/m²	84	98	111	125	146	167

Standard cooling capacity according to DIN EN 14240: 2004-04

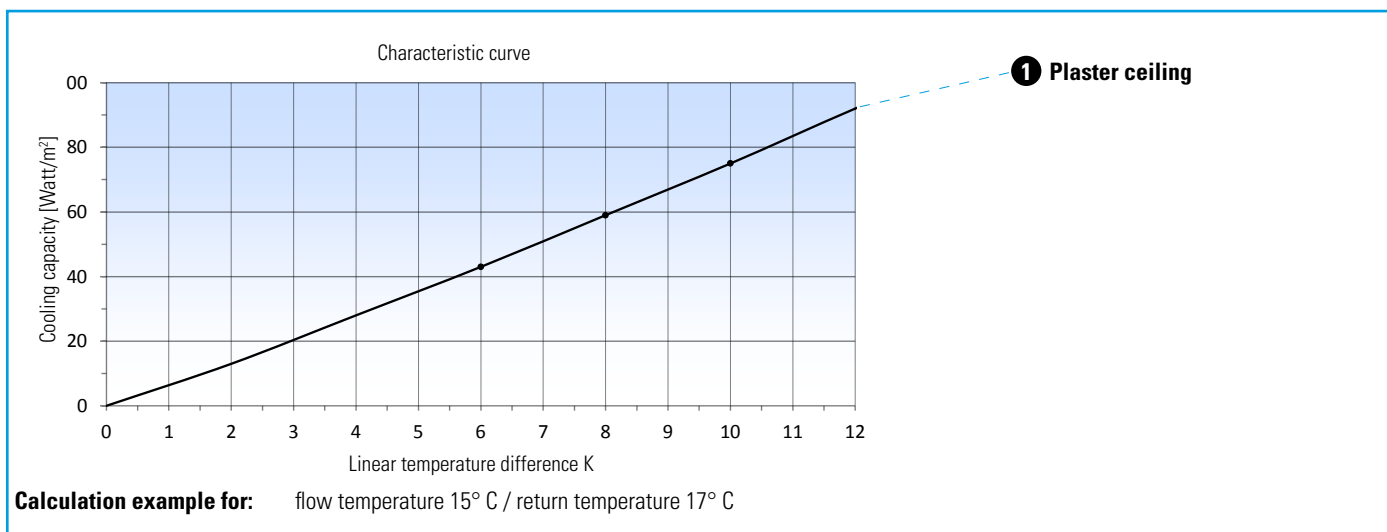

Linear temperature difference K	6	8	10
Room temperature °C	22	24	26
1 Plaster ceiling W/m²	43	59	75



Metal panel ceiling as clamping system

Description

The aquatherm black system grids for heating and cooling are inserted into the metal ceiling panels and fixed with magnet holders. A good power transmission is guaranteed due to the contact of the grid and metal plate.

Advantages

- High heating and cooling performance due to excellent contact transfer area
- Prefabricated grids for quick installation on site
- Very easy installation with magnet holders
- Combination with centrally conditioned outside air is possible
- Can be retrofitted in existing metal ceiling systems
- High sound absorption in metal ceiling panels with microperforation
- Installation in combination with various ceiling fixtures/structures such as lights, fire detectors and ventilation components
- Soundless and invisible heating and cooling

Sound absorption

Not only in office buildings the room acoustic is an important factor. A minimization of the sound propagation and thus a better speech intelligibility can be achieved by a high degree of sound absorption.

Acoustic values of a standard metal ceiling

Frequency (Hz)	125	250	500	1000	2000	4000
α_p	0,35	0,80	0,90	0,65	0,70	0,65
Sound absorption degree in metal ceiling system with proportional perforation type 2516						
Evaluation according to ISO 354						
Practical sound absorption coefficient according to ISO 11654						
$\alpha_w = 0,70$ (L)						
Sound absorption class C						

Metal panel ceiling as clamping system - connection type 62

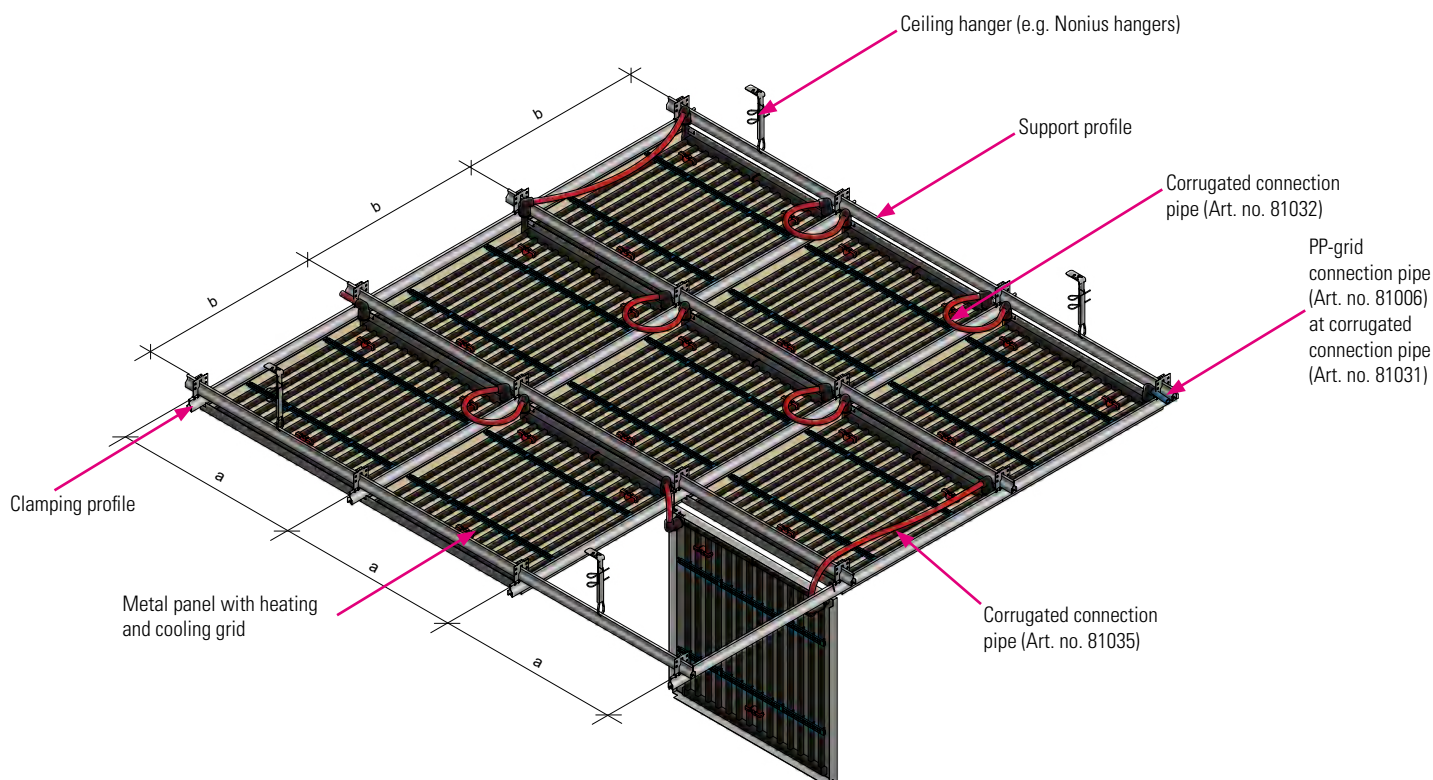

Planning data for ceiling grids

Dimension building plate (mm)		Grid (mm)
a	b	
600	600	520 x 560
625	625	560 x 600
Distances of the substructure according to manufacturer		
Special solutions on request		

Installation

1. Substructure

The substructure is accommodated invisibly in the ceiling cavity as a clamping system according to the manufacturer's specifications.

2. Assembly of the grids

For a smooth installation flow, the average drop height of the metal panel should be at least 15 cm. The grids, object-related and made to measure, are inserted in the panels and fixed with magnet holders according to the installation plan. Depending on the requirements a rock wool insulation (min. 30 mm), welded in a PE-film, can be laid on the grids.

3. Connection of the grids

The grids for the installation in a clamping system ceiling are supplied with 90° plug sockets (connection type 62) in one-sided design. After the installation of the metal clamping panels with integrated grids in the clamping rail, they are connected to heating or cooling zones according to the layout plan. For this purpose, prefabricated corrugated connecting pipes with 90° plug adapters are used. Ensure that the corrugated connection pipe is long enough so that the ceiling can be opened easily in the predetermined folding direction. The transition to the connecting supply is made by heating-socket-welding.

4. Installation of the clip-in panel ceiling

The mounting of the clamping panel ceiling must always follow the manufacturer's instructions. In principle, the heating/cooling system must be filled with water and pressurized.

Detail: connection piping between the grids



1. corrugated connection pipe (Art. no. 81032)

Metal panel ceiling as clamping system - connection type 62

Section: grid fixing ceiling

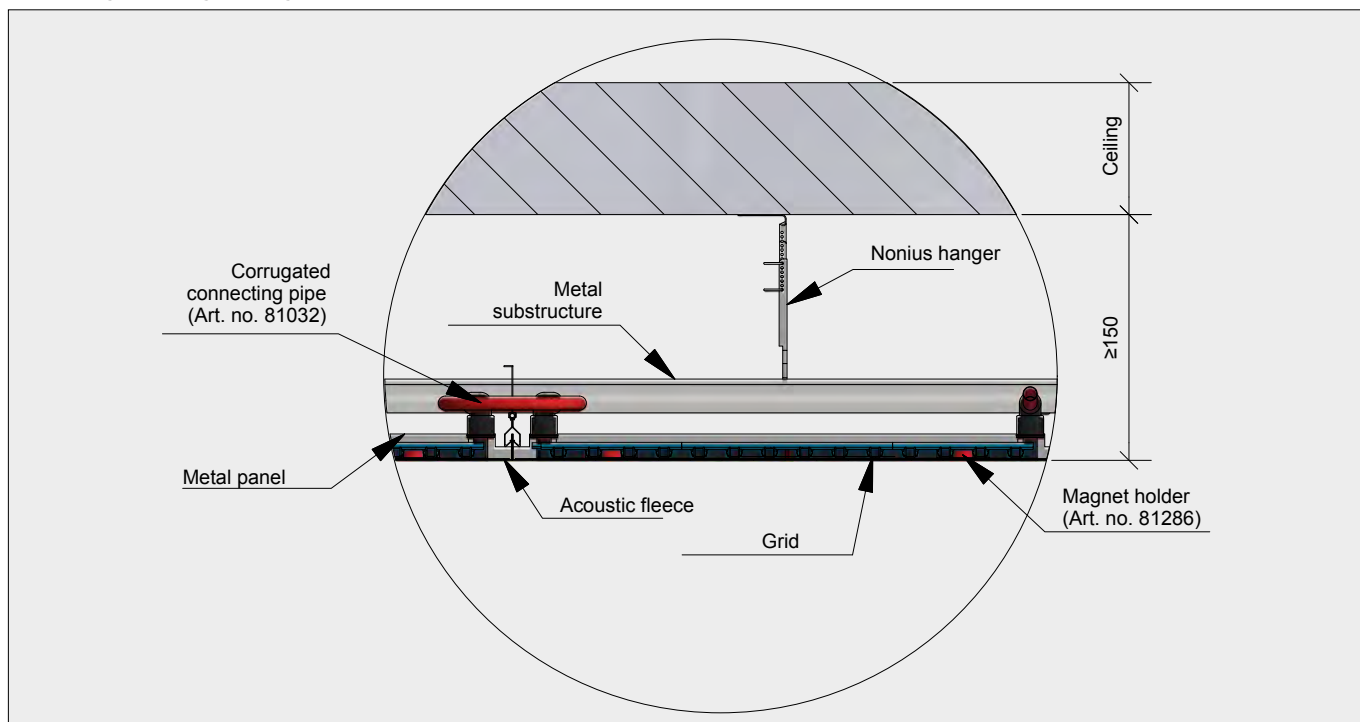

Detail: grid fixing ceiling

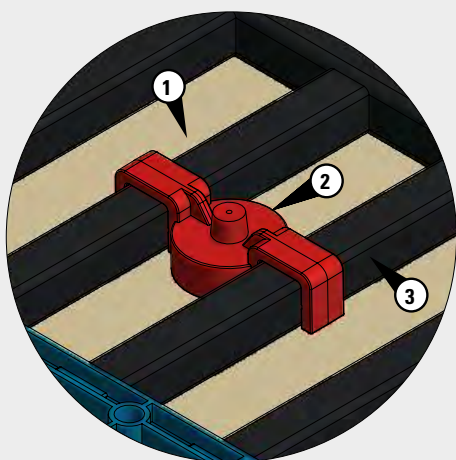

1. acoustic fleece
2. magnet holder (Art. no. 81286)
3. grid

Plastic grid attachment with magnet holder

After inserting the plastic grids are fixed with the magnet holders during ceiling installation.

Basically, the metal ceiling panels must always be fastened with at least 3 magnet holders. Whether additional magnets are required for the attachment, depends on the dimensions of the metal ceiling panel and the maximum distance between the magnets.

Maximum distance magnets: 0.8 m

Alternative fixing with magnets

Magnets per m ²	Grid area per m ²
3	from 0,00 to 0,50 m ²
4	from 0,51 to 1,00 m ²
5	from 1,01 to 5,00 m ²



Acoustic values of a standard metal ceiling

Description

The aquatherm black system grids for heating and cooling are inserted into the metal ceiling panels and fixed with magnet holders. A good power transmission is guaranteed due to the contact of the grid and metal plate.

Advantages

- High heating and cooling performance due to excellent contact transfer area
- Prefabricated grids for quick installation on site
- Very easy installation with magnet holders
- Combination with centrally conditioned outside air is possible
- Can be retrofitted in existing metal ceiling systems
- High sound absorption in metal ceiling panels with microperforation
- Installation in combination with various ceiling fixtures/structures such as lights, fire detectors and ventilation components
- Soundless and invisible heating and cooling

Sound absorption

Not only in office buildings the room acoustic is an important factor. A minimization of the sound propagation and thus a better speech intelligibility can be achieved by a high degree of sound absorption.

Acoustic values of a standard metal ceiling

Frequency (Hz)	125	250	500	1000	2000	4000
α_p	0,35	0,80	0,90	0,65	0,70	0,65
Sound absorption degree in metal ceiling system with proportional perforation type 2516						
Evaluation according to ISO 354						
Practical sound absorption coefficient according to ISO 11654						
$\alpha_w = 0,70(L)$						
Sound absorption class C						

Metal panel ceiling as clamping system - connection type 52

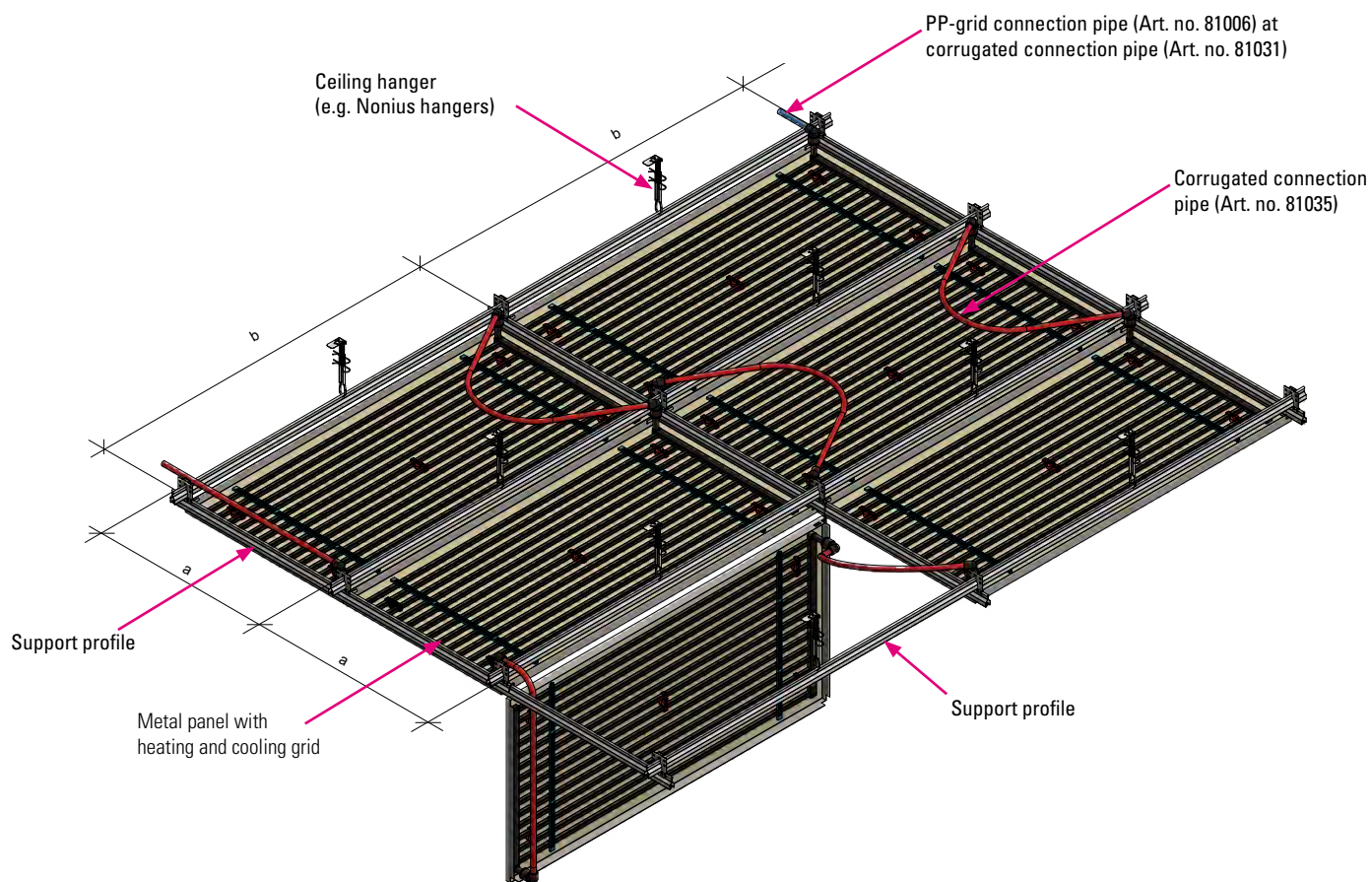

Planning data for ceiling grids		
Dimension metal panel (mm)		Grid (mm)
a	b	
600	1200	520 x 1100
625	1250	560 x 1180
Distances of the substructure according to manufacturer		
Special solutions on request		

Installation

1. Substructure

The substructure is accommodated invisibly in the ceiling cavity as a clamping system according to the manufacturer's specifications.

2. Assembly of the grids

For a smooth installation flow, the average drop height of the metal panel should be at least 15 cm. The grids, object-related and made to measure, are inserted in the panels and fixed with magnet holders according to the installation plan. Depending on the requirements a rock wool insulation (min. 30 mm), welded in a PE-film, can be laid on the grids.

3. Connection of the grids

The grids for the installation in a clamping system ceiling are supplied with 90° plug sockets (connection type 62) in one-sided design. After the installation of the metal clamping panels with integrated grids in the clamping rail, they are connected to heating or cooling zones according to the layout plan. For this purpose, prefabricated corrugated connecting pipes with 90° plug adapters are used. Ensure that the corrugated connection pipe is long enough so that the ceiling can be opened easily in the predetermined folding direction. The transition to the connecting supply is made by heating-socket-welding.

4. Installation of the clip-in panel ceiling

The mounting of the clamping panel ceiling must always follow the manufacturer's instructions. In principle, the heating/cooling system must be filled with water and pressurized.

Detail: connection piping between the grids

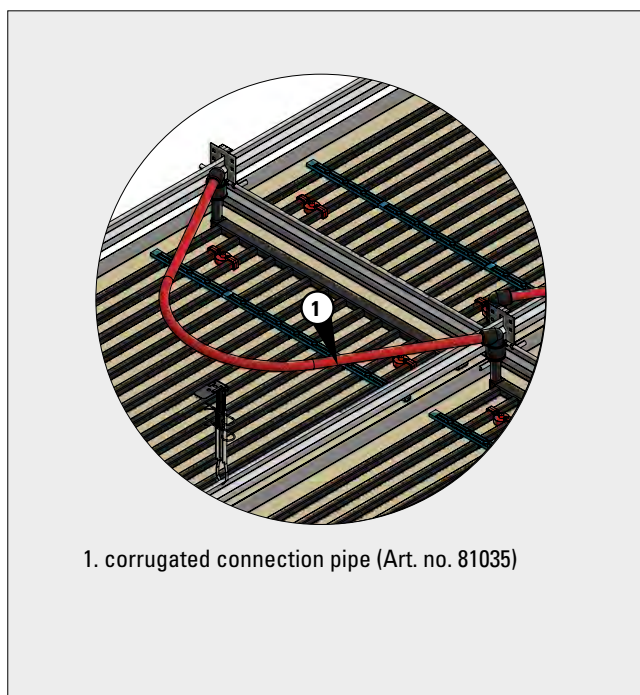

Metal panel ceiling as clamping system - connection type 52

Section: grid fixing ceiling

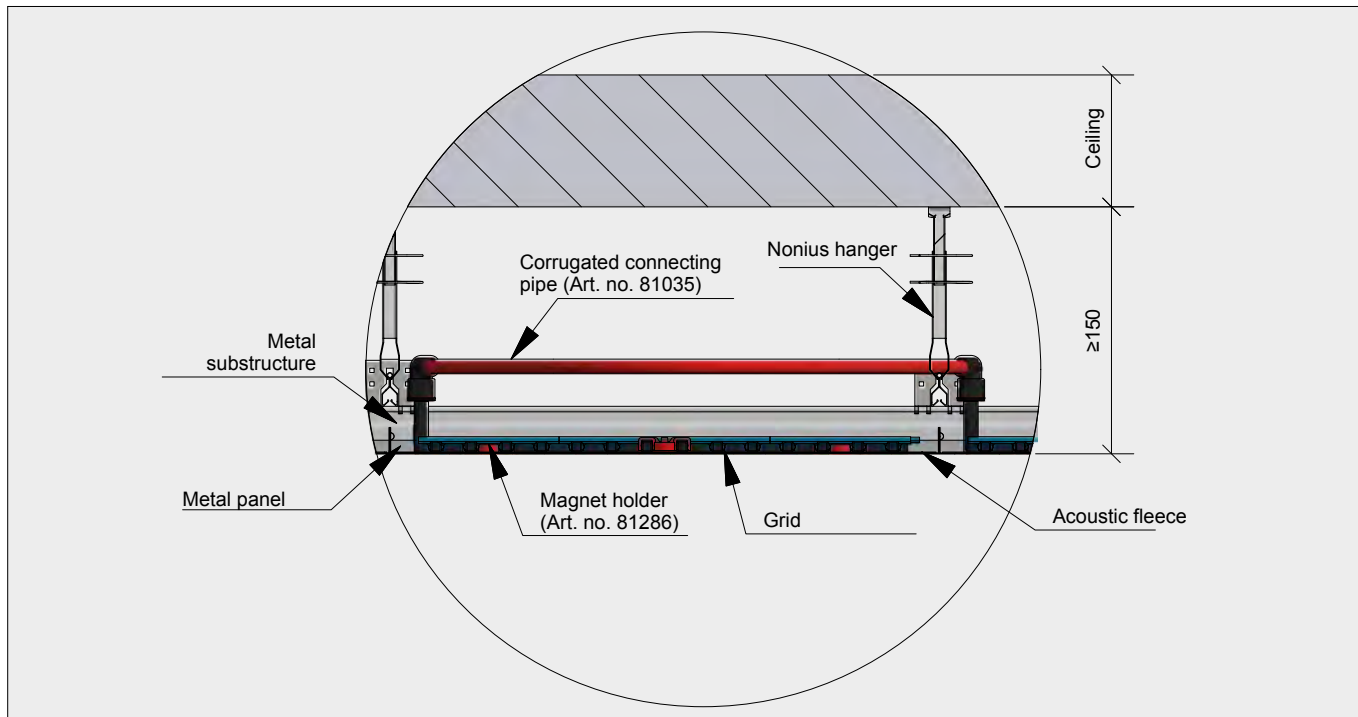

Detail: grid fixing

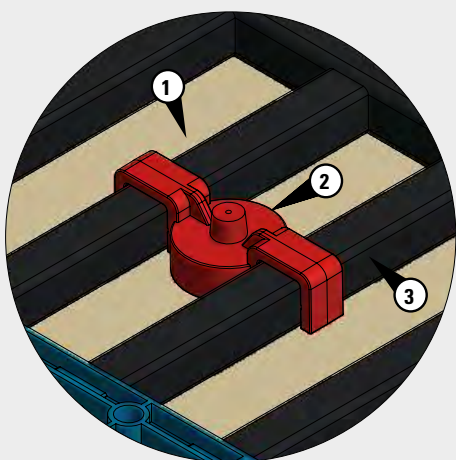

1. acoustic fleece
2. magnet holder (Art. no. 81286)
3. grid

Plastic grid attachment with magnet holder

After inserting the plastic grids are fixed with the magnet holders during ceiling installation.

Basically, the metal ceiling panels must always be fastened with at least 3 magnet holders. Whether additional magnets are required for the attachment, depends on the dimensions of the metal ceiling panel and the maximum distance between the magnets.

Maximum distance magnets: 0.8 m

Alternative fixing with magnets

Magnets per m ²	Grid area per m ²
3	from 0,00 to 0,50 m ²
4	from 0,51 to 1,00 m ²
5	from 1,01 to 5,00 m ²

Performance data metal panel ceiling as clamping system

ADVICE

With the aid of mechanical ventilation, convection is increased, so that an output increase is achieved especially with isothermal air supply.

Standard heating capacity according to DIN EN 14037-2

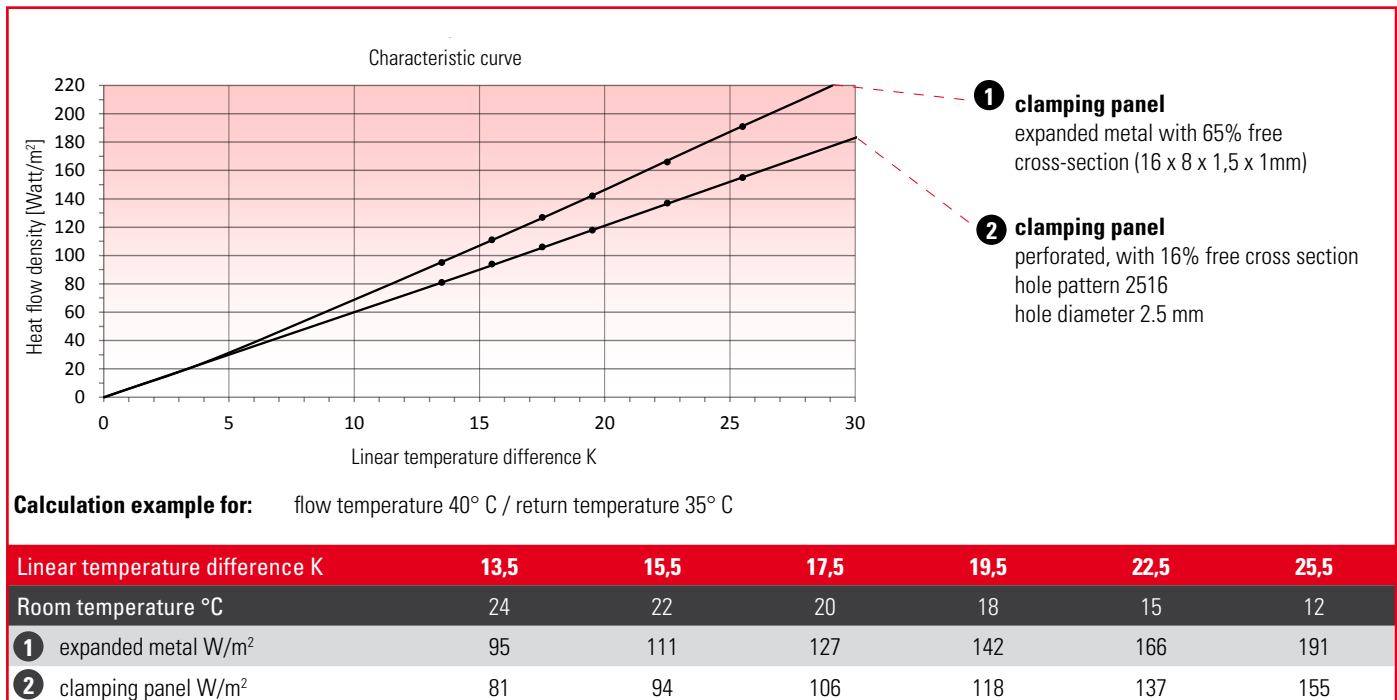

Standard cooling capacity according to DIN EN 14240: 2004-04

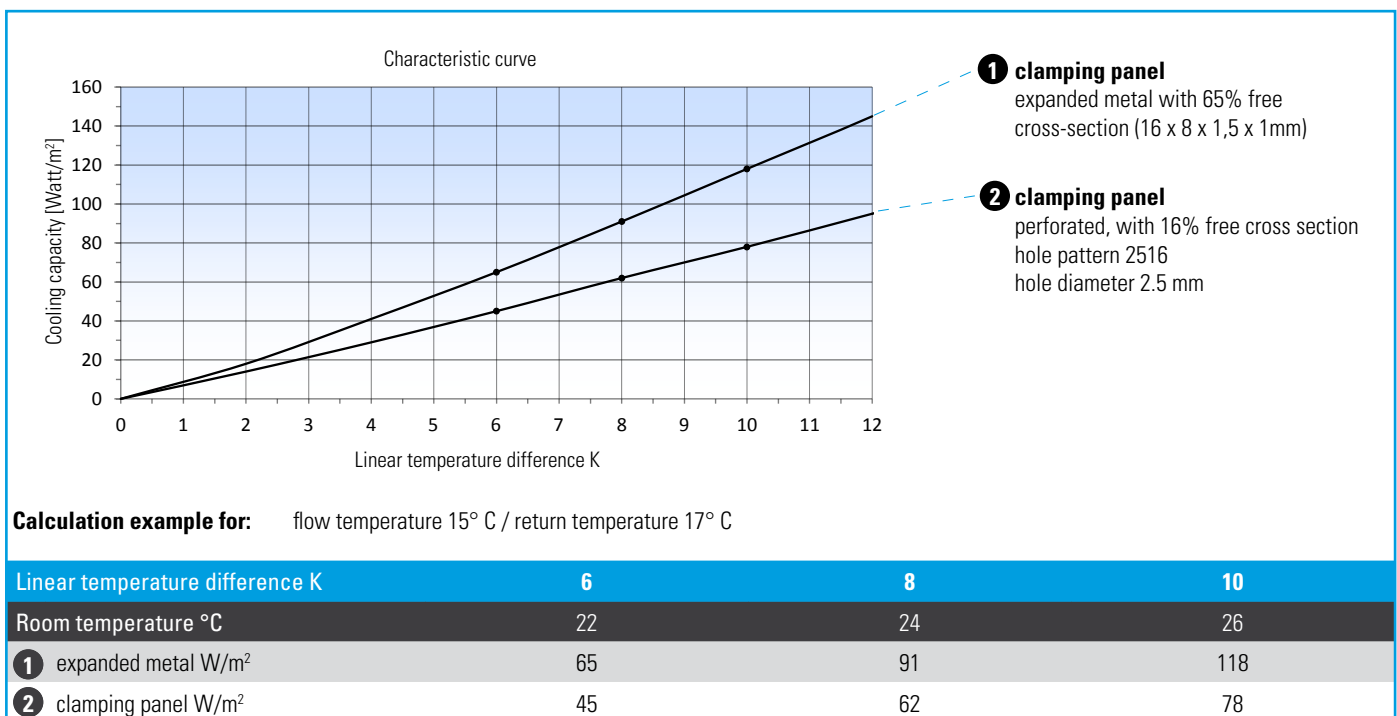



Metal panel ceiling as strip grid system

Description

The aquatherm black system grids for heating and cooling are inserted into the metal ceiling panels and fixed with magnet holders. A good power transmission is guaranteed due to the contact of the grid and metal plate.

Advantages

- High heating and cooling performance due to excellent contact transmission
- Prefabricated grids for quick assembly on site
- Easy installation with magnet holders
- Combination with centrally processed outside air is possible
- Ideally suited for use with heat pump and condensing boiler technology due to low flow and return temperatures
- Can be retrofitted in existing metal ceiling systems
- High sound absorption in metal ceiling panels with microperforation
- Installation in combination with various ceiling installation/superstructures such as lights, fire detectors and ventilation components
- Power output without drafts

Sound absorption

Not only in office buildings the room acoustic is an important factor. A minimization of the sound propagation and thus a better speech intelligibility can be achieved by a high degree of sound absorption.

Acoustic values of a metal ceiling

Frequency (Hz)	125	250	500	1000	2000	4000
α_p	0,35	0,80	0,90	0,65	0,70	0,65
Sound absorption degree in metal ceiling system with proportional perforation type 2516						
Evaluation according to ISO 354						
Practical sound absorption coefficient according to ISO 11654						
$\alpha_w = 0,70(L)$						
Sound absorption class C						

Metal panel ceiling as strip grid system - connection type 62

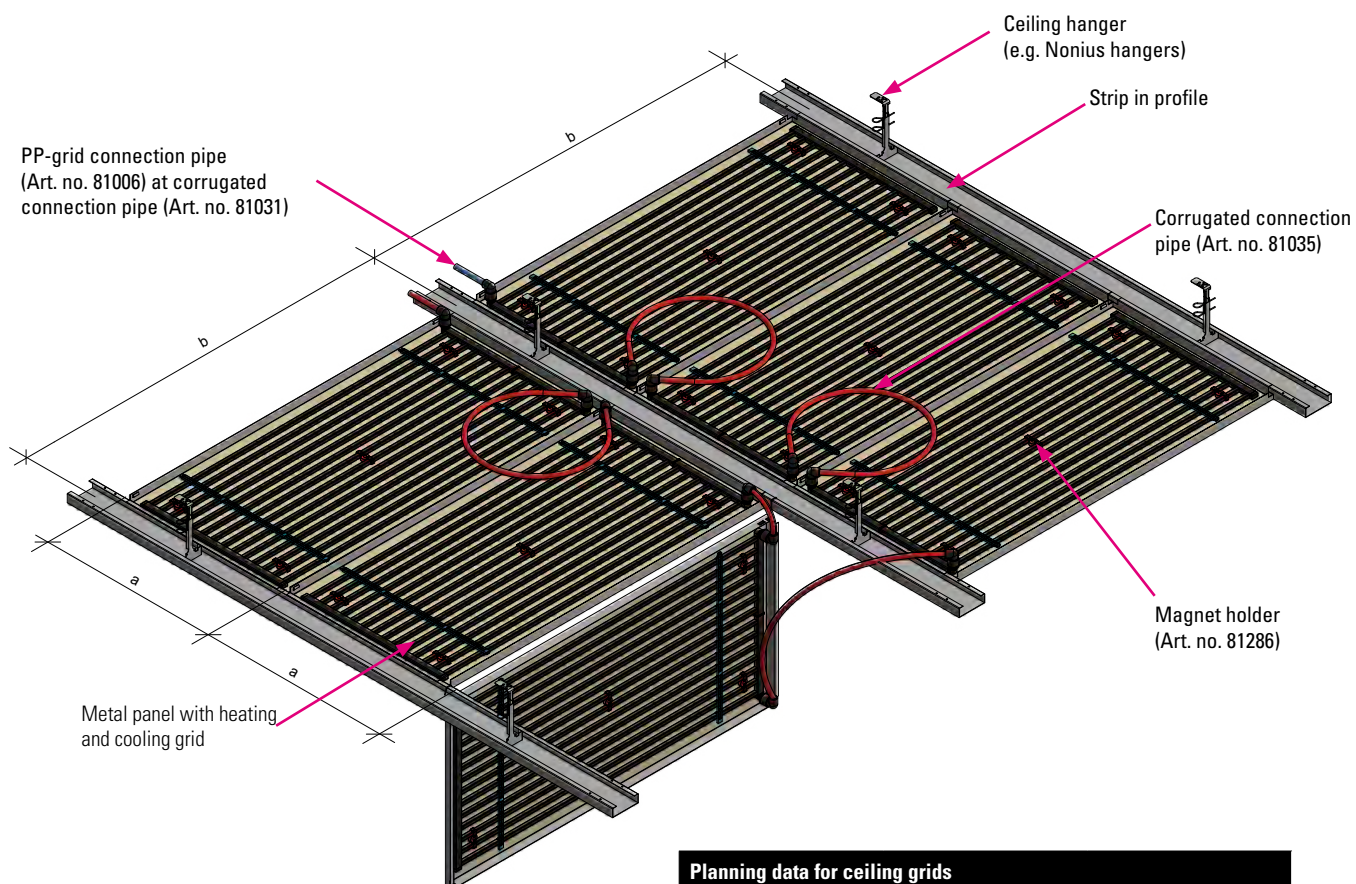

Installation

1. Substructure

The substructure is accommodated invisibly in the ceiling cavity as a strip grid system according to the manufacturer's specifications.

2. Assembly of the grids

For a smooth installation flow, the average drop height of the metal panel should be at least 15 cm. The grids, object-related and made to measure, are inserted in the panels and fixed with magnet holders according to the installation plan. Depending on the requirements a rock wool insulation (min. 30 mm), welded in a PE-film, can be laid on the grids.

3. Connection of the grids

The grids for the installation in a strip grid system ceiling are supplied with 90° plug sockets (connection type 62) in one-sided design. After the installation of the metal clamping panels with integrated grids in the clamping rail, they are connected to heating or cooling zones according to the layout plan. For this purpose, prefabricated corrugated connecting pipes with 90° plug adapters are used. Ensure that the corrugated connection pipe is long enough so that the ceiling can be opened easily in the predetermined folding direction. The transition to the connecting supply is made by heating-socket-welding.

The connection of the heating respectively cooling circuits at the distributor or the main supply is made with aquatherm black system PP grid pipe 16 x 2 mm or alternative connection systems (e.g. aquatherm grey pipe).

4. Installation of the clamping panel ceiling

The mounting of the strip grid system ceiling must always follow the manufacturer's instructions. In principle, the heating/cooling system must be filled with water and pressurized.

Planning data for ceiling grids

Dimension metal panel (mm)		Grid (mm)
a	b	
600	1200	520 x 1100
625	1250	560 x 1180
Distances of the substructure according to manufacturer		
Special solutions on request		

Detail: Cross strip in system

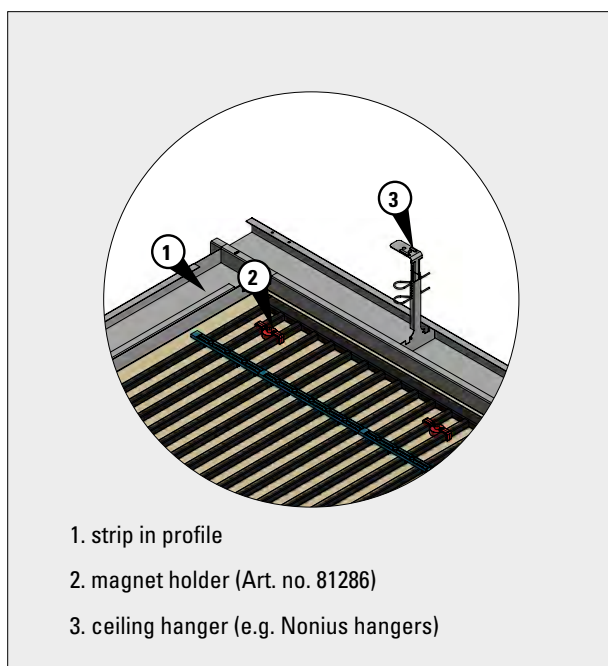

1. strip in profile
2. magnet holder (Art. no. 81286)
3. ceiling hanger (e.g. Nonius hangers)

Metal panel ceiling as strip grid system - connection type 62

Section: grid fixing ceiling

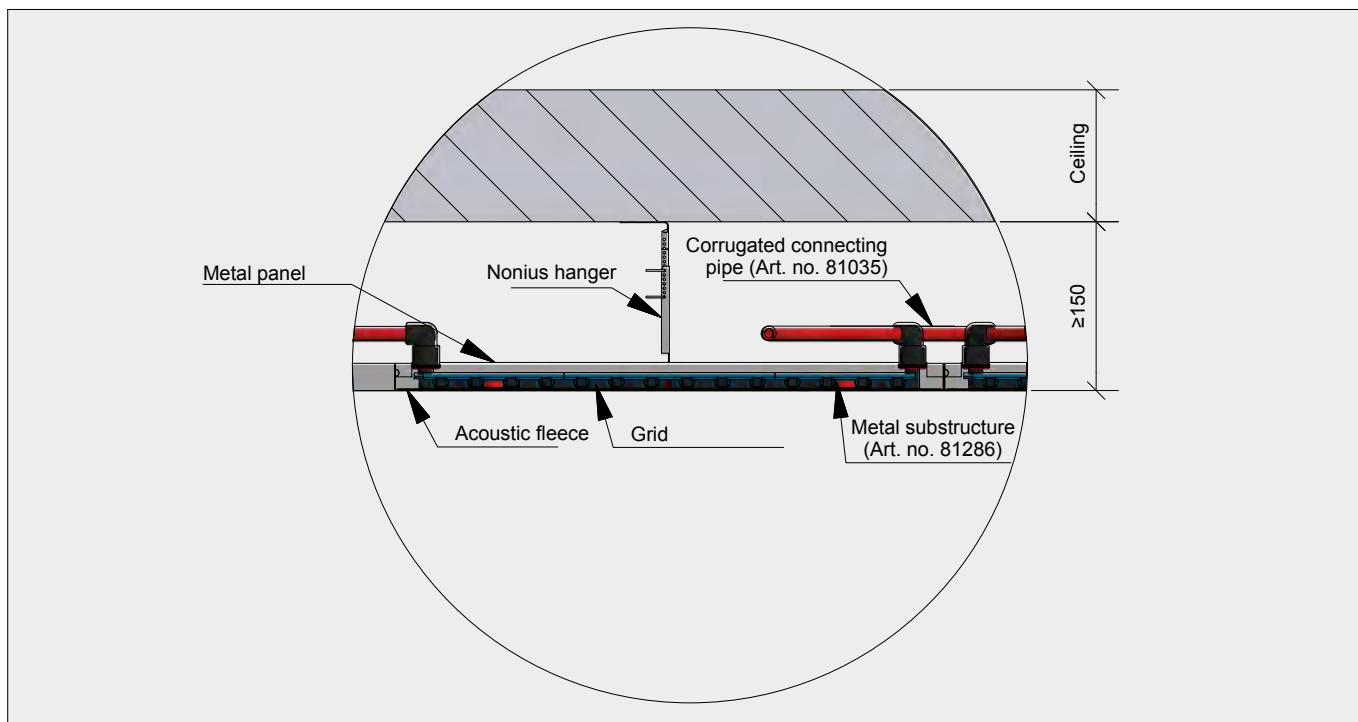

Detail: Connection piping between the grids

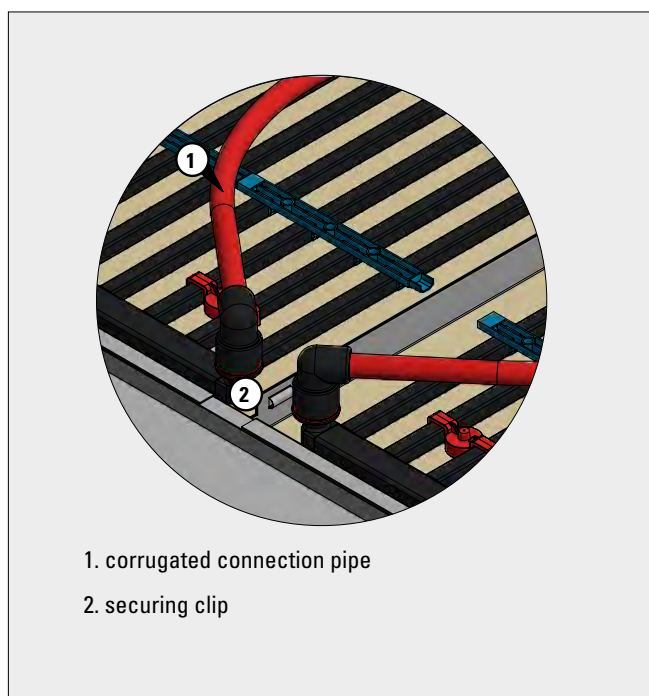

Detail: grid fixing in metal panel

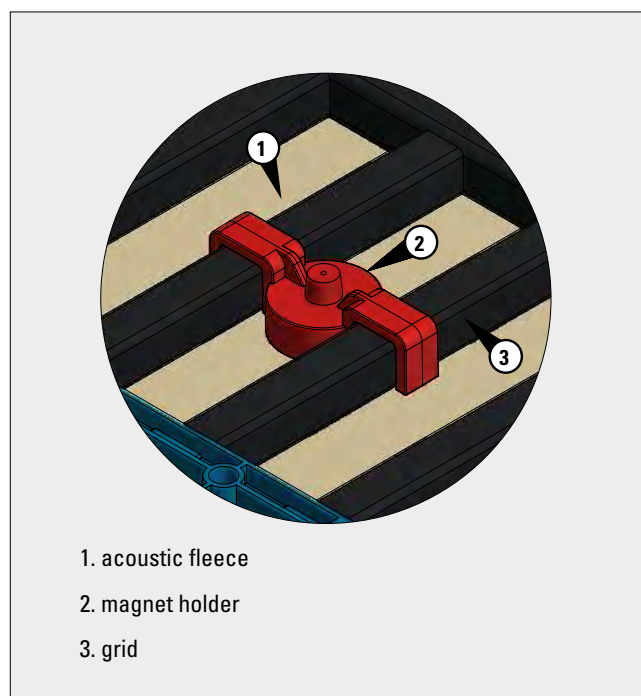

Alternative fixing with magnets

Magnets per m ²	Grid area per m ²
3	from 0,00 to 0,50 m ²
4	from 0,51 to 1,00 m ²
5	from 1,01 to 5,00 m ²

Performance data metal panel ceiling as strip in system

ADVICE

With the aid of mechanical ventilation, convection is increased, so that an output increase is achieved especially with isothermal air supply

Standard heating performance according to DIN EN 14037-2

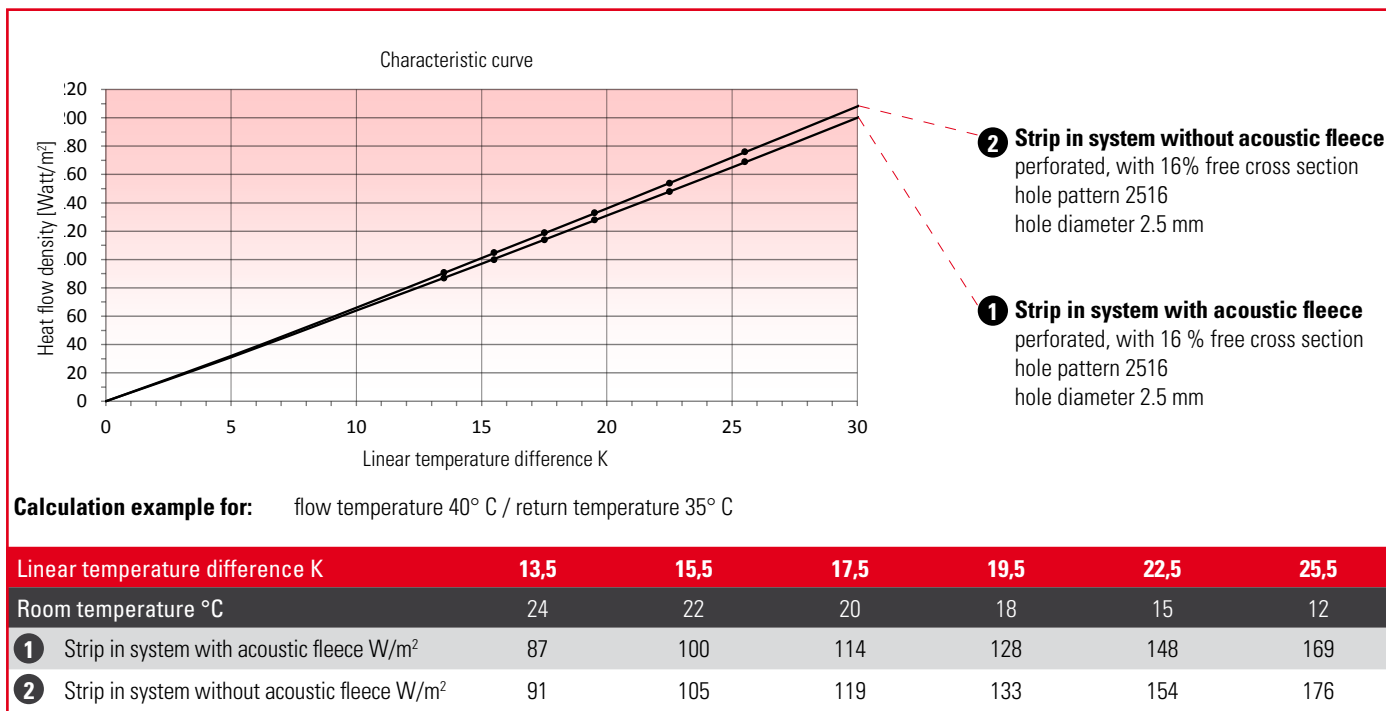

Standard cooling capacity according to DIN EN 14240: 2004-04

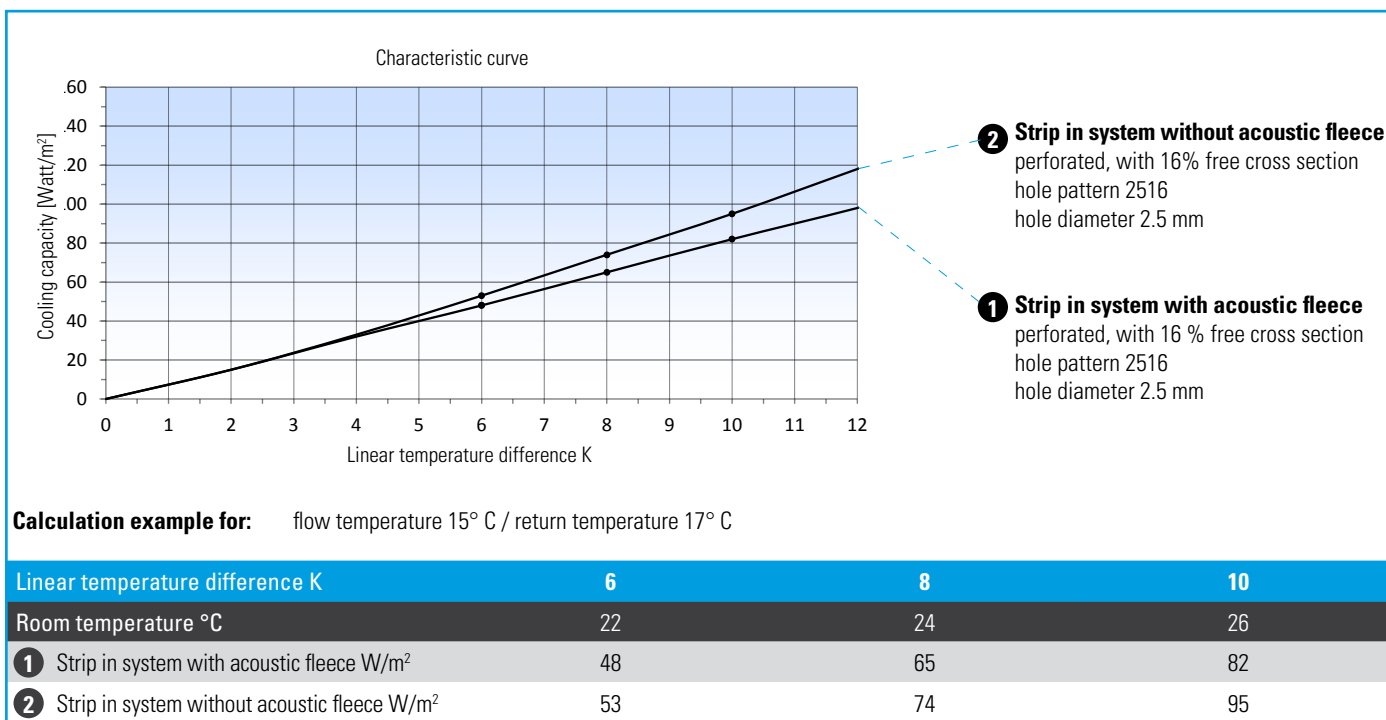



Ceiling system with metal insertion plates

Description

Installation is quick and easy: the aquatherm black system grids are placed on the metal insertion plates and fixed with magnet holders. The direct contact of the grids to the insertion plates ensures good power transmission.

Advantages

- High heating and cooling performance due to excellent contact transmission with the insertion plates
- Prefabricated grids for quick assembly on site
- Ideally suited for use with heat pump and condensing boiler technology due to low flow and return temperatures
- Can be retrofitted in existing metal ceiling systems
- High sound absorption in ceiling panels with perforation and acoustic fleece
- Installation in combination with various ceiling installation/superstructures such as lights, fire detectors and ventilation components
- Power output without drafts
- Soundless and invisible heating and cooling

Sound absorption

Not only in office buildings the room acoustic is an important factor. A minimization of the sound propagation and thus a better speech intelligibility can be achieved by a high degree of sound absorption.

Acoustic values of a standard metal ceiling

Frequency (Hz)	125	250	500	1000	2000	4000
α_p	0,35	0,80	0,90	0,65	0,70	0,65
Sound absorption degree in metal ceiling system with proportional perforation type						
Evaluation according to ISO 354						
Practical sound absorption coefficient according to ISO 11654						
$\alpha_w = 0,70(L)$						
Sound absorption class C						

Ceiling system with metal insertion plates - connection type 62

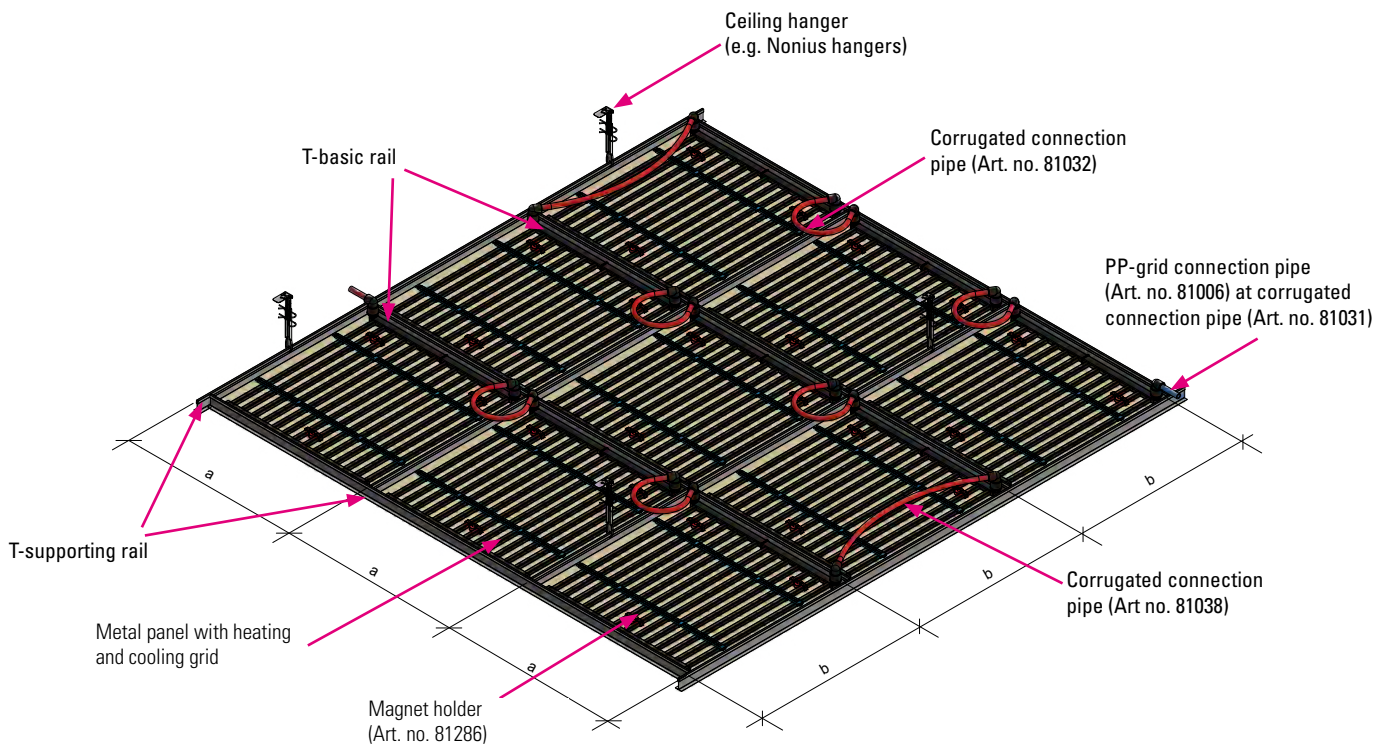

Planning data for ceiling grids		
Dimension metal panel (mm)		Grid (mm)
a	b	520 x 560
600	600	520 x 560
625	625	560 x 600
Distances of the substructure according to manufacturer		
Special solutions on request		

Installation

1. Substructure

The substructure is fastened and aligned to the raw ceiling by the drywall builder according to the manufacturer's specifications. If there is a substructure, only the suitability of the selected insertion plates must be checked.

2. Assembly of the grids

For a smooth installation flow, the average drop height of the system with insertion plates should be at least 15 cm. The grids, made to measure, are placed on the insertion plates and fixed with magnet holders according to the installation plan (see page 59). Depending on the requirements a rock wool insulation (min. 30 mm), welded in a PE-film, can be laid on the grids.

3. Connection of the grids

The grids for the installation in a ceiling system for insertion plates are equipped with plug sockets, connection type 62 (one-sided). After mounting the grids on the insertion plates, they are connected to heating or cooling zones according to the installation plan. The aquatherm black system corrugated connecting pipe is used for this (see detail of connection piping).

4. Installation of the clamping panel ceiling

The mounting of the ceiling system with insertion plates must always follow the manufacturer's instructions. In principle, the heating/cooling system must be filled with water and pressurized.

Detail: connection piping between the grids

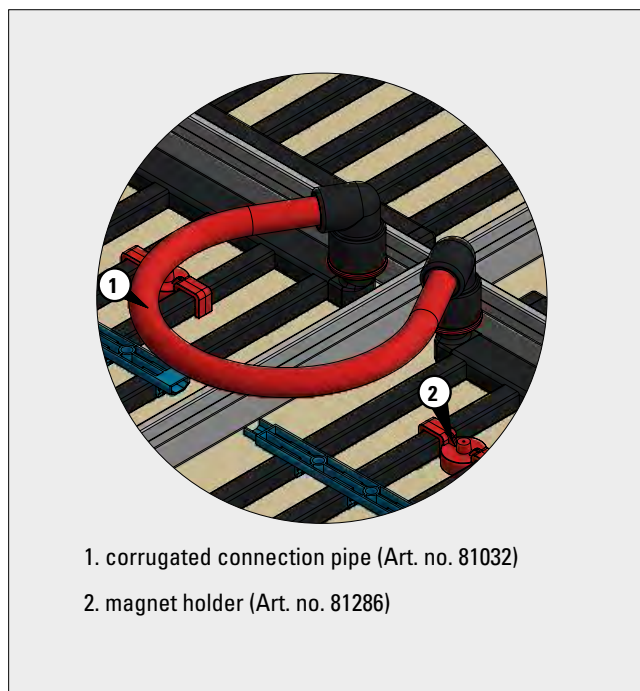

1. corrugated connection pipe (Art. no. 81032)
2. magnet holder (Art. no. 81286)

Ceiling system with metal insertion plates - connection type 62

Section: grid fixing ceiling

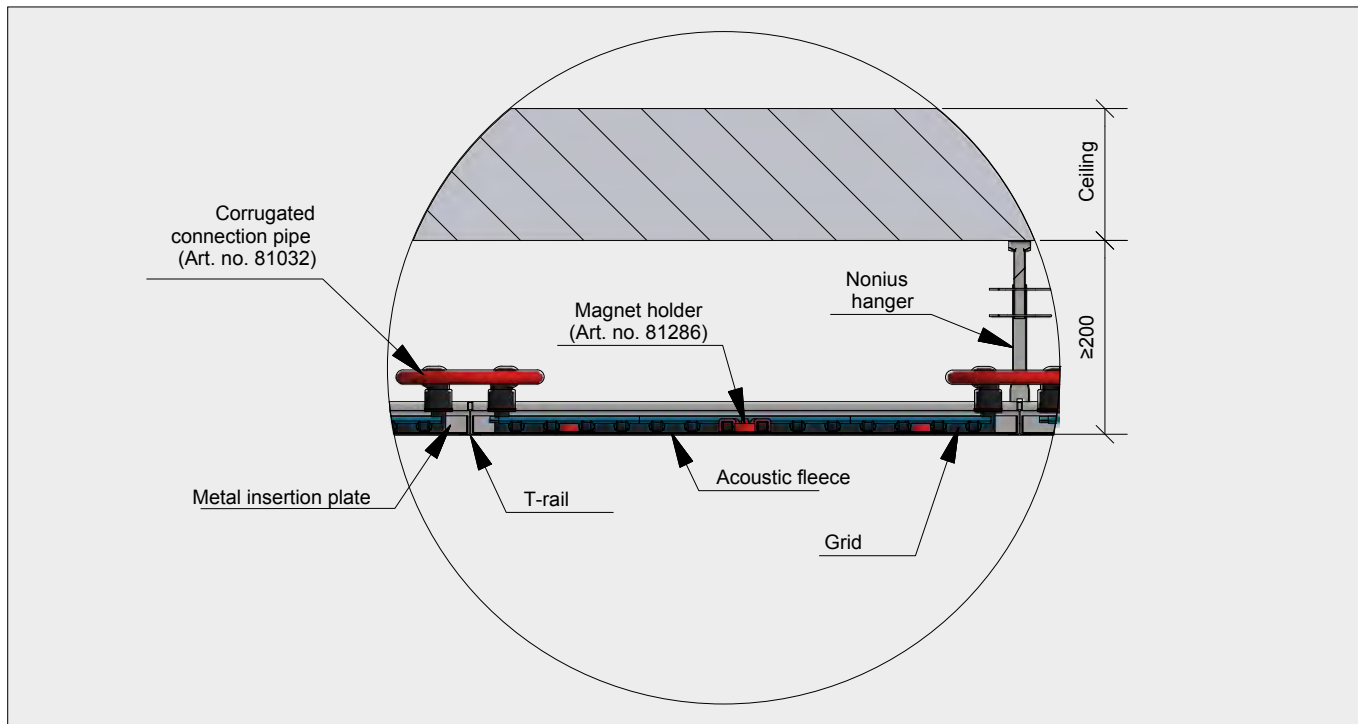

Installation examples of additional insertion plates for standard T-rails:

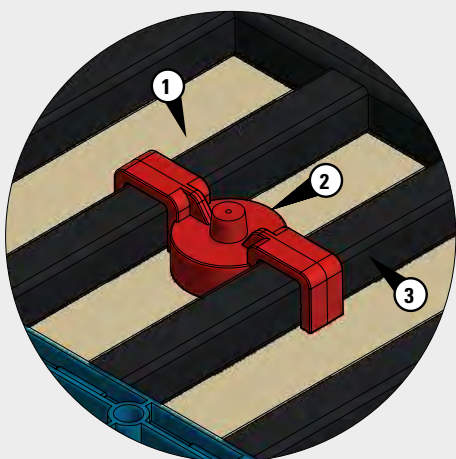
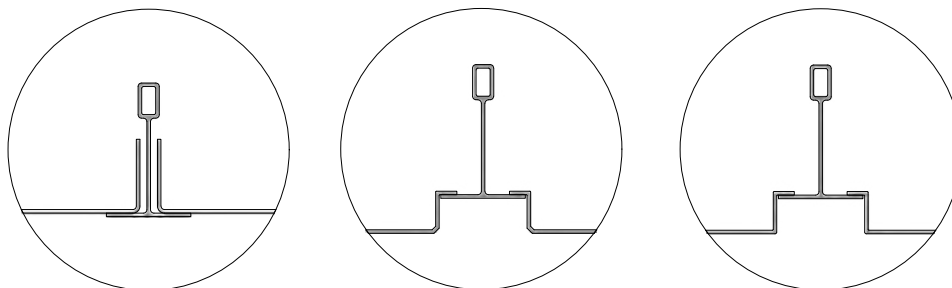

1. acoustic fleece
2. magnet holder (Art. no. 81286)
3. grid

Plastic grid attachment with magnet holder

After inserting the plastic grids are fixed with the magnet holders during ceiling installation.

Basically, the metal ceiling panels must always be fastened with at least 3 magnet holders. Whether additional magnets are required for the attachment, depends on the dimensions of the metal ceiling panel and the maximum distance between the magnets.

Maximum distance magnets: 0.8 m

Alternative fixing with magnets

Magnets per m ²	Grid area per m ²
3	from 0,00 to 0,50 m ²
4	from 0,51 to 1,00 m ²
5	from 1,01 to 5,00 m ²

Performance data ceiling system with metal insertion plates

ADVICE

With the aid of mechanical ventilation, convection is increased, so that an output increase is achieved especially with isothermal air supply

Standard **heating performance** according to DIN EN 14037-2

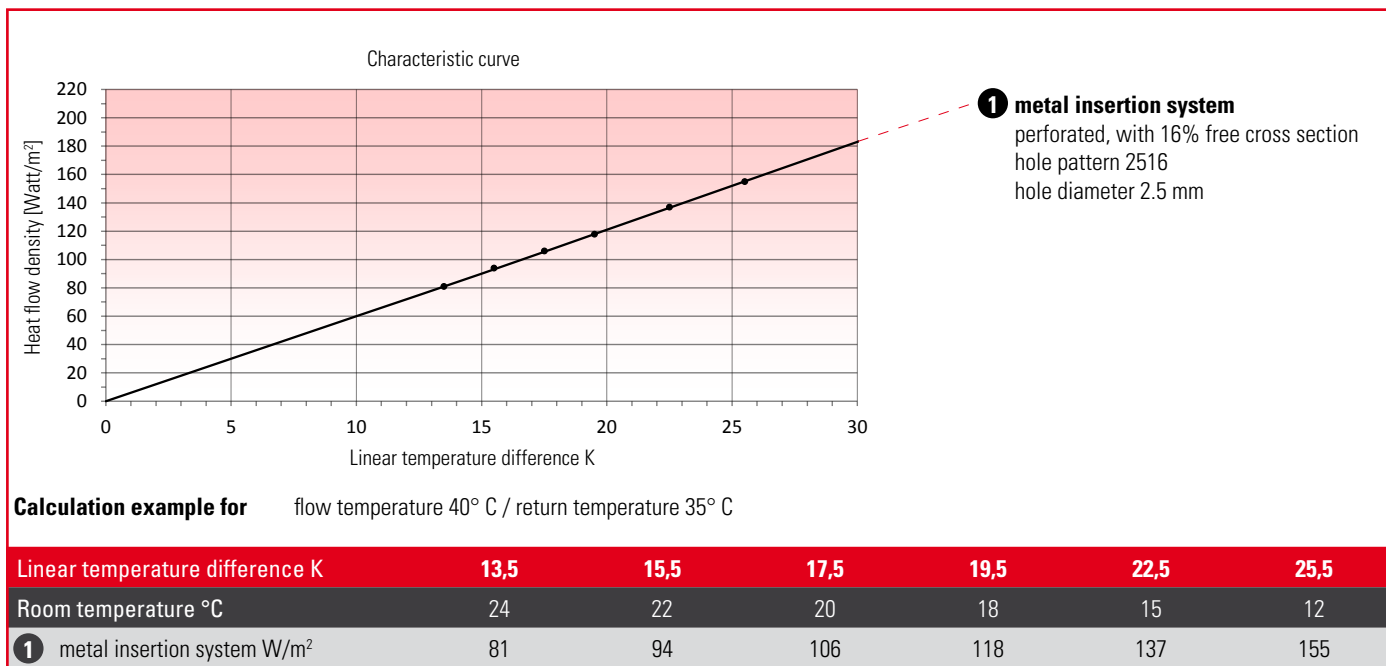

Standard **cooling capacity** according to DIN EN 14240: 2004-04

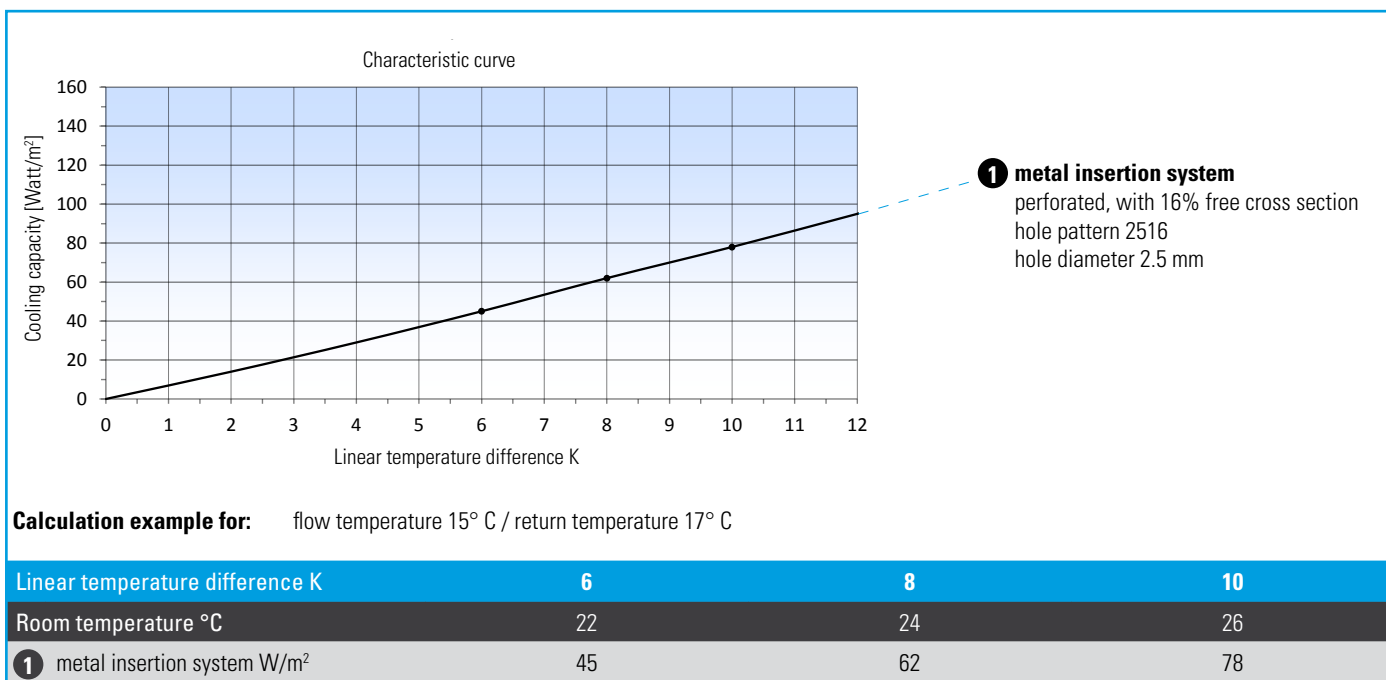



Thermal active ceiling sail

Description

Metal ceiling sails offer the greatest possible freedom of design for architects and planners: Both, the sails and the aquatherm black system can be individually adapted in shape and size to any room geometry. aquatherm black system grids are ideal for the quick and even distribution of heat and cold in the surface. An innovative material combines high thermal conductivity with minimal weight.

Advantages

- High heating and cooling performance due to excellent contact transmission surface
- Prefabricated grids for quick assembly on site
- Very easy installation with magnet holders
- Combination with centrally conditioned outside air is possible
- Can be retrofitted in existing metal ceiling sails
- High sound absorption with metal ceiling sails with microperforation
- Power output without drafts
- Soundless and non-visible heating and cooling

Sound absorption

To improve the room acoustics, acoustic fleeces are glued to the perforated cooling ceiling sail. With an acoustic ceiling covering (mineral wool shrik wrapped in foil) better sound absorption values are achieved.

Acoustic values of a metal ceiling sail

Frequency (Hz)	125	250	500	1000	2000	4000
α_p	0,70	2,00	2,60	2,00	2,20	2,10
Sound absorption degree in metal ceiling system with proportional perforation type 2516, hole share 16%						
Evaluation according to ISO 354						
Practical sound absorption coefficient according to ISO 11654						
$\alpha_w = 0,70(L)$						
Sound absorption class C						

The ceiling sails were raised with 150 mm columns on a reverberation floor.

Equivalent sound absorption area (500 Hz) = 2.6 m²

Thermal active ceiling sail - connection type 62

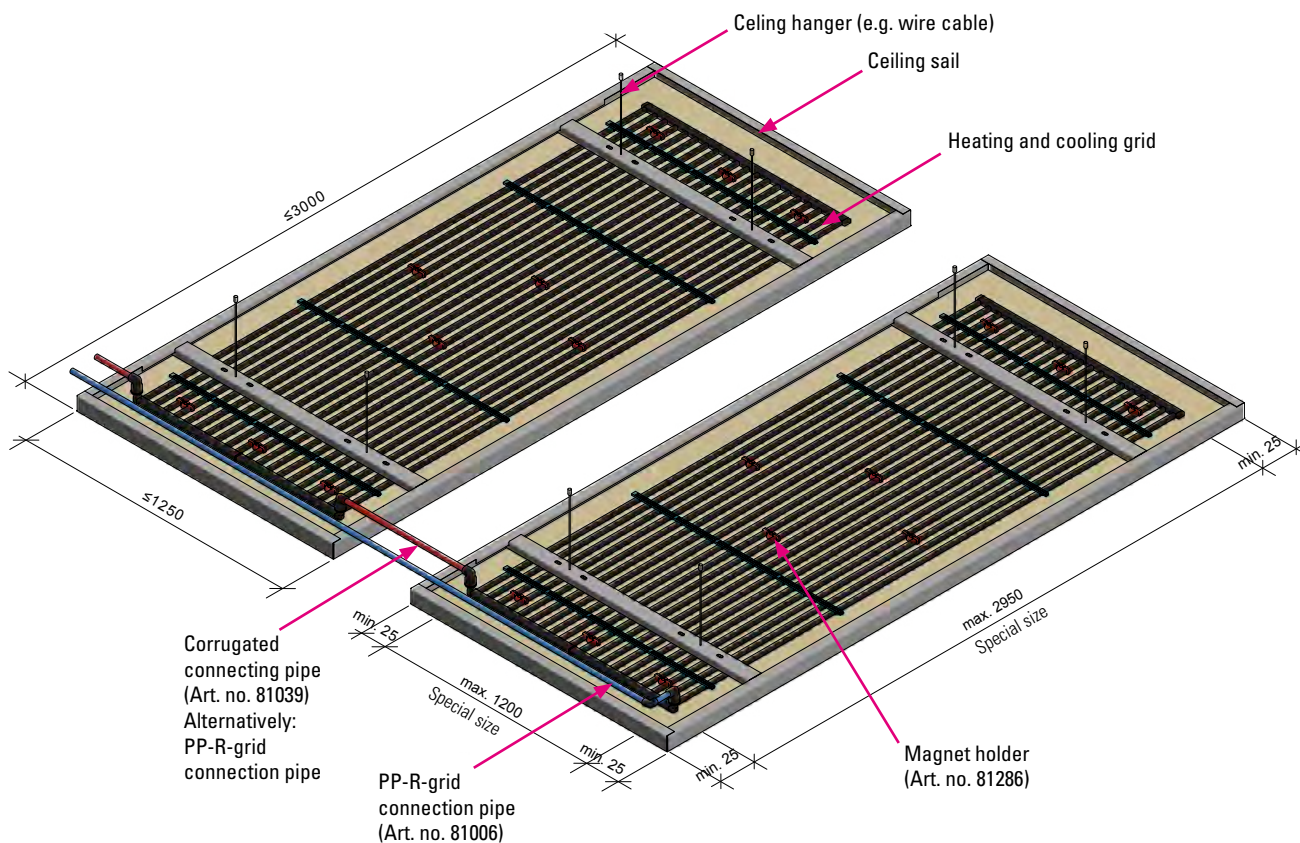

Special solutions on request

Processing instruction

1. Connection of the grids

The grids for the installation in a ceiling sail are delivered with one-side plug socket 90° with flow break. Thus, a constant flow is guaranteed, and the grids can be connected one-sided. After hanging the grids in the metal ceiling sail at the ceiling they are interconnected to heating or cooling zones according to the layout plan. Therefore, the prefabricated corrugated connecting pipes with 90° plug adapters are used. The transition to the connecting pipe is carried out by means of heating-socket-welding.

Detail: connection piping between the grids

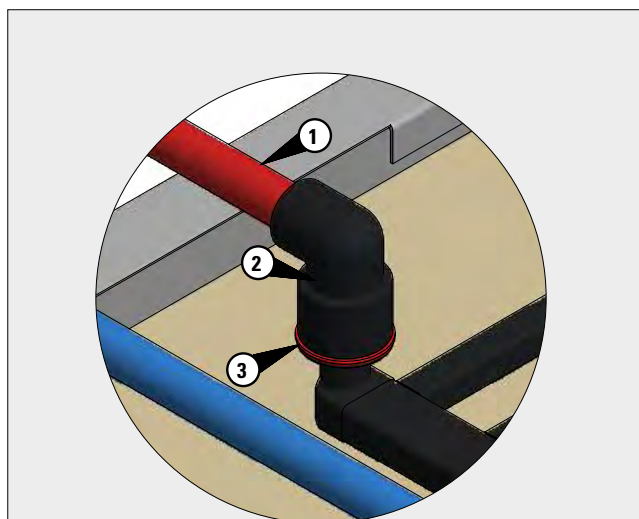

1. Corrugated connection pipe (Art. no. 81039)
Alternatively: PP-R-grid connection pipe (Art. no. 81006)
2. 90° plug elbow adapter (Art. no. 81290)
3. securing clip

Thermal active ceiling sail - connection type 62

Section: grid fixing ceiling

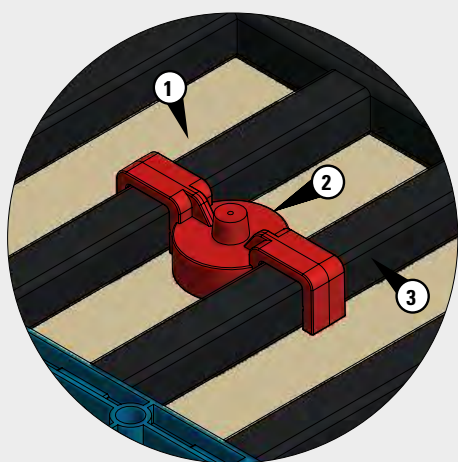
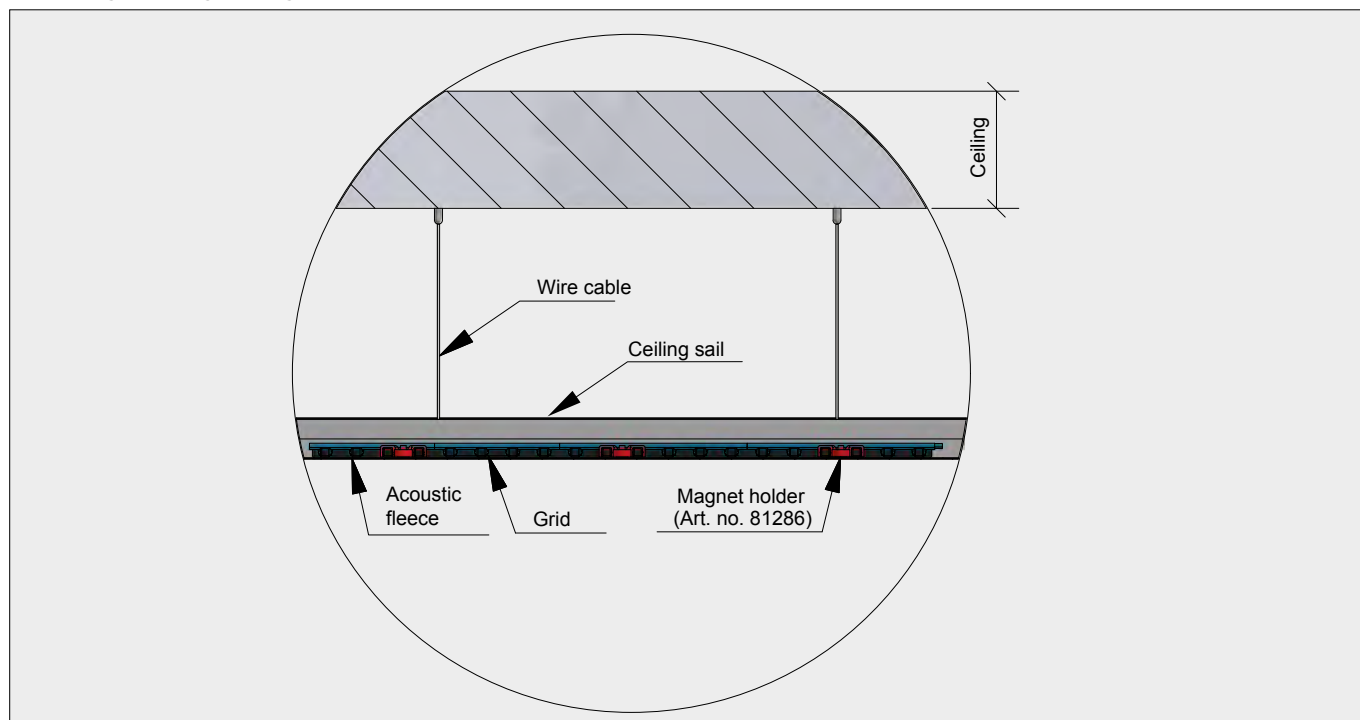

1. acoustic fleece
2. magnet holder (Art. no. 81286)
3. grid

Plastic grid attachment with magnet holder

After inserting the plastic grids are fixed with the magnet holders during ceiling installation.

Basically, the metal ceiling panels must always be fastened with at least 3 magnet holders. Whether additional magnets are required for the attachment, depends on the dimensions of the metal ceiling panel and the maximum distance between the magnets.

Maximum distance magnets: 0.8 m

Alternative fixing with magnets

Magnets per m ²	Grid area per m ²
3	from 0,00 to 0,50 m ²
4	from 0,51 to 1,00 m ²
5	from 1,01 to 5,00 m ²

Performance data thermal active ceiling sail - connection type 62

ADVICE

With the aid of mechanical ventilation, convection is increased, so that an output increase is achieved especially with isothermal air supply

Standard **heating performance** according to DIN EN 14037-2

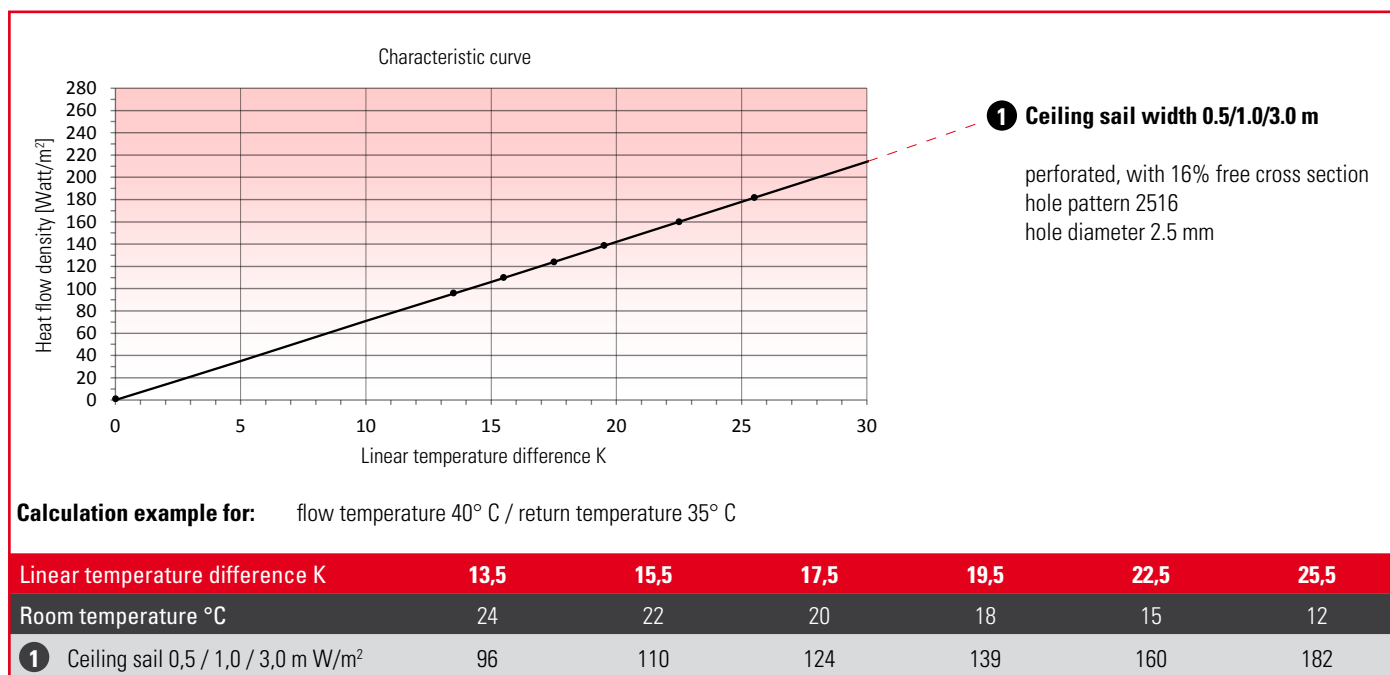

Standard **cooling capacity** according to DIN EN 14240: 2004-04

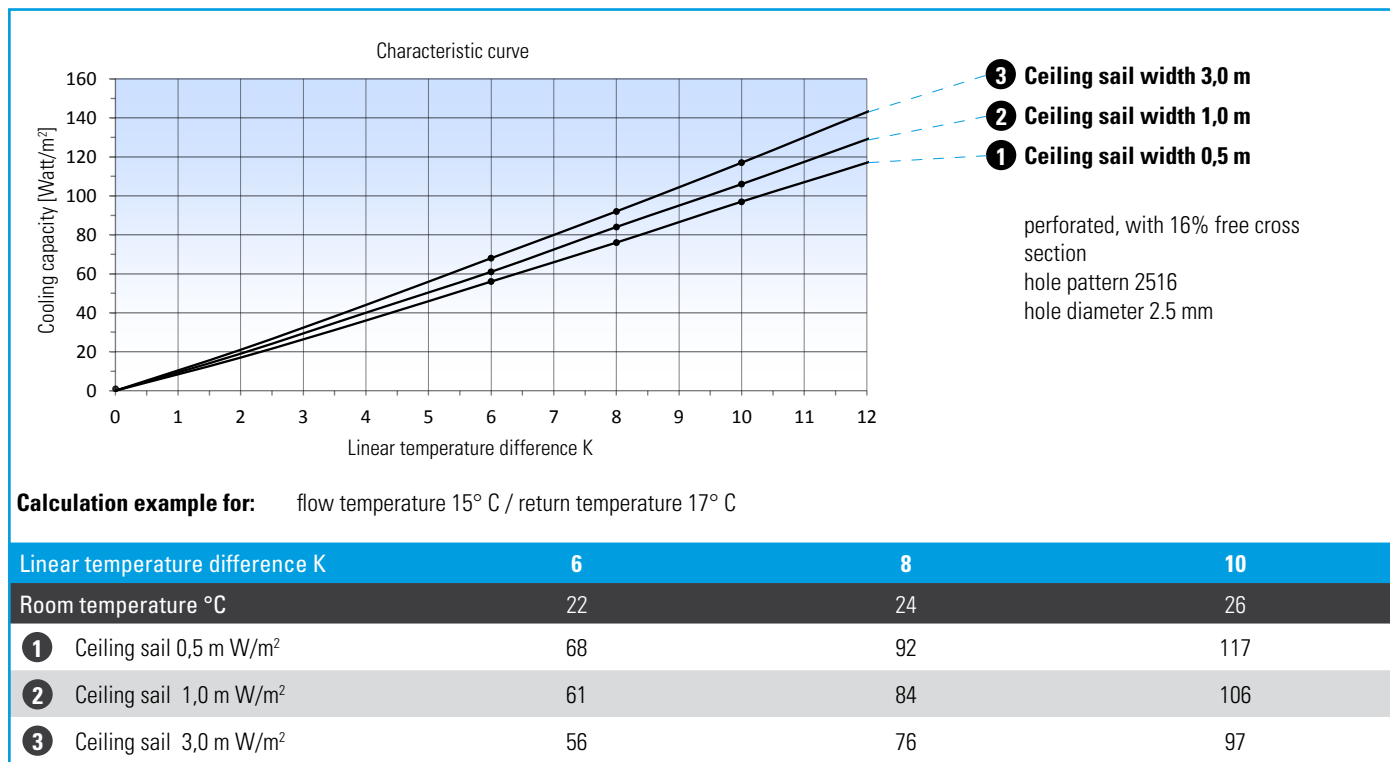



Free convection – suspended

Description

The heating and cooling grids are laying on a permeable substructure, which allows unrestricted air circulation. The aquatherm black system grids are placed on the substructure and fixed, if necessary. The system is characterized by a high level of performance. It is used, for example, for the heating of single workstations in industry.

Advantages

- *High heating and cooling performance due to free convection*
- *The system can be used variably*
- *Combination with other ceiling substructures, such as lighting, fired detectors, sprinklers and ventilation components*

Free convection – suspended

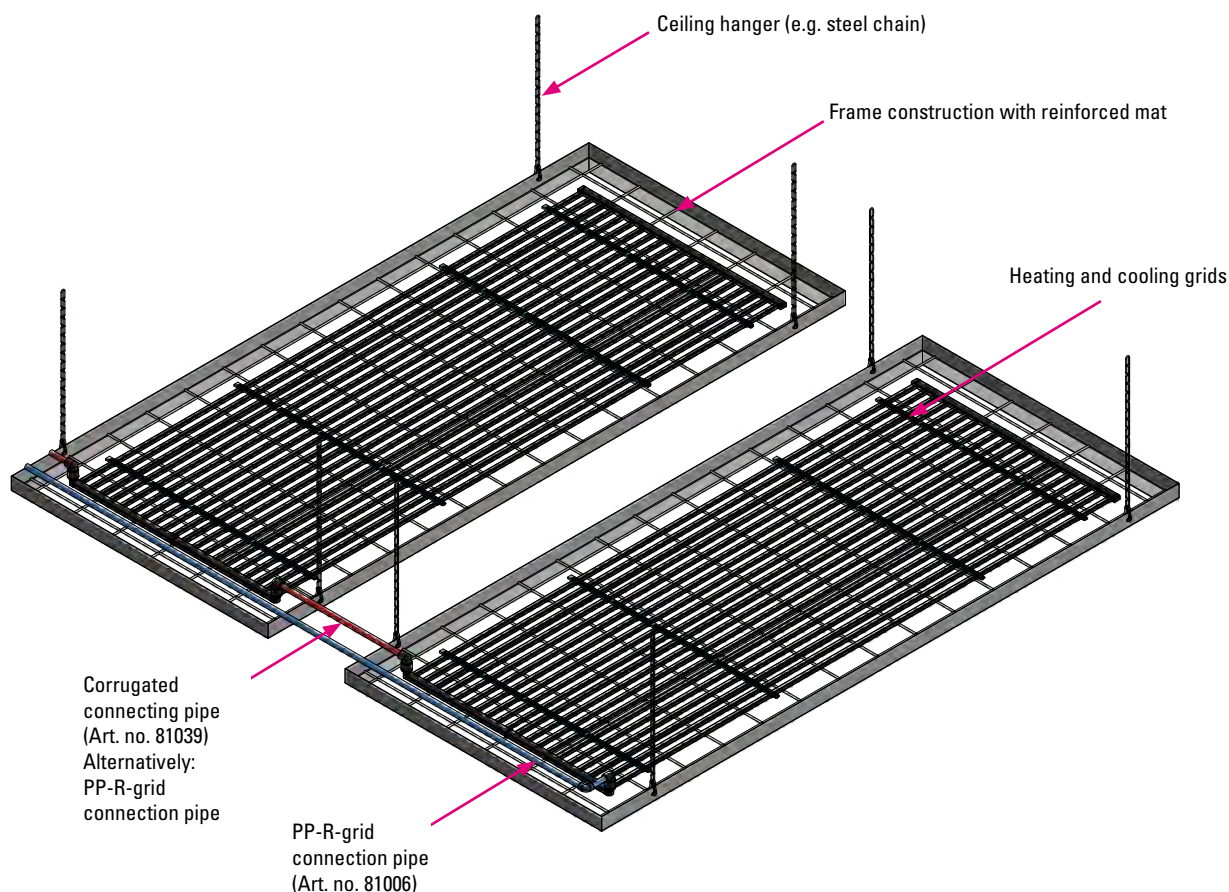

Description

1. Substructure

The substructure for free convection is suspended from the ceiling with suitable hangers (e. g. steel chains).

2. Assembly of grids

For a smooth installation flow, the average drop height of the substructure should be at least 15 cm. The grids, object-related and made to measure, are placed and fixed according to the installation plan.

3. Connection of the grids

The grids for free convection are supplied with 90° plug connection (connection type 62) in one-sided design. After installation on the substructure, they are connected to heating and cooling zones according to installation plan. For this, prefabricated corrugated connection pipes or optional connection pipes are used.

Basically, the heating/cooling system must be filled with water and pressed off.

Detail: connection piping between the grids

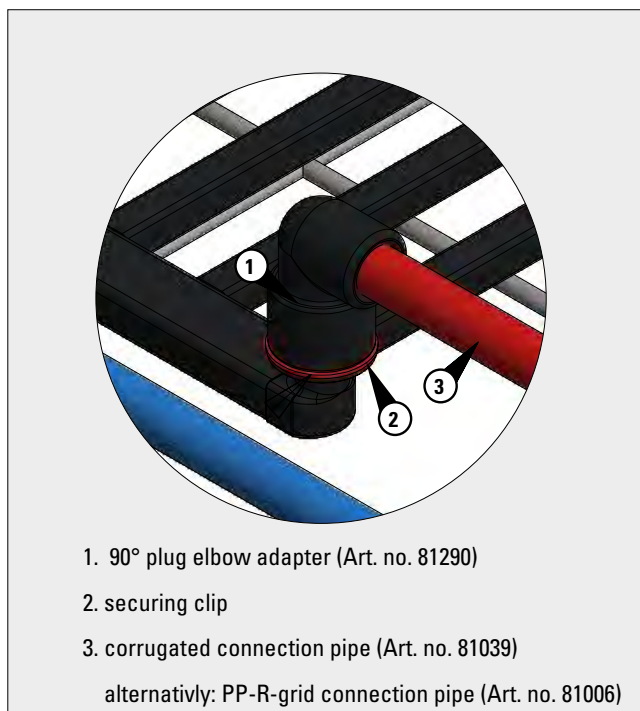

Free convection – suspended

Section: grid fixing ceiling

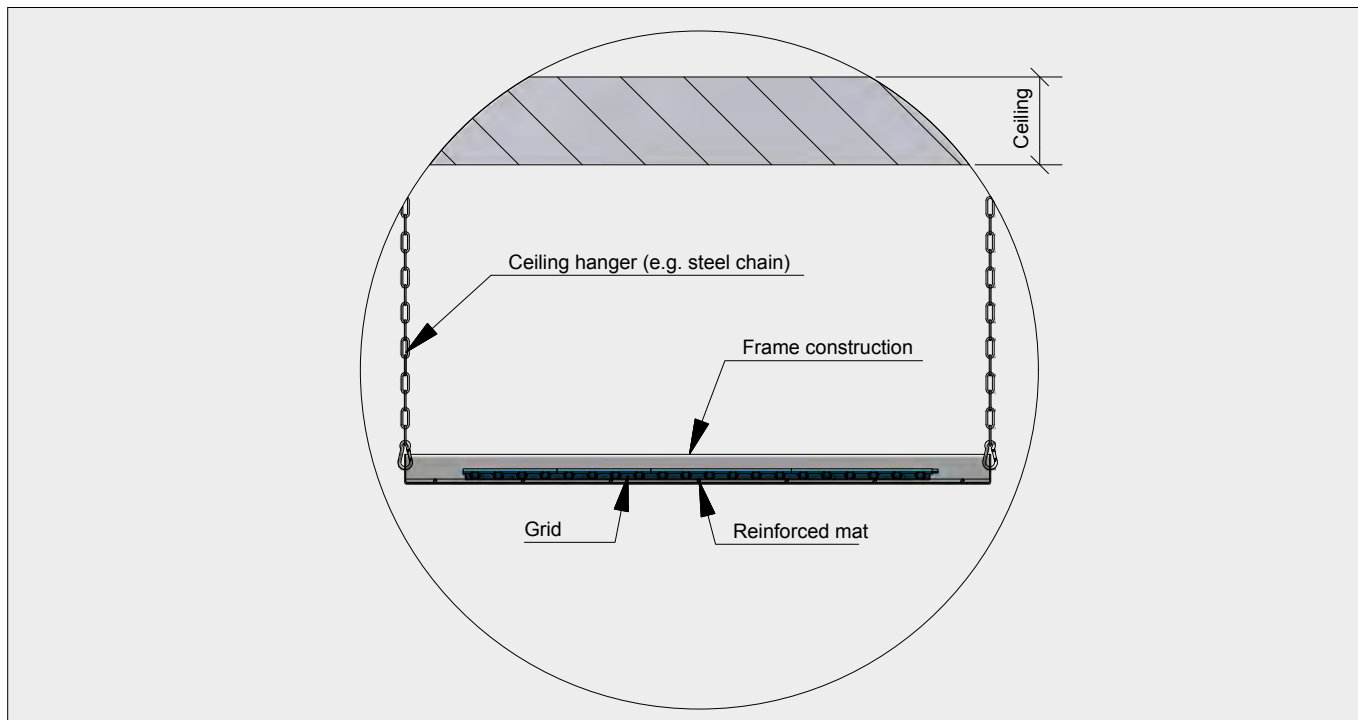

Detail: alternative bearing surface

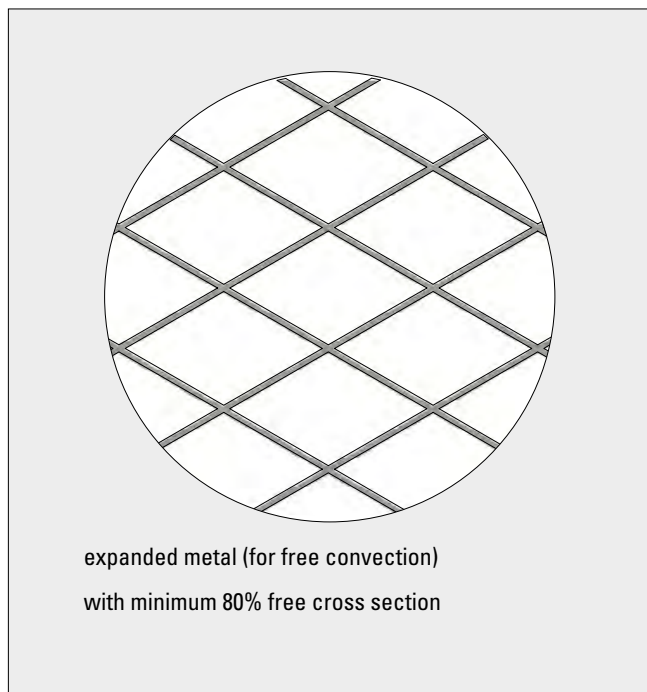

Detail: alternative bearing surface

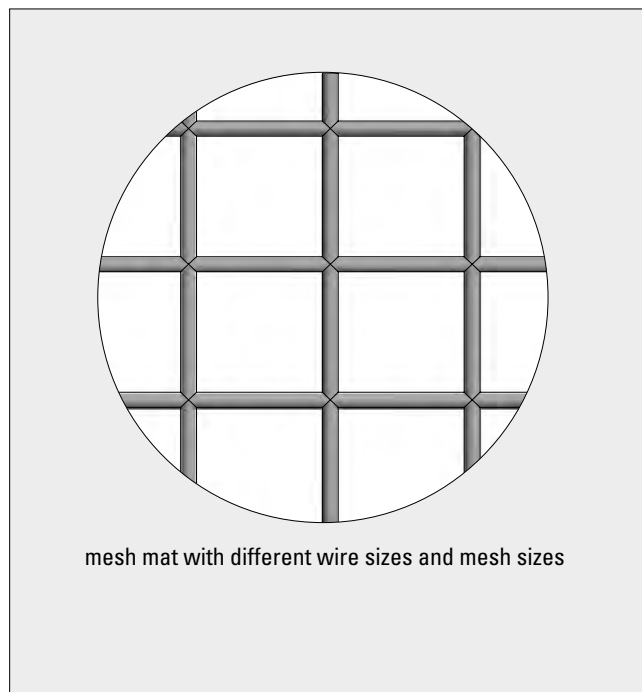



Free convection with direct mounting

Description

The free convection offers a high heating and cooling efficiency due to the unobstructed air circulation. For example, it is suitable for heating individual workplaces in the industrial sector. The aquatherm black system grids are mounted directly on the concrete ceiling. The offered grid sizes allow a variable adaption to the spatial conditions.

Advantages

- *High heating and cooling performance due to free convection*
- *The system can be used variably*
- *Even temperature distribution*
- *Power output without drafts*

Free convection with direct mounting

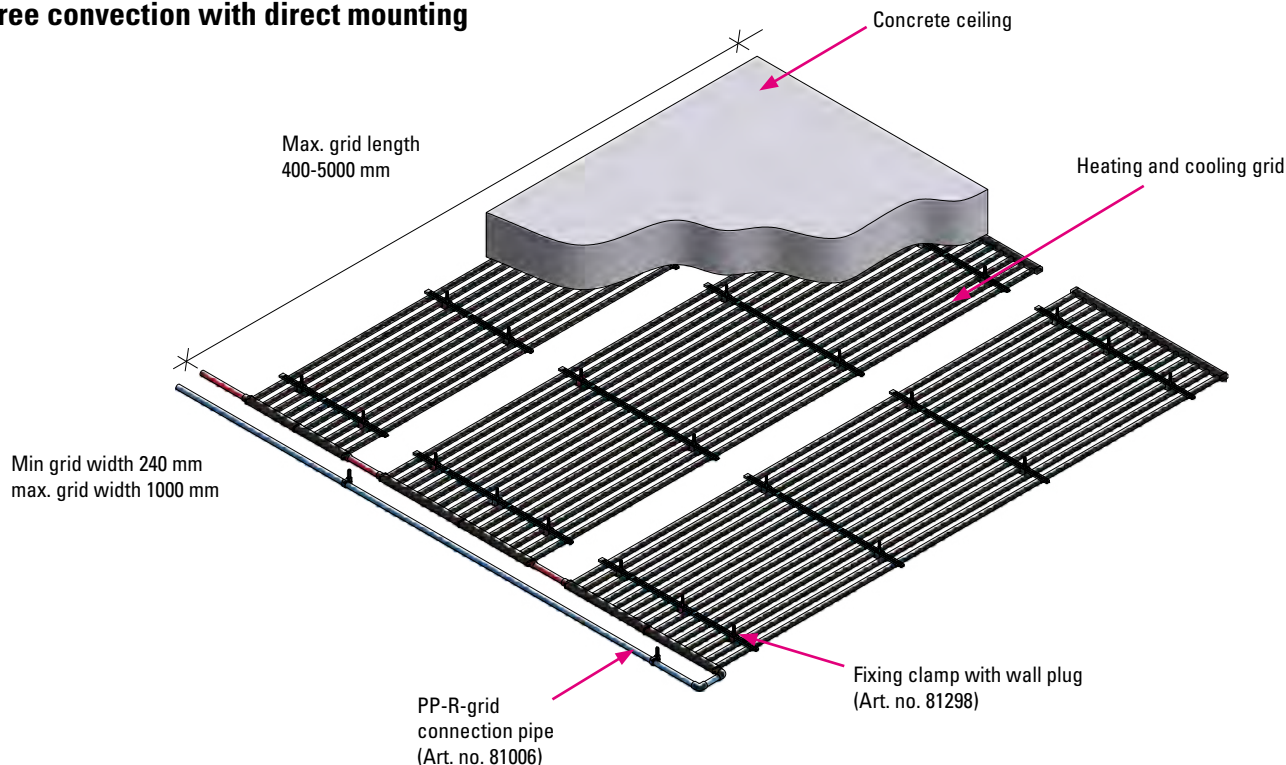

Description

1. Assembly of grids

The grids for installation under the ceiling are supplied with welding sockets (connection type 64) in one-sided design. The assembly is made directly on the ceiling underside. Screws and the fixing clamp with wall plug are required for fastening. Alternatively, the Hilti fastening device can be used.

2. Connection of the grids

The aquatherm black system PP-grid pipe 16 x 2 mm is used to connect the grids with each other or the grid zones at the distributor. With the horizontal arrangement of the aquatherm black system grids, the flow can be connected either left or right. The grids for the installation under the concrete ceiling are provided with welding sockets for the one-sided connection (connection type 64). After installing the grids under the raw ceiling, they are connected with each other according to the laying plan to heating or cooling zones.

Basically, the heating/cooling system must be filled with water and pressed off.

Detail: fixing of connection piping

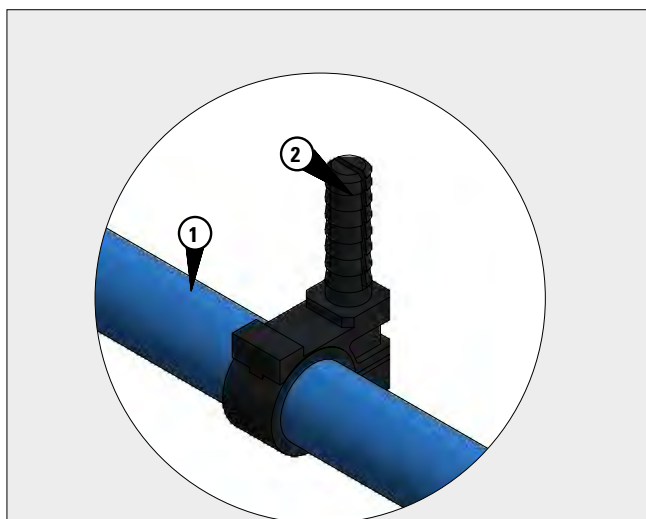

1. PP-R-grid connection pipe (Art. no. 81006)
2. plastic pipe clamp (Art. no.60716)

Detail: Connection piping



1. PP-R-grid connection pipe
2. elbow 90° (Art. no. 81060)
3. f/m elbow 90° (Art. no. 81065)

Free convection with direct mounting

Section: grid fixing ceiling

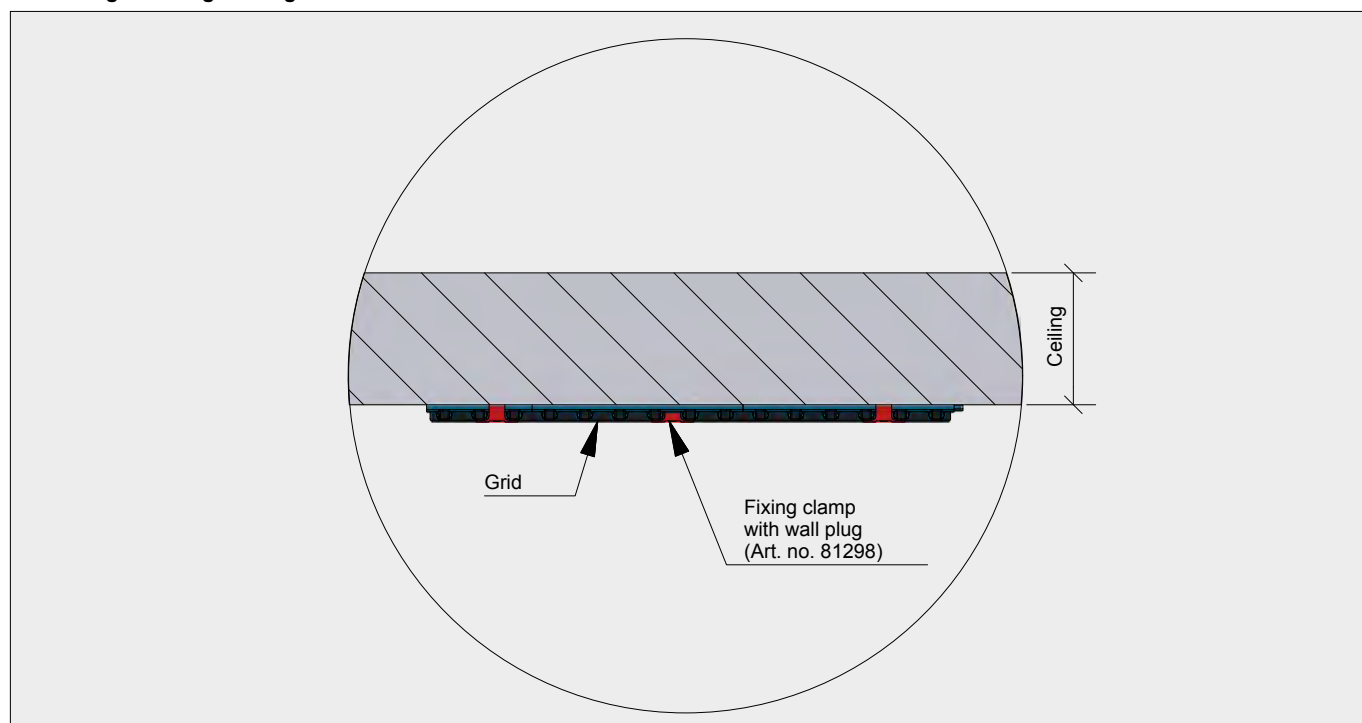

Detail: grid fixing for concrete ceiling

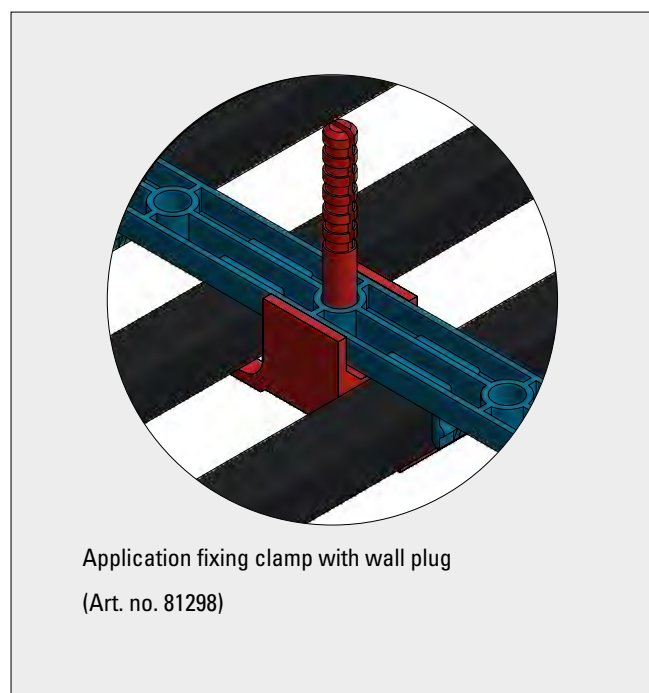

Detail: grid fixing for wooden ceiling

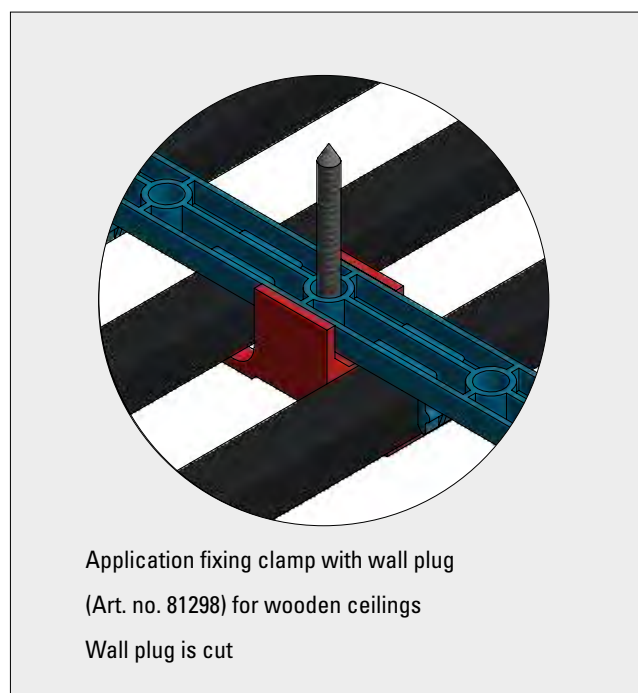

Performance data free convection

Standard **heating performance** according to DIN EN 14037-2

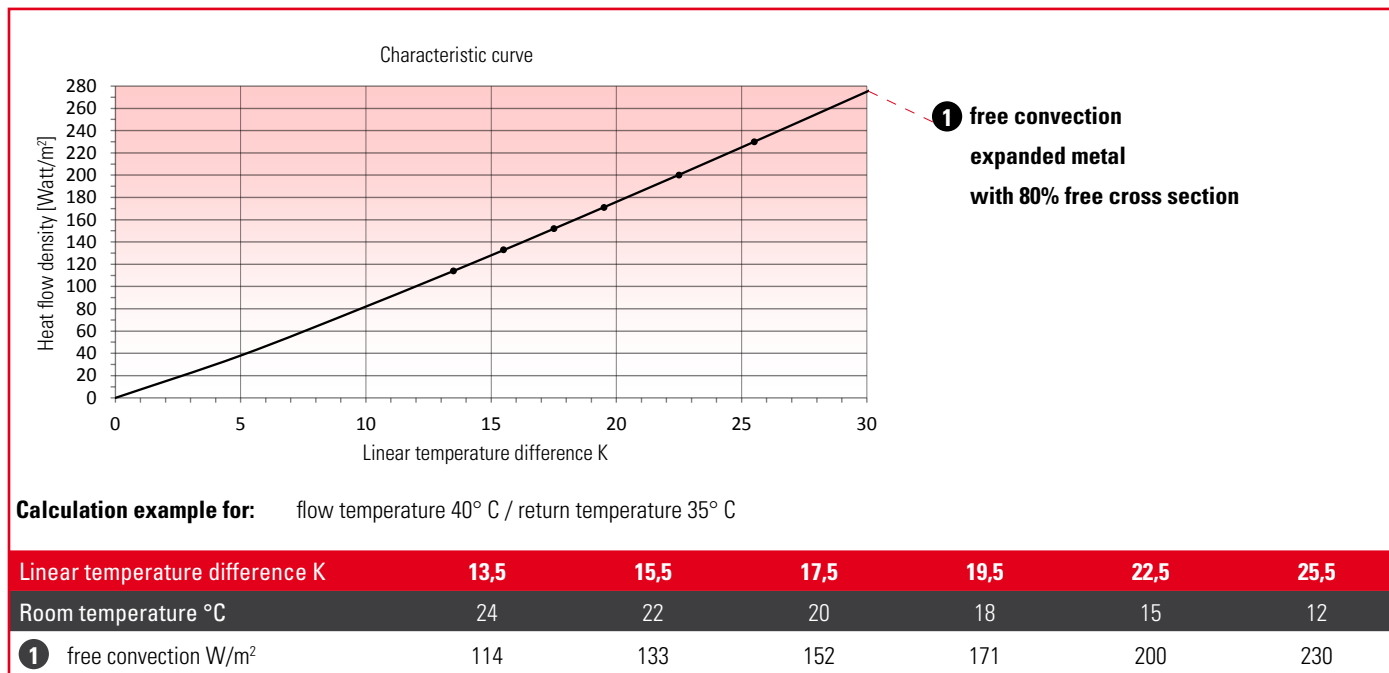

Standard **cooling capacity** according to DIN EN 14240: 2004-04

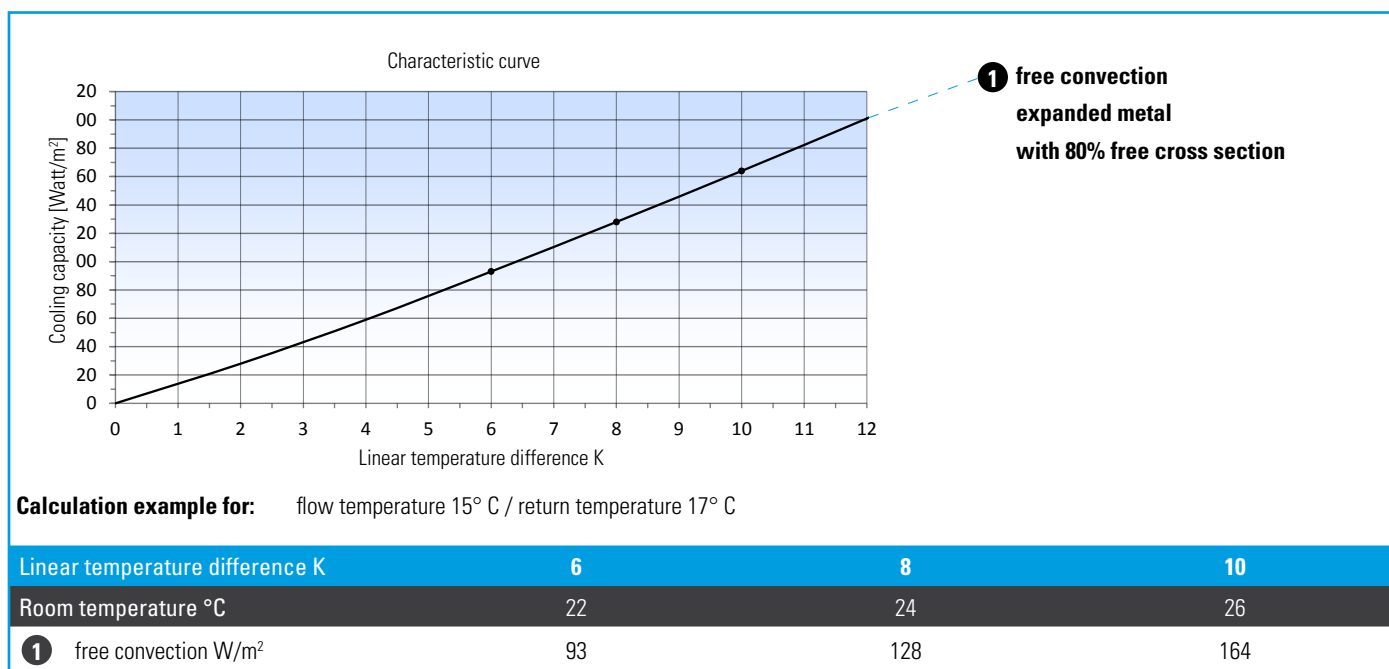



Wall system with metal stud wall and planking with building boards

Description

The aquatherm black system grids are hung between the metal profiles. Then the wall is covered with building boards.

Drywall construction offers individual design options and cost-effective design.

Advantages

- *High heating and cooling performance*
- *Quick and easy installation*
- *Combination with centrally conditioned outside air is possible*
- *Combination of thermally active and passive wall elements is possible*
- *Rapid construction progress thanks to drywall system*

Wall system with metal stud wall and planking with building boards - connection type 64

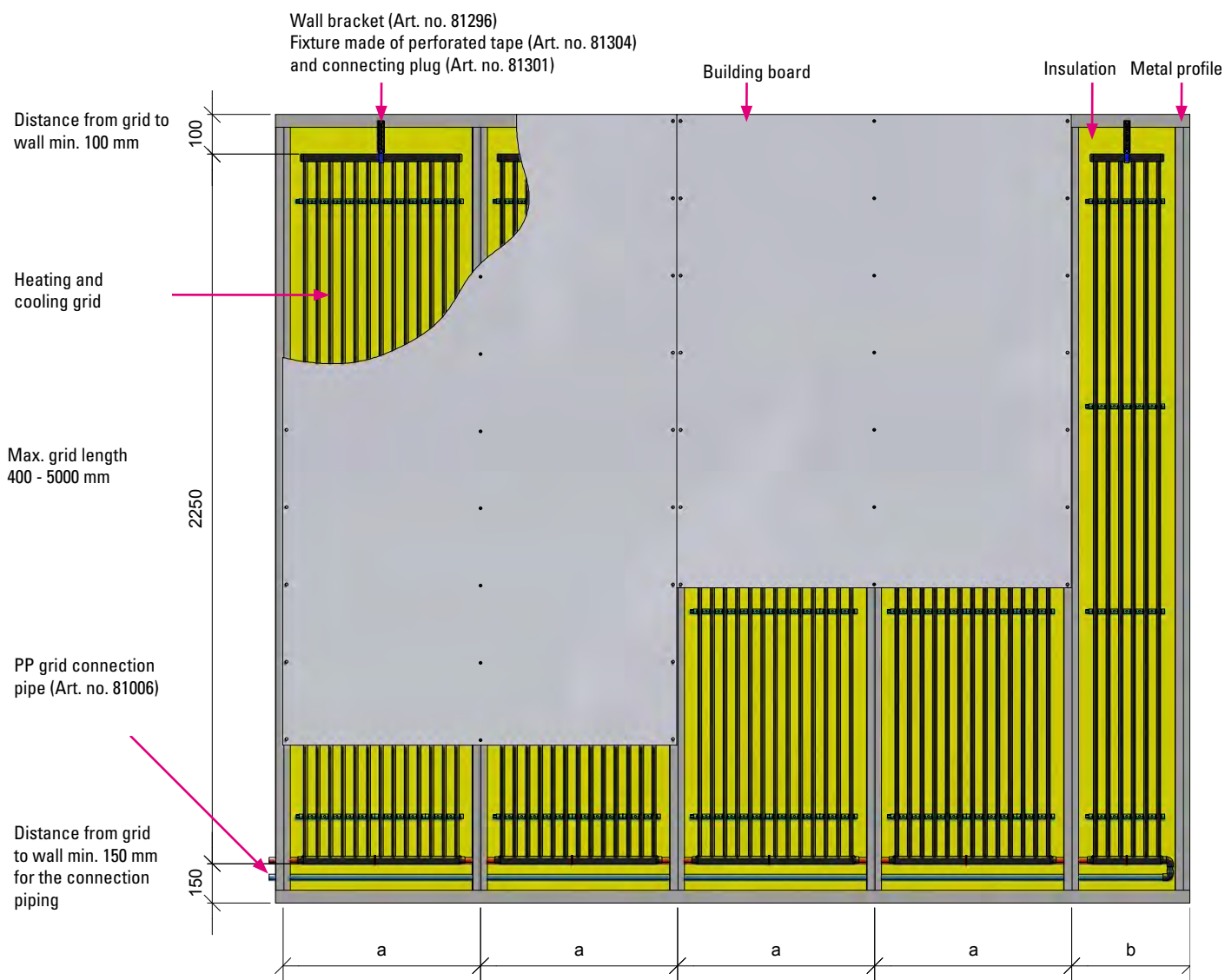

Assembly of grids

1. Assembly of grids

The framework is constructed and aligned according to the manufacturer's instructions in accordance with DIN 18183-1 by the drywall builder. Any required insulation according to fire protection or sound insulation is installed. The axis centre distance of the CW-profiles is usually 625 mm. Depending on the type and design of the metal framework other distances are required. Here, also the respective manufacturer's instructions are to be considered.

2. Assembly of the grids in the metal substructure

The supply of heating/cooling circuits from the distributor or the main supply is led e. g. through the floor/wall into the room in accordance with valid regulations. The custom-made grids are to be hung between the profiles according to the laying plan. For this purpose, the plastic-coated perforated strip is shortened to length and mounted with connecting plugs with the aquatherm black system holders to the upper CW-profile. All necessary components are offered as aquatherm black system accessories.

3. Piping of the grids to heating/cooling circuits

The grids for the installation in wall systems in metal substructure are equipped with welding sockets, one-sided connection (connection type 64). The piping of the grids with each other is made with heating element socket welding with PPR-grid connection pipe 16 mm according to description on page 91-92. The intended H-punching is bent up for the pipe penetrations in the metal stud frame. These should be for all profiles on one level, if possible. Required cut-outs in the metal stud frame are to be created depending on the profile height and type, and always must be according to the manufacturer's instructions. When conducting the grid pipes, the surface

must not be damaged; if necessary, use corrugated pipe, protective pipe or insulating hose to protect the pipes on site.

4. Assembly of building boards

The building boards are screwed to the CW-profiles by the drywall builder according to the manufacturer's instructions. In principle, the grids must be filled with water and pressed off before the planking.

Planning data for wall grids		
a		
Standard width metal profile (mm)	Grid width (mm)	Grid length (mm)
625	520	400 - 5000
500	400	400 - 5000
axis centre distance b min 310 mm, minimum size for smallest grid 240 mm		
Special solutions on request		

Wall system with metal stud wall and planking with building boards - connection type 64

Section: planking with building boards

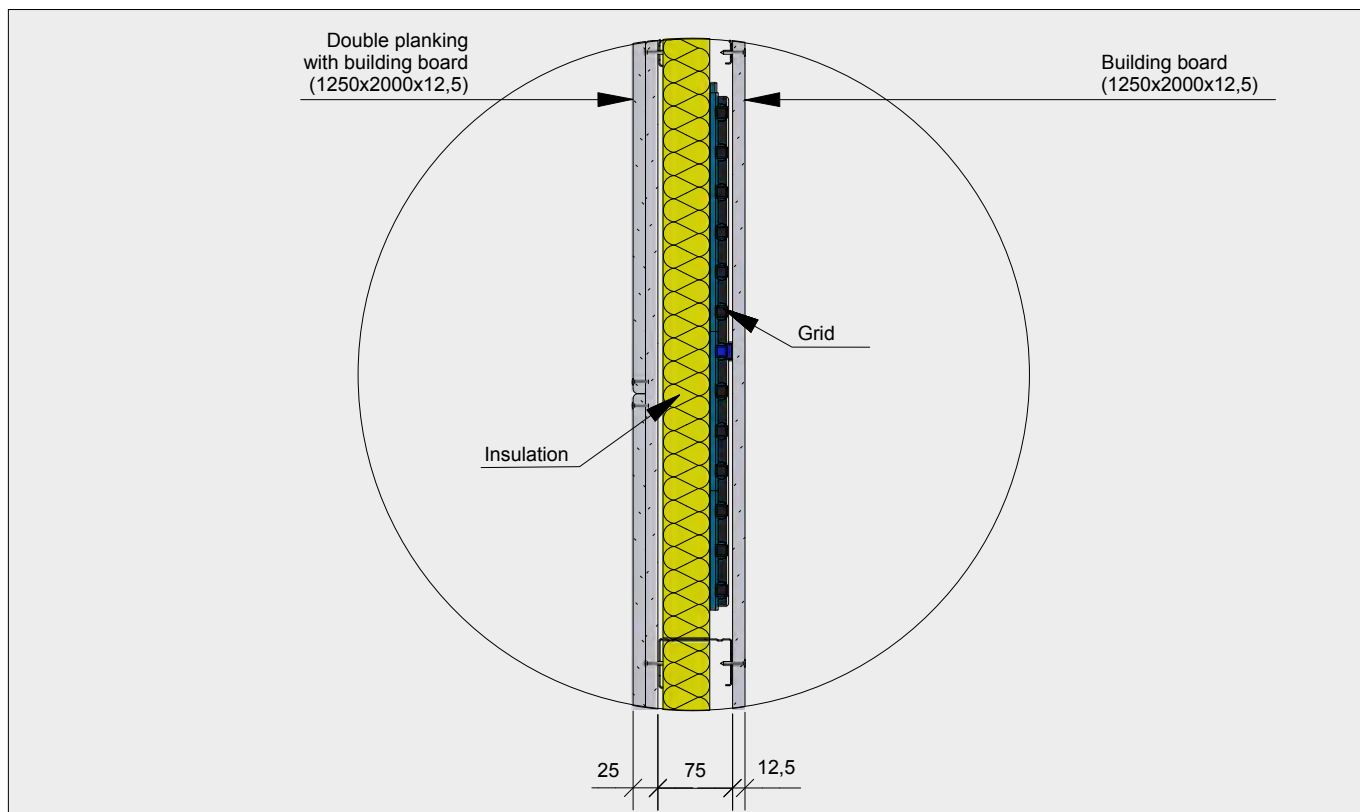

Detail: fixing wall grid

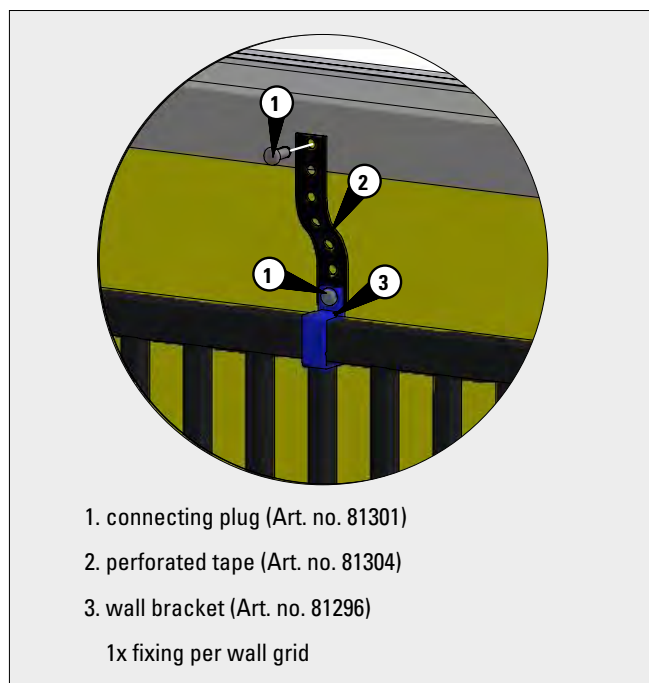

Detail: connection piping

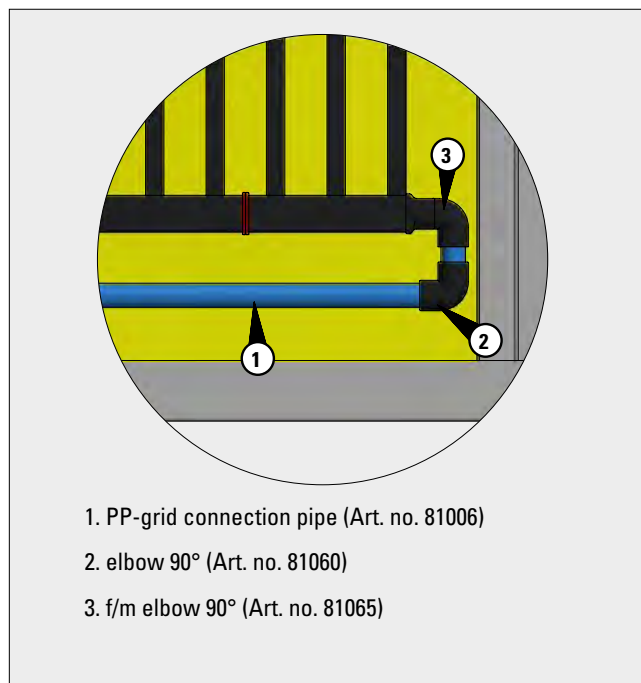

Detail: H-punching in metal profile for connection piping

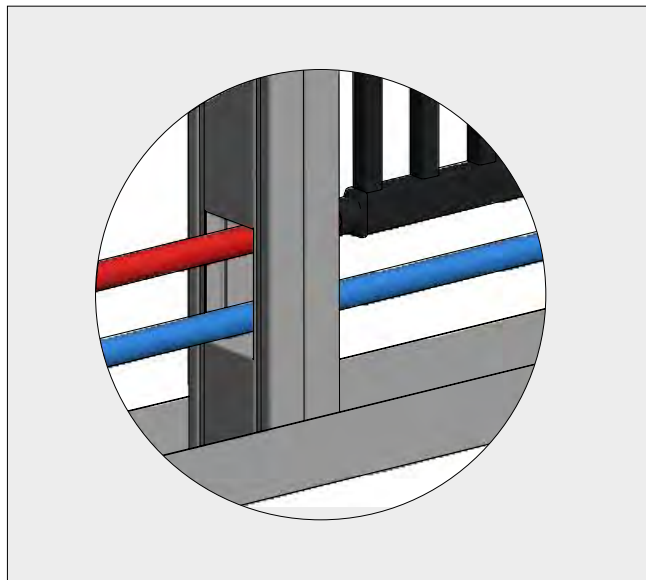
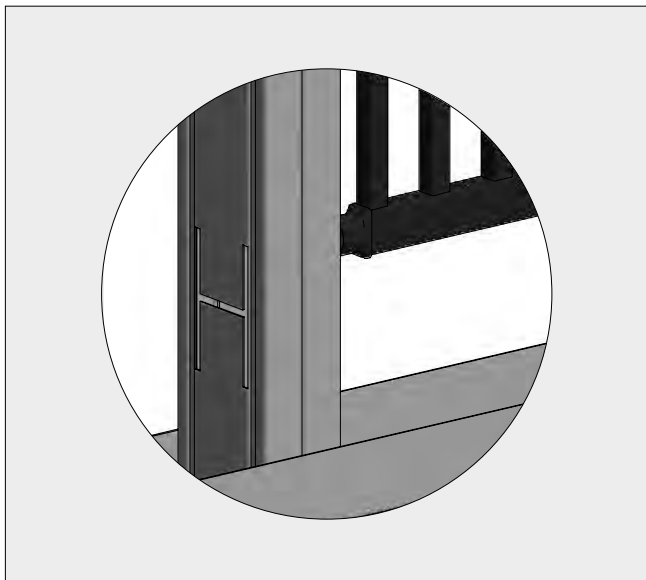

Example

Laying of building boards

Wall system gypsum plasterboard - single-layer vertical planking

Centre distance support profile = 500 & 625 mm

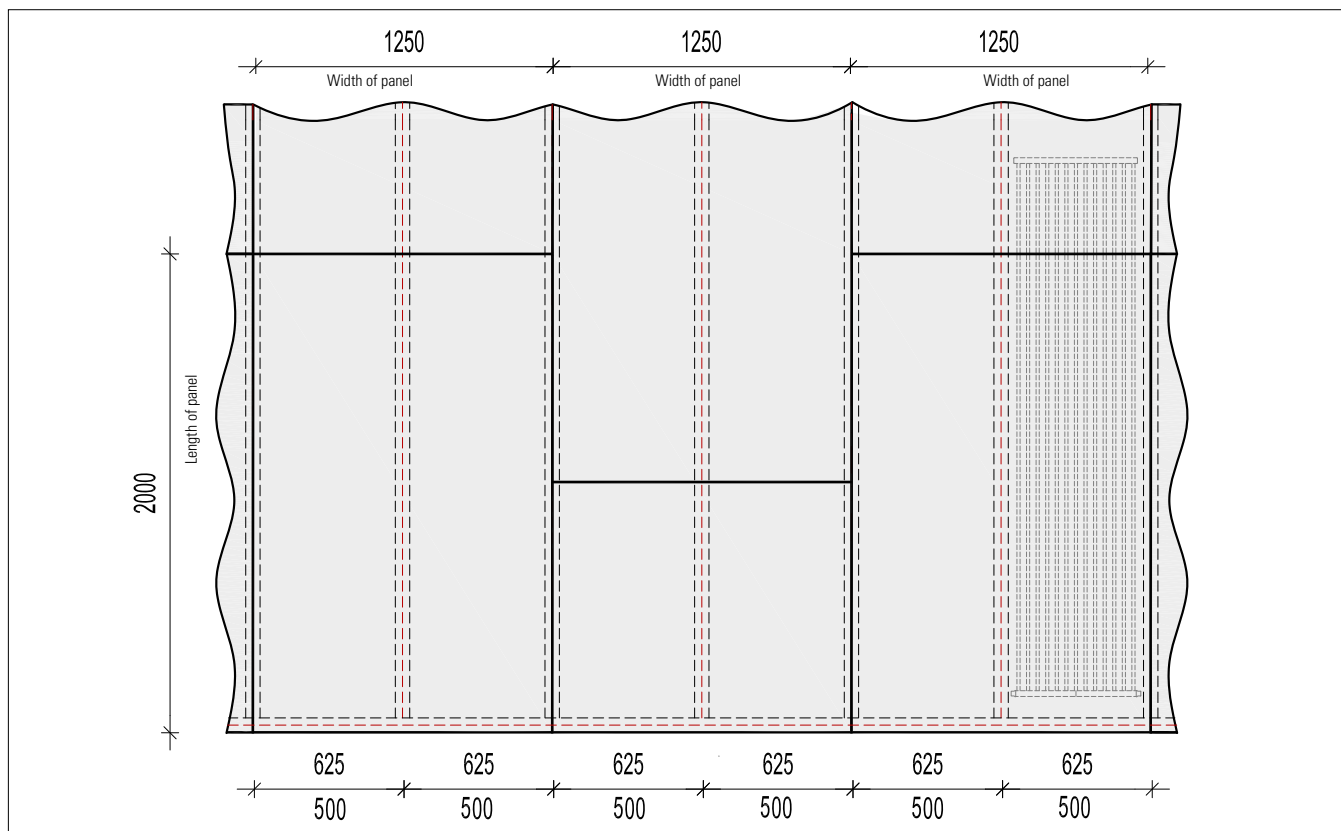



Wall system with wooden stud wall and planking with building boards

Description

The installation of the aquatherm black system grids is made between the slats of the substructure of the wall/roof slope. Then the wall is covered with building boards. Building boards with different thermal conductivities can be used.

Advantages

- *High heating and cooling performance*
- *Even temperature distribution*
- *Quick and easy installation*
- *Combination with centrally conditioned outside air is possible*
- *Power output without drafts*
- *Short heat-up and fast reaction times*
- *Rapid construction progress thanks to drywall system*

Wall system with wooden stud wall and planking with building boards - connection type 64

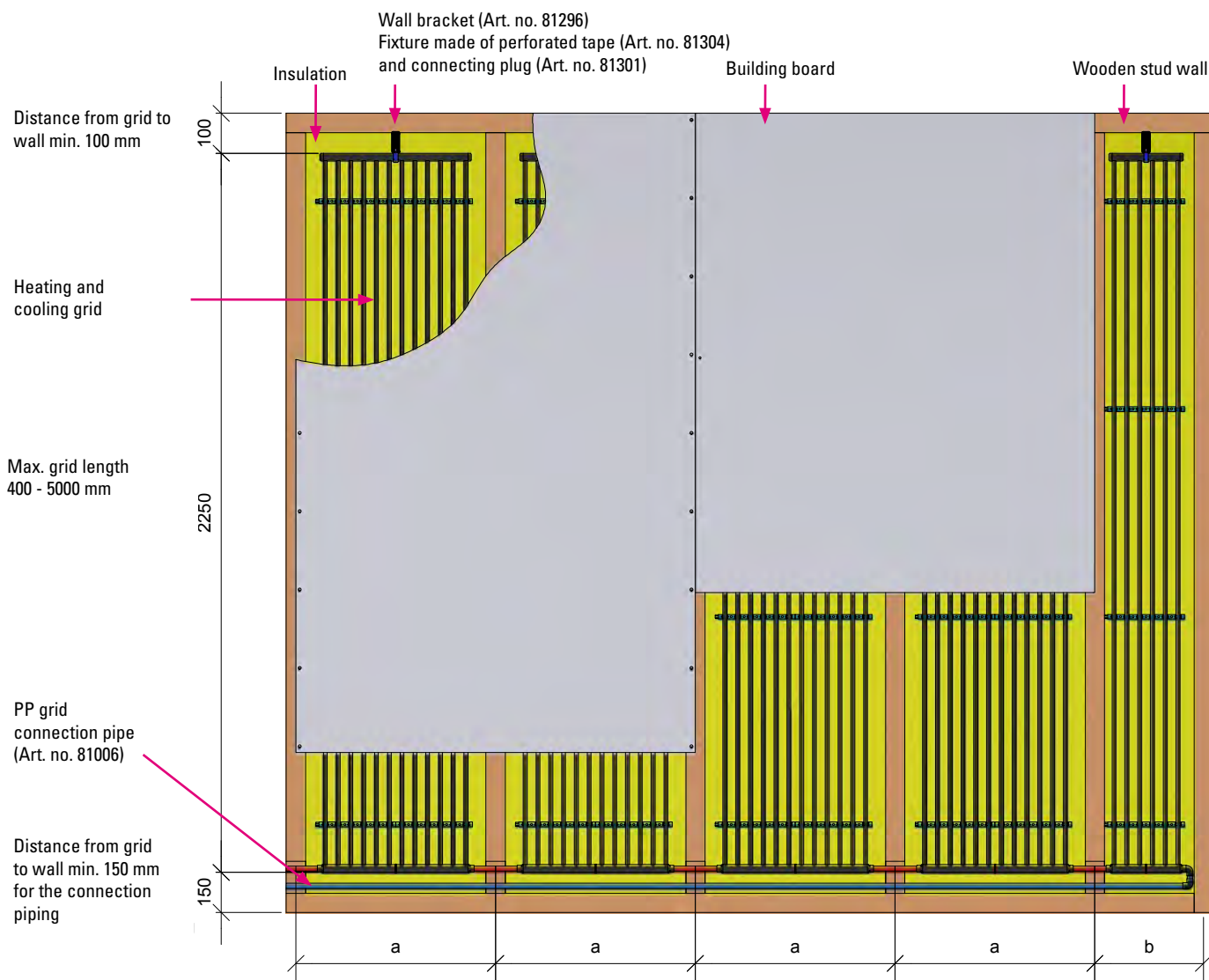

Assembly description

1. Wooden framework

The wooden framework is constructed and aligned according to the manufacturer's instructions by the drywall builder. Any required insulation according to fire protection or sound insulation is installed. The axis centre distance of the CW-profiles is usually 625 mm. Depending on the type and design of the wooden framework other distances are required. Here, also the respective manufacturer's instructions are to be considered.

2. Assembly of the grids in the wooden stud wall

The supply of heating/cooling circuits from the distributor or the main supply is in accordance with valid regulations led e. g. through the floor/wall into the room. The custom-made grids are to be hung between the wooden substructure according to the laying plan. For this purpose, the plastic-coated perforated strip is shortened to length and mounted with connecting plugs with the aquatherm black system holders. The fixing of the perforated strip to the upper circumferential counter battens is done by drywall screws. All necessary components are offered as aquatherm black system accessories.

3. Piping of the grids to heating/cooling circuits

The grids for the installation in wall systems in wooden substructure are equipped with welding sockets, one-sided connection (connection type 64). The piping of the grids with each other is made with heating element socket welding with PPR-grid connection pipe 16 mm according to description on page 91-92. For the pipe penetrations in the wooden substructure,

recesses must be provided in the counter battens. These should be for all wooden studs on one level, if possible.

4. Assembly of building boards

The building boards are screwed to the counter battens by the drywall builder according to the manufacturer's instructions. In principle, the grids must be filled with water and pressed off before the planking.

Planning data for wall grids		
a		
Standard width wooden framework (mm)	Grid width (mm)	Grid length (mm)
625	520	400 - 5000
500	400	400 - 5000
axis centre distance b min 310 mm, minimum size for smallest grid 240 mm		
Special solutions on request		

Wall system with wooden stud wall and planking with building boards - connection type 64

Section: planking with building boards

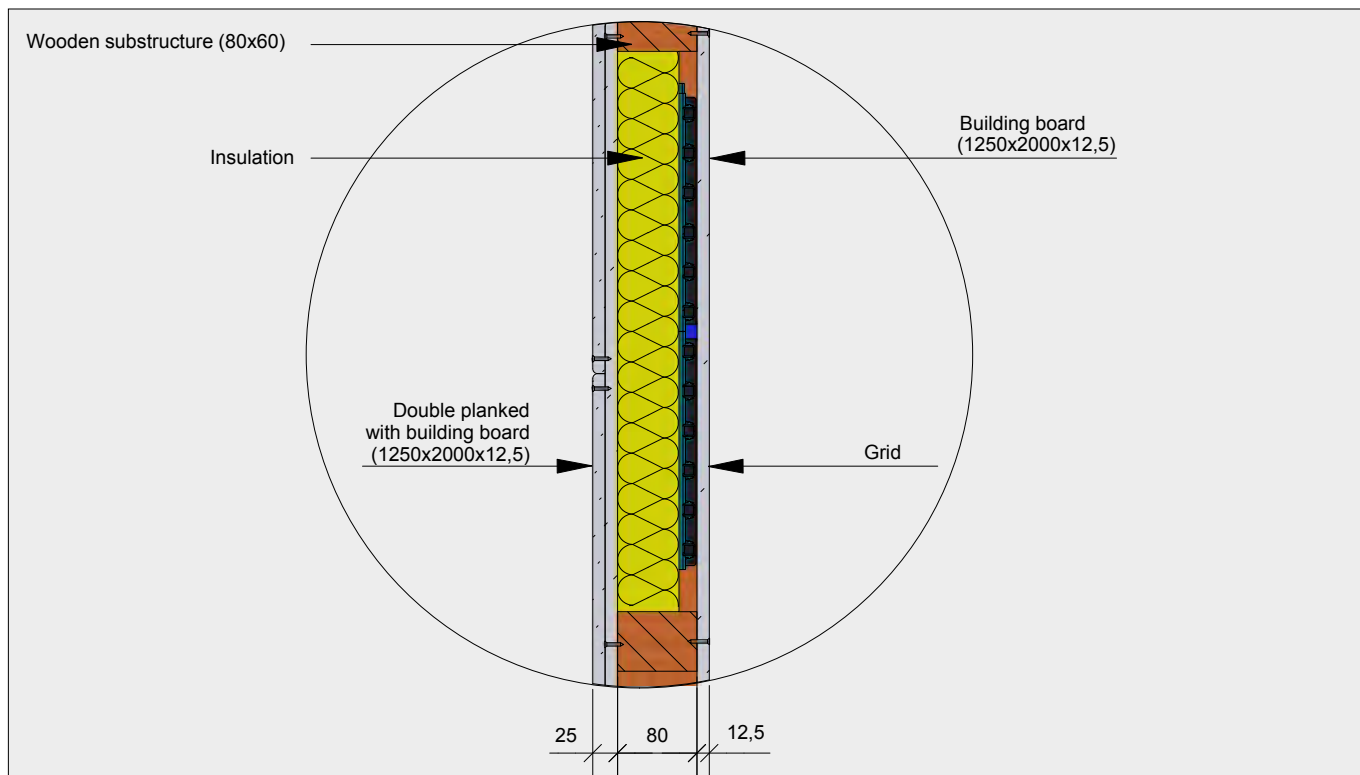

Detail: fixing of wall grid

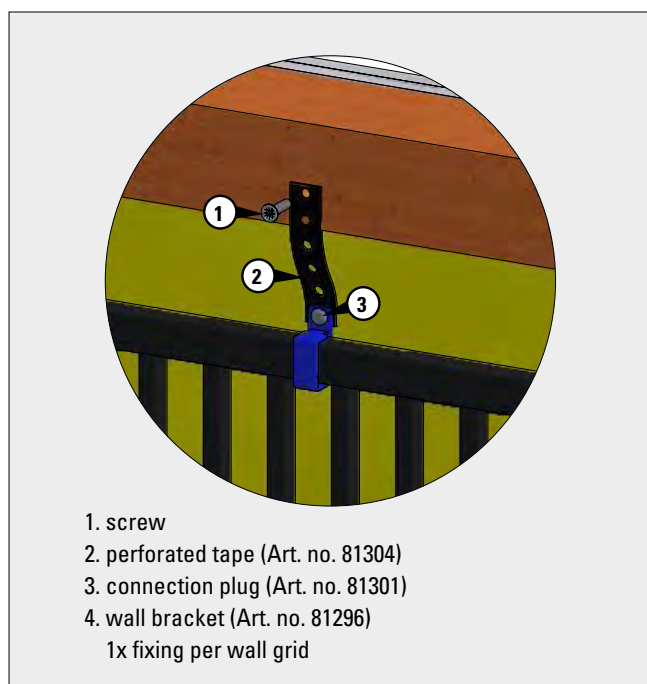

Detail: cut-out for the connection piping

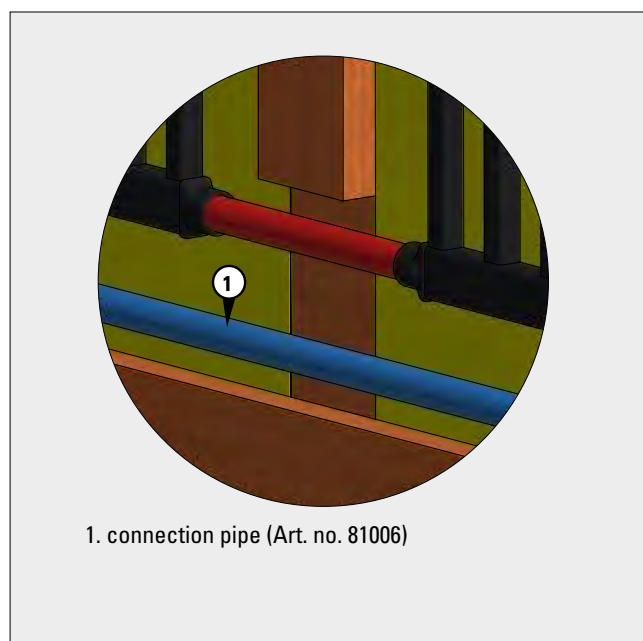



Wall system with wooden substructure and planking with building boards

Description

Before the wall is covered with building boards, the aquatherm black system grids are inserted between the lathe work of the wooden substructure. Building boards made of plasterboard with different thermal conductivities can be used for example. Wall systems with wooden substructure offer architects and planners the greatest possible freedom of design: the wall elements can be individually adapted in shape and dimension to any room geometry.

Advantages

- *High heating and cooling performance due to full surface activation of the wall surfaces*
- *Quick and easy installation*
- *Ideally suited for use with heat pump and condensing boiler technology due to low flow and return temperatures*
- *Installation in combination with various wall integration such as lights, plug sockets, etc.*
- *Power output without drafts*
- *Short heating and fast reaction times*
- *Rapid construction progress thanks to dry construction system*

Wall system with wooden substructure and planking with building boards - connection type 64

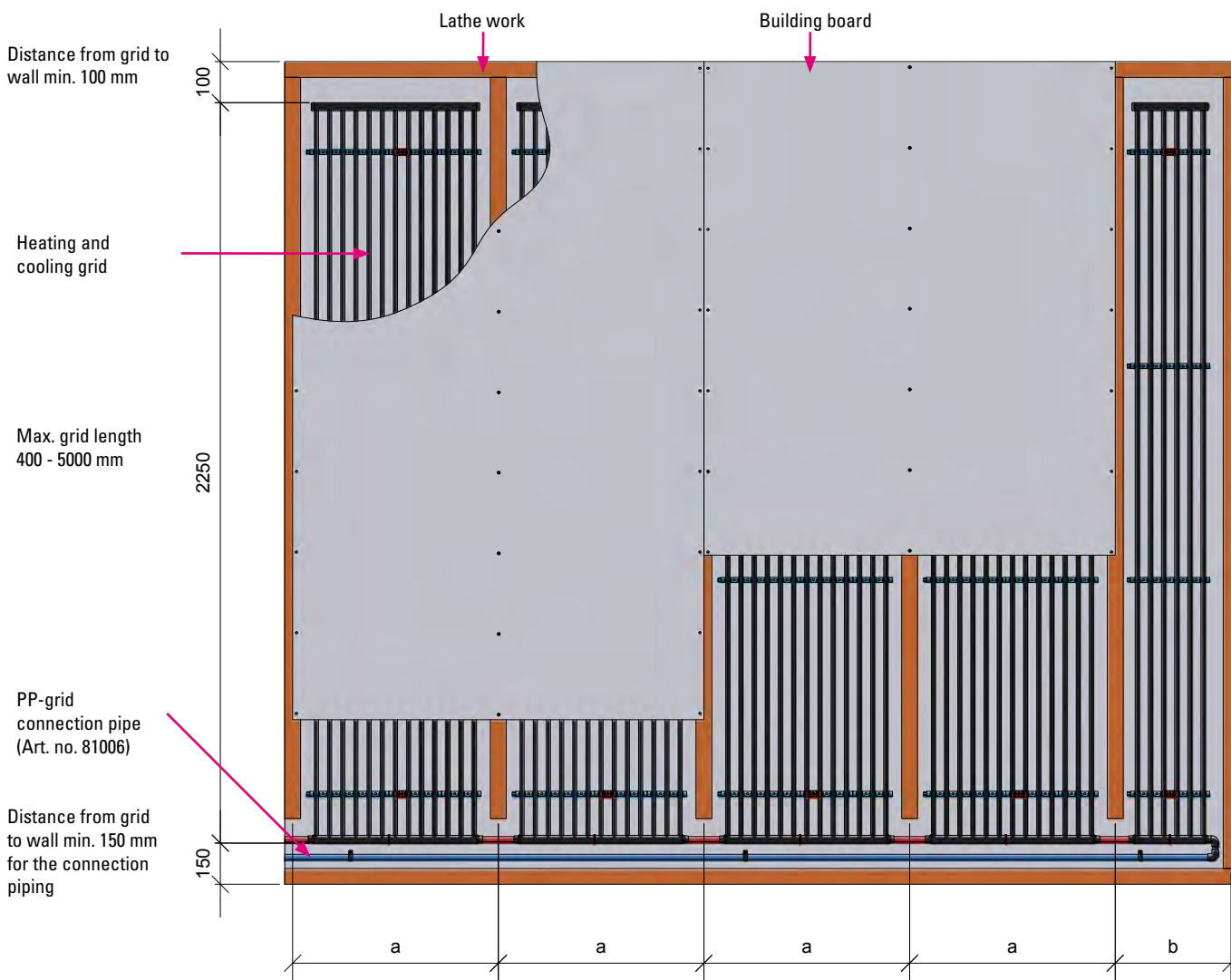

Assembly description

1. Substructure

The lathe work is attached at the concrete wall according to manufacturer's instructions and aligned either vertically or horizontally.

2. Assembly of the grids

The axial distance of the lathe work depends on the building board used and is usually 625 mm. All grids are made-to-measure and the assembly is done between the battens. The grids are bolted directly to the concrete wall. The fixing clamp with wall plug is inserted into the fixing rail and screwed to the concrete wall. Alternatively, it is recommended to fasten with Hilti fastening device (see page 95).

3. Piping of the grid to heating and cooling circuits

The grids for the installation in a wall system with wooden substructure are delivered with welding sockets (connection type 64). After mounting the grids on the wall between the lathe work, they are connected to heating and cooling zones according to installation plan. The aquatherm black system connection pipe is used for this purpose. The attachment of the connection piping is done with fixing clamps (see detail).

4. Assembly of building boards

The grid is mounted between the lathe works. The building boards are now screwed to the slats according to manufacturer's instructions. Care must be taken to ensure that the grids are filled with water during planking and are under pressure.

Planning data for wall grids		
a		
Standard width wooden framework (mm)	Grid width (mm)	Grid length (mm)
625	520	400 - 5000
500	400	400 - 5000
axis centre distance b min 310 mm, minimum size for smallest grid 240 mm		
Special solutions on request		

Wall system with wooden substructure and planking with building boards - connection type 64

Section: grid fixing wall

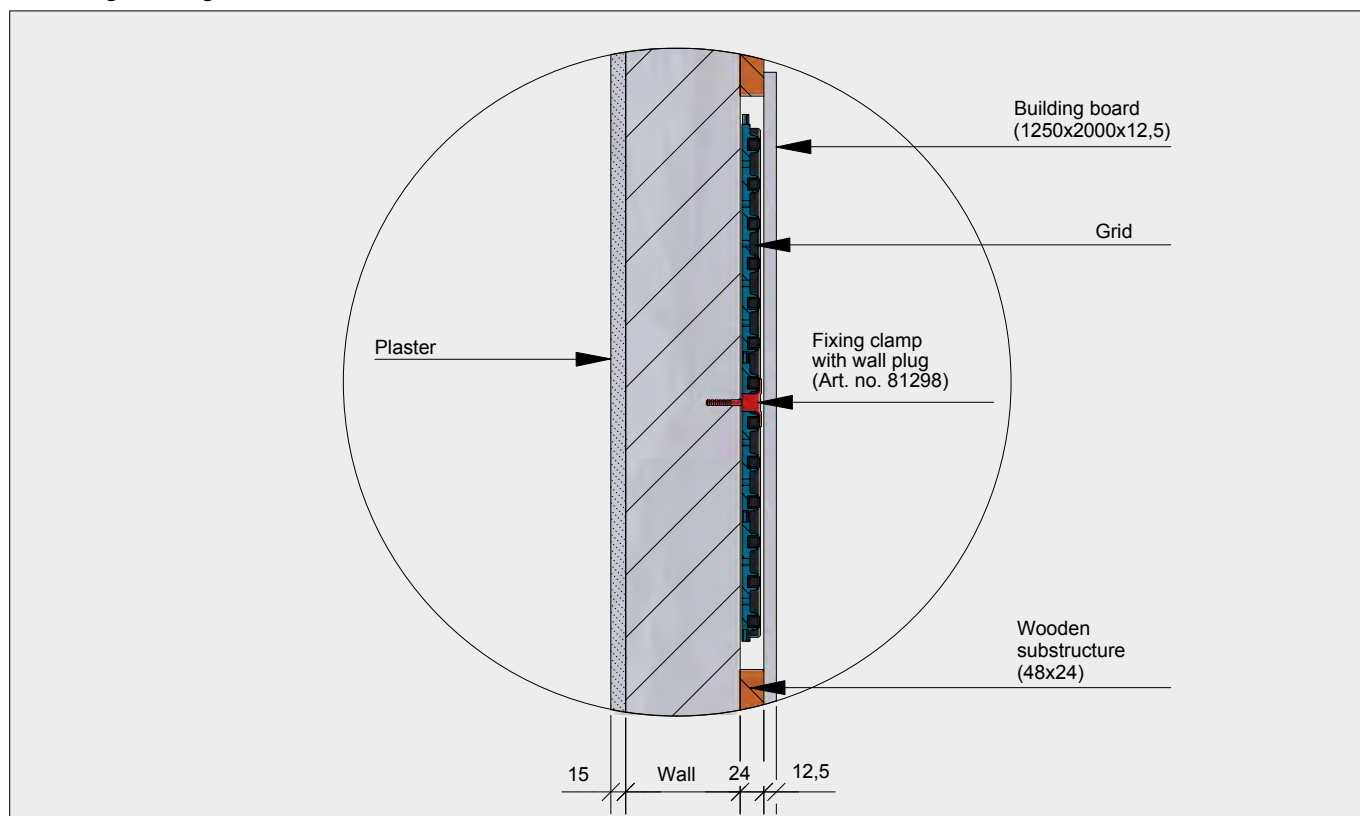

Detail: grid fixing wall

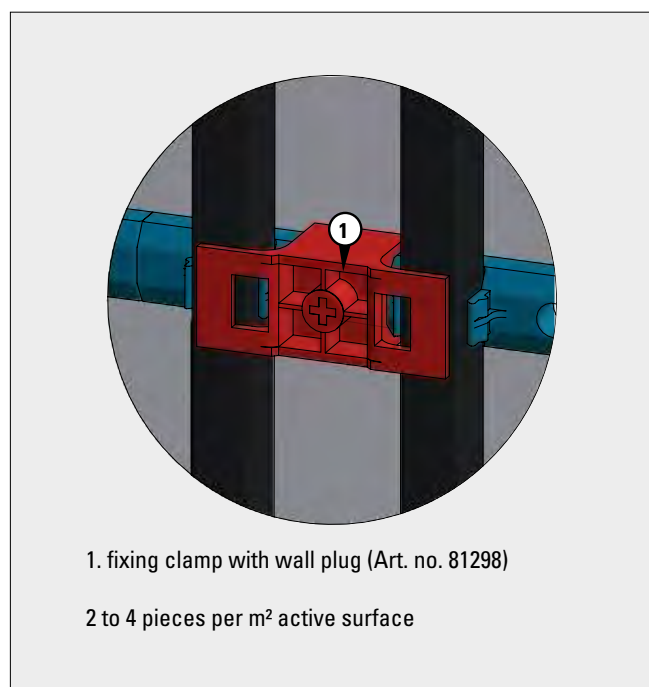

Detail: connection piping

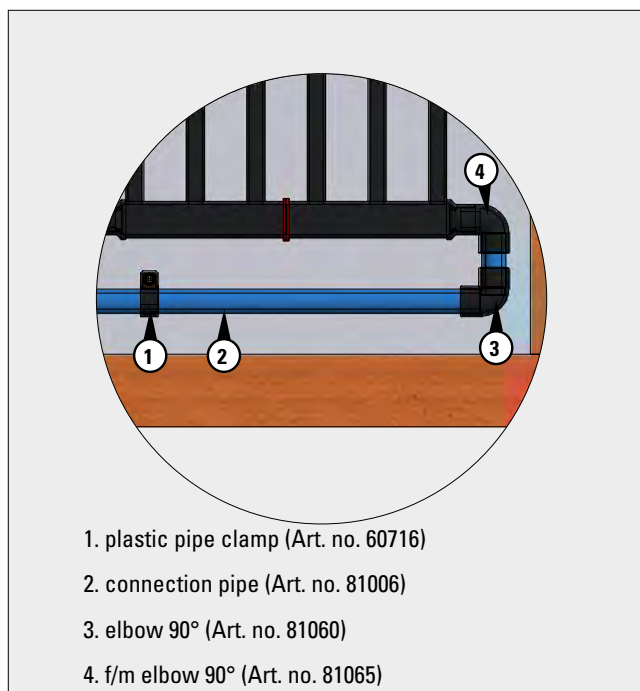

Performance data gypsum plasterboard
Standard heating performance according to DIN EN 14037-2

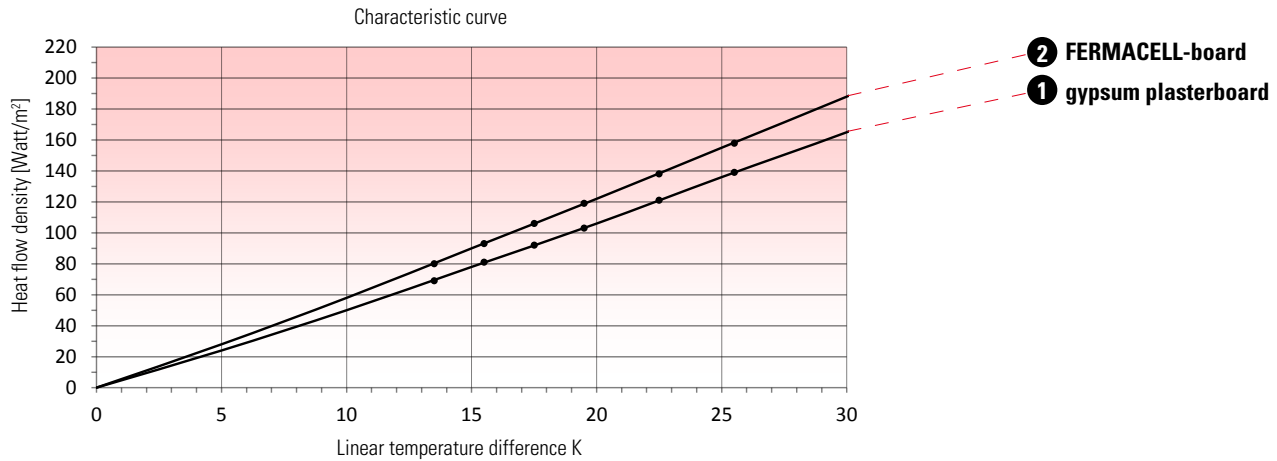

Calculation example for: flow temperature 40° C / return temperature 35° C

Linear temperature difference K	13,5	15,5	17,5	19,5	22,5	25,5
Room temperature °C	24	22	20	18	15	12
① gypsum plasterboard 12,5 mm W/m ²	69	81	92	103	121	139
② FERMACELL-board 12,5 mm W/m ²	80	93	106	119	138	158

Standard cooling capacity according to DIN EN 14240: 2004-04

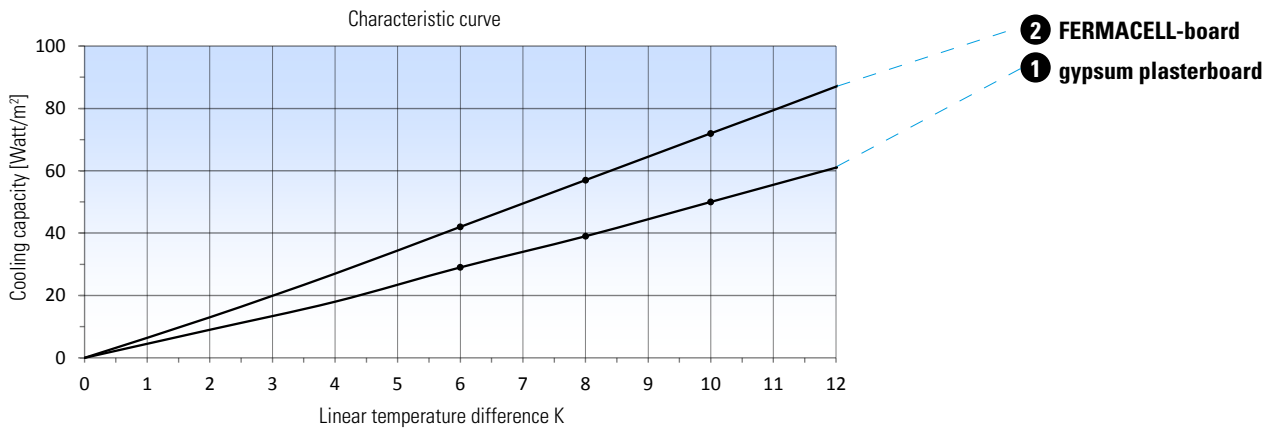

Calculation example for: flow temperature 15° C / return temperature 17° C

Linear temperature difference K	6	8	10
Room temperature °C	22	24	26
① gypsum plasterboard 12,5 mm W/m ²	29	39	50
② FERMACELL-board 12,5 mm W/m ²	42	57	72



Wall system plastered

Description

The aquatherm black system grids for heating and cooling are integrated directly into the plaster layer on the wall. The grids and the connection piping are fixed on the wall. Subsequently, the plastering takes place in compliance with the general plaster guidelines. All commercial plasters of gypsum, lime, cement and clay are suitable.

Advantages

- *High heating and cooling performance due to full surface activation of the wall surfaces*
- *Noiseless and draft-free heating and cooling function*
- *Short heat-up and fast reaction times*
- *Pleasant room climate*
- *Installation is possible on nearly all wall surfaces*

Description

1. Substrate requirements

The substrate must be dry and flat to accommodate the plaster according to the manufacturer's instructions. Plasters can usually be applied to all plaster substrates. Regarding the adhesion, a distinction must be made between easy-to plaster and difficult substrates. The choice of plaster, the working method and the pre-treatment of the substrate must be adjusted to the local conditions. The test of the substrate by the contractor (plasterer) is compulsory according to VOB part C, DIN 18350 resp. VOB, part B, DIN 1961. The tolerances of the altitude and inclination of the supporting ground must comply with DIN 18202. Plasterworks should only be performed by specialist companies with appropriate evidence. Due to the processing (one-ply or two-ply

plaster), only the layer thickness of the plaster used changes when heating grids are installed.

The specialist company checks the substrate by:

- optical check
- smear test (hand check)
- scratch test (spatula, trowel, etc.)
- wetting test (check, if there are rests of release agent)
- CM-device (measurement of moisture content)
- temperature measurement (at low temperatures)

After the substrate check, the material for pretreatment is selected.

Suitable methods are:

- primer coat
- burn-up barrier
- primer
- metallic plaster base (for critical substrates)

Basically, the guidelines and instructions of the plaster manufacturer must be observed.

Wall system plastered – connection type 64

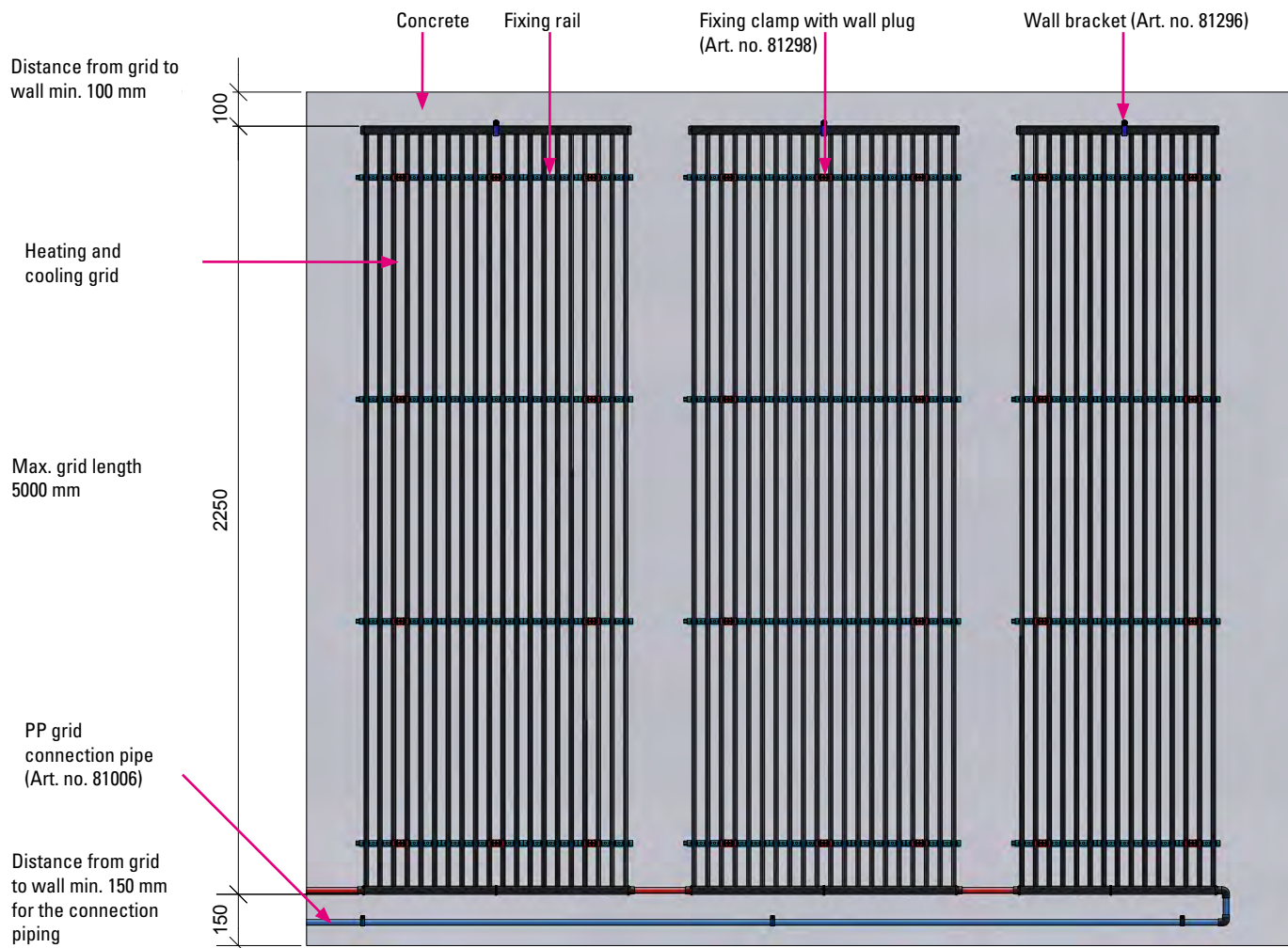

Assembly description

1. Assembly of the grids

aquatherm black system grids or grid pairs are fixed to the raw wall with fixing clamps with wall plug according to the installation plans. Here, the fixing clamp is dowelled through the fixing rail, which is in intervals at the grid, into the raw ceiling. For connecting the grids with each other or the grid zones to the distributor, the aquatherm black system PP grid pipe 16 x 2 mm with the plastic fixing clamps is used.

2. Connection of the grids

If the aquatherm black system grids are horizontally arranged, the flow can be connected either on the left or on the right. The grids for installation in a wall system with plaster have a one-sided connection with welding sockets. After mounting the grids on the raw wall, they are connected to each other or to heating or cooling zones according to the installation plan.

3. Plastering the wall

Now, the wall can be plastered with 10 mm plaster coverage from the top edge of the heating pipe according to the manufacturer's instructions. Care must be taken to ensure that the grids are filled with water during planking and are under pressure.

Finding aquatherm grids in ceiling, wall and floor

For retrofitting of pictures, mirrors or similar aquatherm offers a thermal foil, with which the aquatherm black system grids, installed in the ceiling, wall and floor and thus no longer visible, can be made visible again. As an alternative to the thermographic camera, the coated film indicates the temperature differences by discoloration.

1. The surface must be cool. In this state, the film is placed on the surface.
2. The heating process can be started.
3. In the heating phase, the heating pipes of the grids become slowly visible through colour changes. The duration depends on the grid coverage.

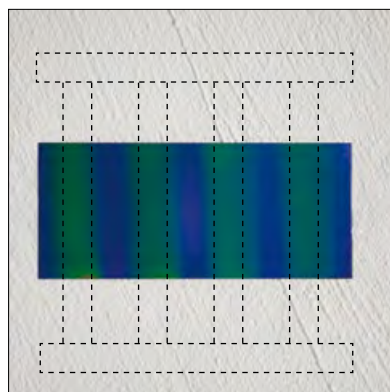

Wall system plastered – connection type 64

Section: grid fixing wall

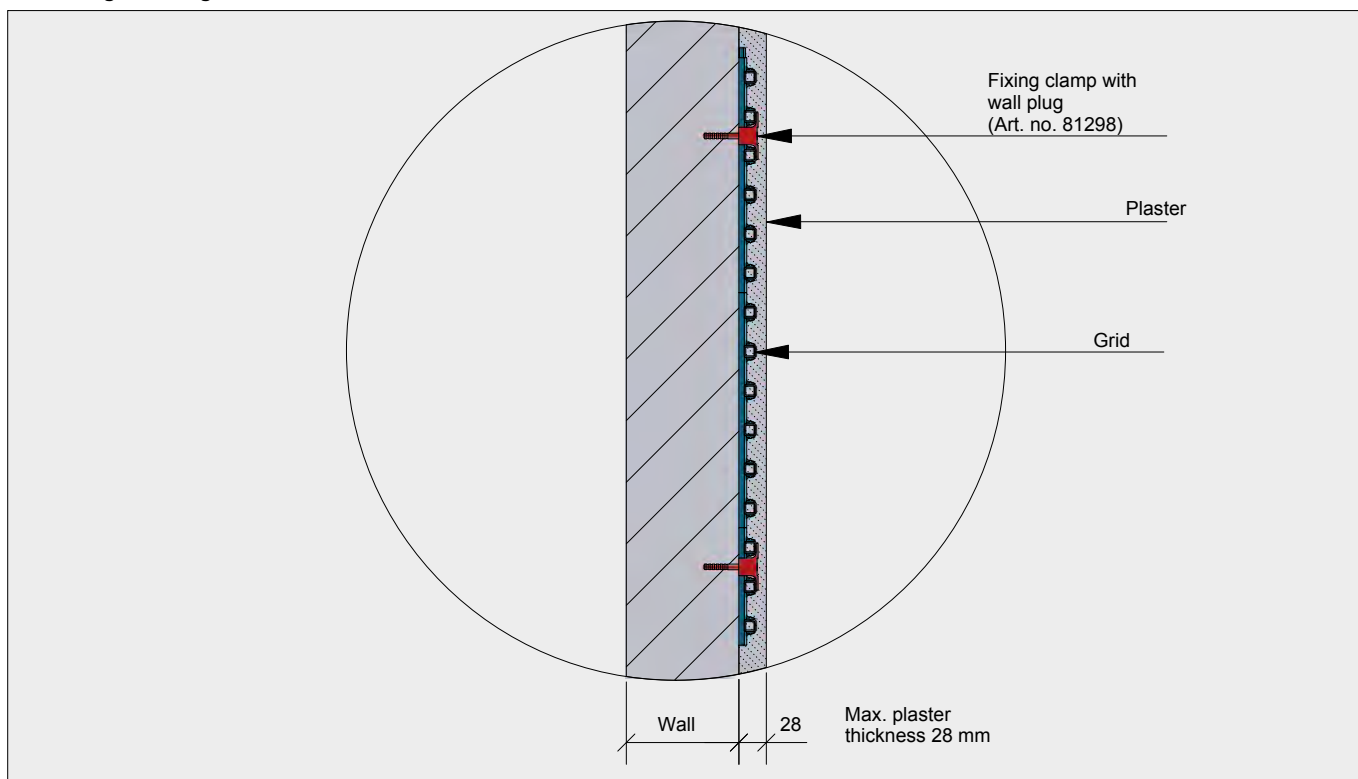

Detail: grid fixing wall

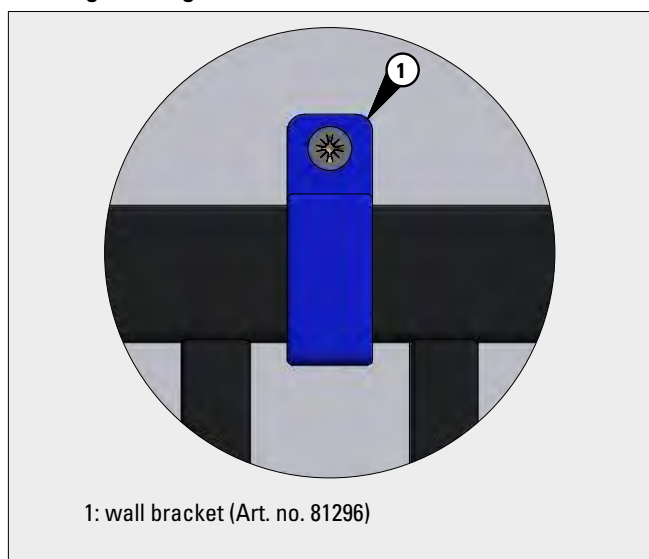

Detail: grid fixing wall

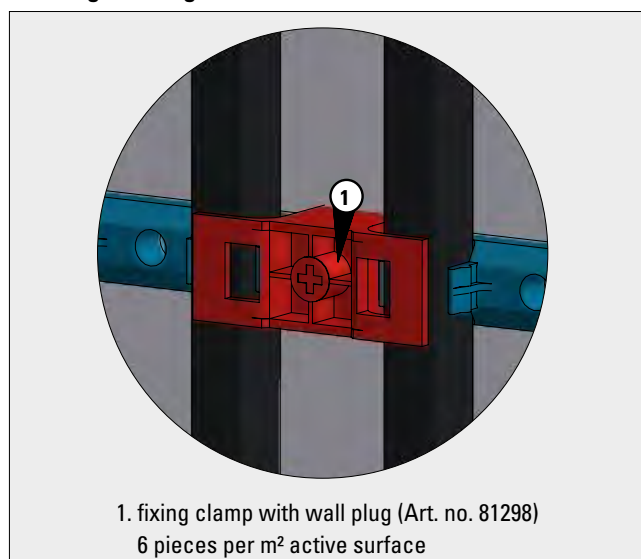

Detail: connection piping

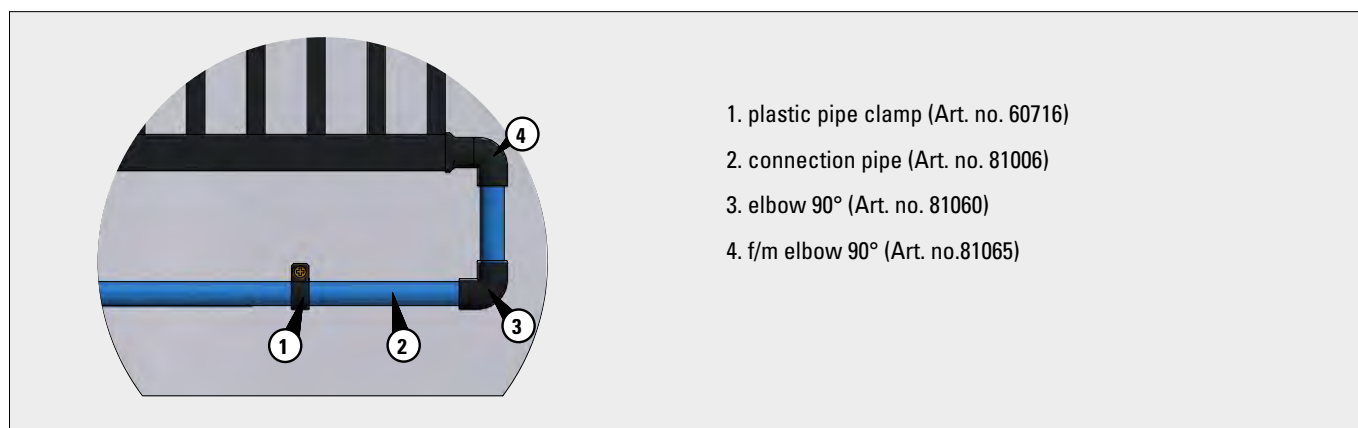

Performance data wall system plastered

Standard **heating performance** according to DIN EN 14037-2

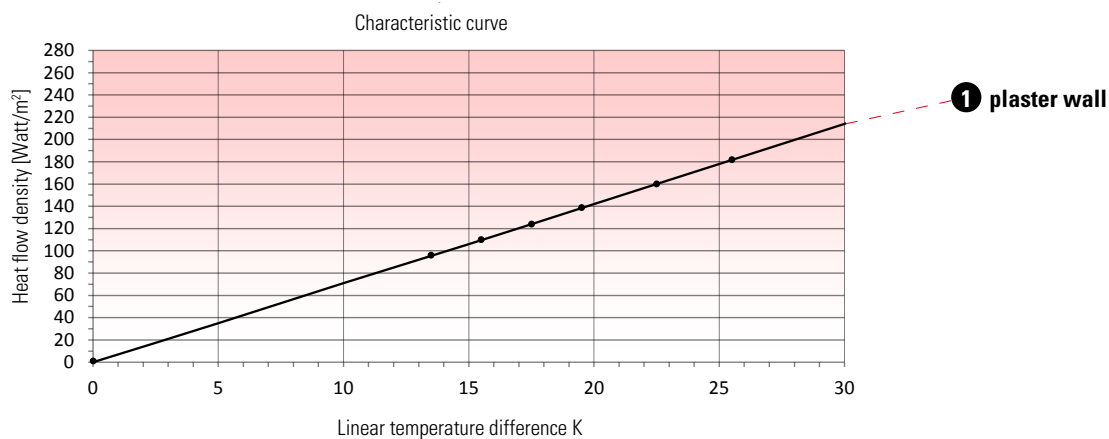

Calculation example for: flow temperature 40° C / return temperature 35° C

Linear temperature difference K	13,5	15,5	17,5	19,5	22,5	25,5
Room temperature °C	24	22	20	18	15	12
1 plaster wall W/m ²	90	105	119	134	156	178

Standard **cooling capacity** according to DIN EN 14240: 2004-04

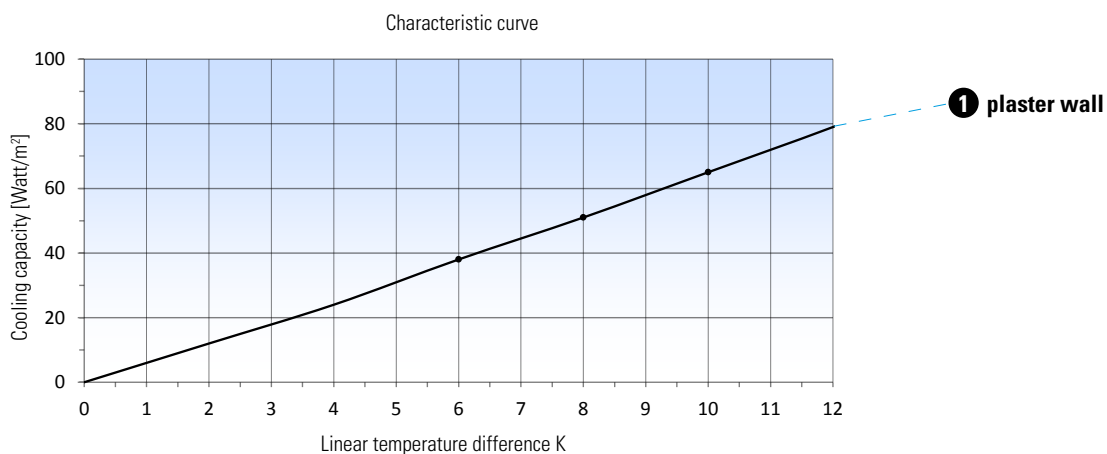

Calculation example for: flow temperature 15° C / return temperature 17° C

Linear temperature difference K	6	8	10
Room temperature °C	22	24	26
1 plaster wall W/m ²	38	51	65

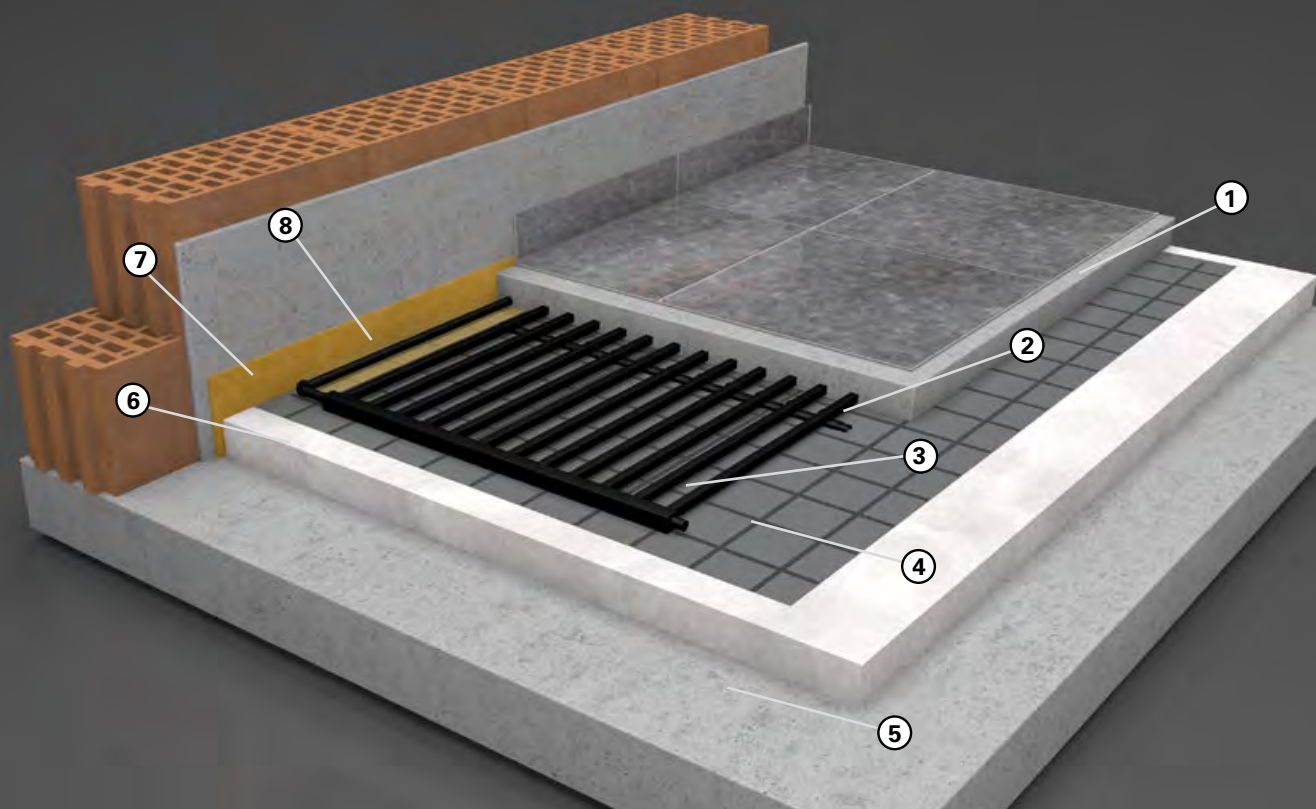

- | | | |
|---------------|------------------------|---------------------------------|
| ① screed | ④ insulation covering | ⑦ edge insulation strip |
| ② fixing rail | ⑤ raw concrete ceiling | ⑧ connection pipe /PP-grid pipe |
| ③ grid | ⑥ insulation | |

Underfloor heating

Description

The aquatherm black system grids are also suitable for underfloor heating in the screed. The grids are connected and lined on one side. To avoid floating when pouring the screed, the grids must be fixed on the insulation. All types of screed approved for underfloor heating can be used. The coverage depends on the type of screed.

Examples of application



1. aquatherm wall and underfloor heating combined in one circuit.



2. aquatherm black system as surface heating system on insulation at site.



Technical grid

Description

In heating-cooling ceilings lighting fixtures, sprinklers, loudspeakers, air outlets, etc. are installed. A high degree of occupancy in these areas can be achieved with technical grids. The heating-cooling grids are adapted to the installation body. Individual grid bars are removed at the factory. This is feasible for all connection types. With technical grids, e.g. in case of metal panel ceiling, almost all types of lighting can be realized without large reduction of heating-cooling surfaces. In dry systems with planking of building boards, recessed ceiling lights are often used. Technical grids are also a perfect choice for this application to achieve a high degree of occupancy.

In wall systems, e.g. thermostatic bathtubs in the shower area, electrical outlets and loud speakers can be applied. Nevertheless, the required occupancy area is achieved.

For the production of the technical grids the dimensions of the grid as well as of the recess are required.





Application in the shower

Advantages

- Comfortable heat in the shower area
- Easy installation
- Individually adaptable to shower size and shower fitting
- Applicable in combination with existing radiator system via return temperature limiter
- Suitable for connection to all common underfloor heating systems
- Residual heat requirement can be covered
- Installation in new and old buildings is possible

Application in the mirror

Advantages

- Non-fogging mirror
- Easy installation
- Individually adaptable to any mirror size
- Suitable for combination with existing radiator system via return temperature limiter
- Connectable to all common underfloor heating systems
- Optimal supplement to the wall heating in the shower



CHAPTER CONNECTION TECHNOLOGY

Connection technology

Various connection variations are available for connecting aquatherm black system to the piping

Corrugated connection pipe with different connection types

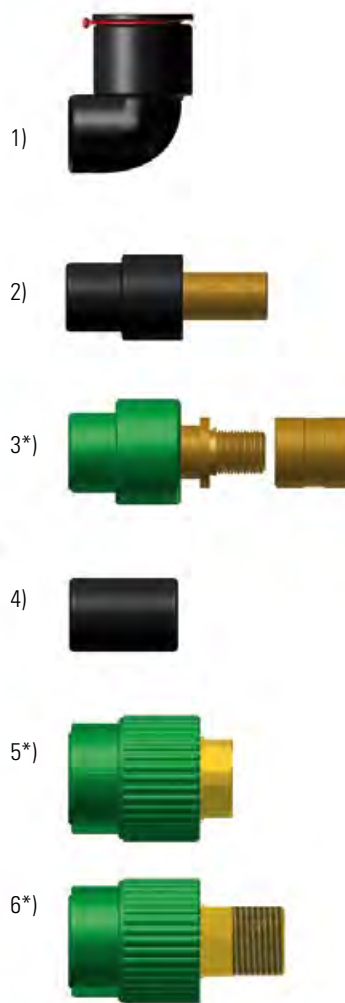

- 1) push-fit connection with safty clip
- 2) transition adapter with press connection 15 mm
- 3) sliding sleeve connection
- 4) welding connection
- 5) transition with female thread
- 6) transition with male thread

* (accessories from the aquatherm green pipe program)

Connection technology part 1: Fusion

aquatherm black system grids with connection type 64 are reconnected to each other by heating element socket welding.

By heating the connection parts, the plastic merges into a cohesive and permanent connection.

With the comprehensive range of aquatherm green pipe fittings, both individual connections and complete large systems can be built including distribution technology.

Transition connectors to the proven aquatherm grey pipe sliding sleeve technology as well as to the aquatherm orange system and a 15 mm press connection complete the system.

Processing advice

Different wall thicknesses of aquatherm green pipe fittings and aquatherm black system components require slightly different heating-up times. Care should be taken to ensure that the aquatherm green pipe fittings are pushed first onto the welding tool due to the thicker wall thickness and only then the aquatherm black system PP-grid pipe is heated up.

Fusion of aquatherm black system

aquatherm black system grids with connection type 64 can be connected with each other to grid zones.



1. Welding device and tool (16 mm) mounted; temperature control performed.

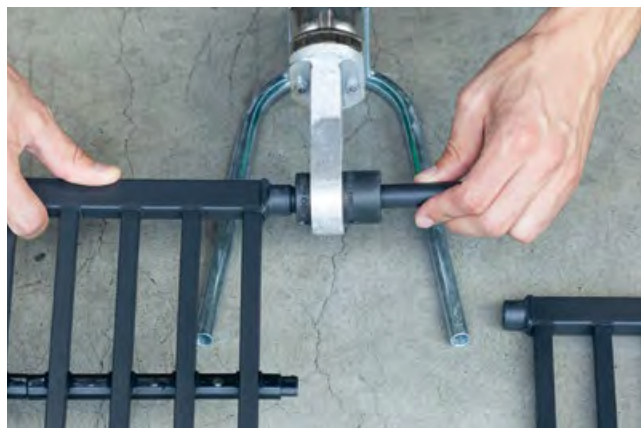

2. Insert heating pipe 16mm into the tool bushing and at the same time push the heating grid socket onto the heating spigot.



3. After the prescribed heat-up time of 5 seconds, pull the parts off the tools ...

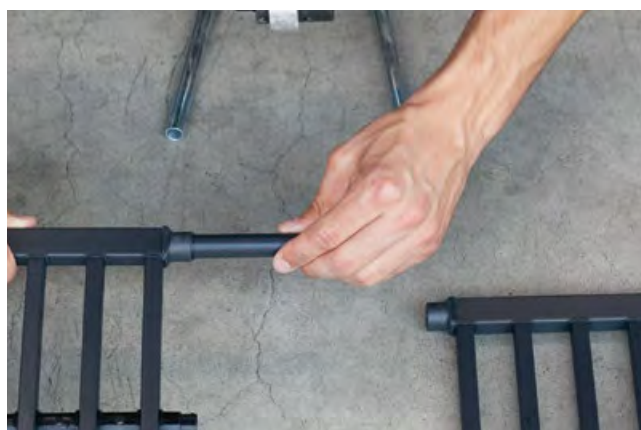

4. ... and push them together immediately (welding depth 13 mm).

Pipe connection to the control zones:

The pipe connection to the respective control zones is made by heating element socket welding.



1. Welding device and tool (16 mm) are mounted; temperature control is performed.



2. Insert elbow 90° female/male (16 mm) into the tool bushing and at the same time push the heating grid socket onto the heating spigot.

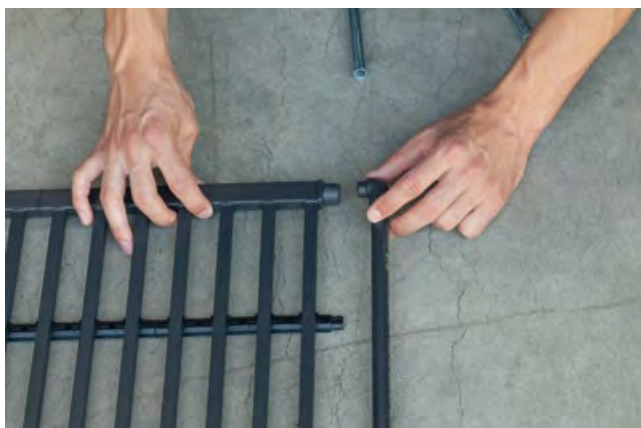

3. After the prescribed heating-up time of 5 seconds, remove the parts from the tools...



4. ... and push them together immediately (welding depth 13 mm)

Connecting technology Part 2: Push-fit connection

aquatherm black system grids with connection types 52 and 62 are simply and securely connected in suspended ceilings by using push-fit connectors. The grids are provided with 16 mm plug-in connections, on which the push-fit connector only must be inserted as far as possible. The holding ring is equipped with stainless steel teeth, keeping the connector firmly in the joint. The two integrated O-rings provide a completely sealed and secure connection.

The holding ring and the O-ring are held in place by a brass locking ring.

General description

In the following, only additional information concerning the cooling and heating ceiling systems is listed:

1. Lay the corrugated connection pipe without tension in the ceiling cavity. Then place the push-fit connector, including safety clip, straight on the plastic grid connection.



2. Press the push-fit connector over the plastic grid connection as far as possible and check the connection with a counter-pull. Care must be taken that the holding element (black ring) does not cant on the nozzle.



Note: When plugging the two components together, hold up with one hand. Without holding-up, deformations at the metal ceiling panel are possible.

3. For visual inspection of the insertion depth, the nozzle is marked (transition from smooth to rough surface). If the insertion depth is correct, the smooth surface of the nozzle is no longer visible. Please check, if the safety ring exists on both push-fit connectors per each corrugated pipe.



Note: If the safety ring is missing, uncontrolled release of the push-fit connector and water leakage may occur. There is no warranty under product liability.

Substructure

When using an on-site substructure, the permissible weight of the substructure must be checked for stability. When calculating the weight of the cooling and heating ceiling, the plastic grids and the water circuits must be considered as "filled".

Connection piping with corrugated pipe

During installation of the metal ceiling panels, the individual plastic grids must be connected to corrugated pipes. The corrugated pipes are equipped with push-fit adapters.

Connection technology part 2: Disassembly of the push-fit connector

4. Before disconnecting the push-fit connector from the nozzle, make sure that the connection is depressurised.
Then pull the red safety clip off the connector.



5. Next, hold the push-fit connector by hand and press the holding ring (black ring) against the connector. As a result, the inner holding ring is opened.



6. Now the push-fit connector can be removed easily from the nozzle.



7. Of course, the connection can be reused several times! The red safety clip must be pushed back before re-attaching.



Alternative attachment for aquatherm black system plastered in wall and ceiling with the battery-actuated fastening tool HILTI BX 3-ME



Applications/advantages

- Fast installation compared to standard fixing (drilling with fixing clamp and wall plug)
- High cost savings for the material
- Quick and easy installation on all suitable surfaces, such as on solid block or concrete
- Versatile fastening system for various applications in the heating and sanitary sector
- High user comfort due to low contact pressure and less noise and recoil
- For driving up to 600 fasteners with a single battery charge

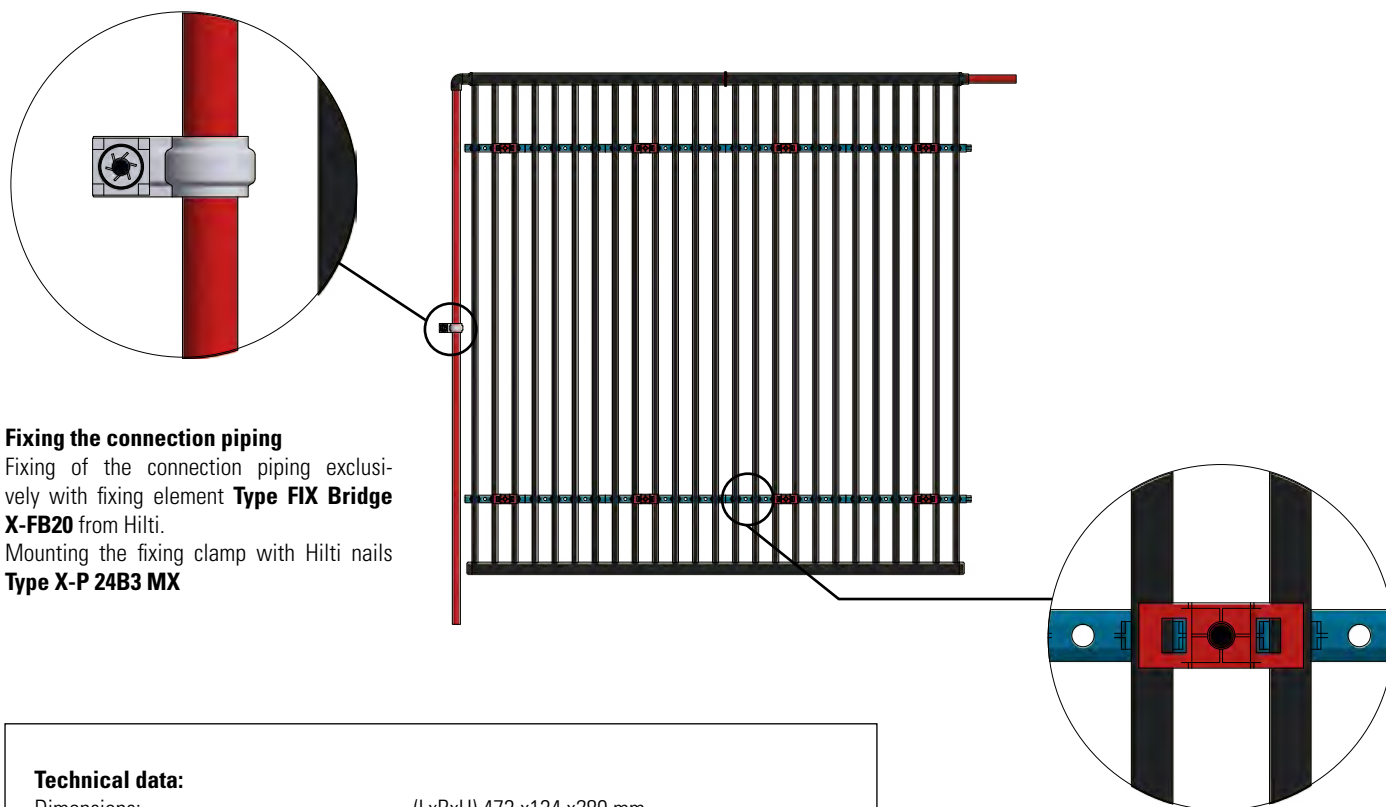

Fixing the connection piping

Fixing of the connection piping exclusively with fixing element **Type FIX Bridge X-FB20** from Hilti.
Mounting the fixing clamp with Hilti nails **Type X-P 24B3 MX**

Technical data:

Dimensions:	(LxBxH) 473 x134 x280 mm
Weight:	3,33 kg
Automatic piston return:	yes
Magazine capacity	20 nails
Nail length:	14 - 36 mm
Maximum fastening rate:	500 / h
Art. no.:	2177435



Accessories:	
Nails for magazine mode:	X-P 24 B3 MX (Art. no. 2156218)
Nails for single fastening mode:	X-P 30 B3 P7 (Art. no. 2105406)
Fixing damper:	X-ET MX (Art. no. 285718)
Fixing element:	Fixbride X-FB MX (Art. no. 286800)

Fixing the grids

aquatherm recommends the installation of 8 fixing rails for drywall (**Art. no. 81298** from aquatherm) per 1 m² grid with the Hilti high performance nailer **Type X-P 30 B3 P7**

CHAPTER CONTROL

Control Method

General description

aquatherm offers a complete system with all the necessary components for optimum control of surface heating or cooling up to the interface of the heating/cooling circuit distributor. Pre-control, switching or mixing valves are not in the delivery program and must be provided externally. This applies to new and old buildings, for integration into existing systems as well as for small areas or large properties.

For surface heating and cooling systems, the individual room control according to EnEV is mandatory, if the object is tempered by this. Only when covering the base load, the individual room control can be dispensed with. Then the peak loads are covered by a separate cooling/heating system with individual room control.

The room temperature control is detected by a room thermostat, which is mounted on the wall. Care must be taken to ensure that the room thermostat is not installed behind curtains, not in drafts or exposed to direct sunlight. The room thermostat activates an actuator in cooling mode when going below and in heating mode when exceeding the pre-set setpoint temperature. The actuator closes or opens the control valve.

In systems that are both heated and cooled, the signal for the central switch-over between heating and cooling mode is given via an automatic management module by a potential-free switching output. If, in cooling mode, the surface temperature of the installed system in the ceiling or wall is below the dew point temperature, this can lead to condensation on the surface. That can be avoided by different alternatives.

Interruption of the volume flow

An external temperature sensor is used to avoid the formation of condensate at critical points, such as directly at the cold water supply. The NTC temperature sensor works in combination with a digitally programmable radio room thermostat with hygrometers (air humidity sensor). Radio room thermostat and NTC temperature sensor permanently monitor the temperature and humidity behavior between the cooling level and the room. As soon as a critical thermal range is reached, the cooling function is stopped and the cooling zone is closed.

Adjustment of the flow temperature (external control)

However, if the performance of the cooling ceiling should not be interrupted, it is possible to adjust the flow temperature depending on the dew point temperature of reference rooms. A control continuously figures the dew point with a humidity and temperature sensor. The flow temperature is thus kept permanently 0.5 K to 1.0 K above the critical temperature. No condensate formation in the room.

In addition to the solutions shown above, the supply of moist air into the room through open windows can be monitored with window contacts. The processing of the "open window" signal must then be integrated into the selected control.

Advice:

Application of dewpoint sensor only on plastic pipes.

Control concept: individual room control heating via radio with zone valve and/or heating circuit distributor

The individual room control heating via radio in the two-pipe system is carried out by a room thermostat with wireless radio transmission. This is switched with an on-site zone valve or the actuators of a heating circuit distributor in order to facilitate the assignment of the individual components and control units. Depending on the version of the radio control distributor, up to 6 room thermostats and 12 actuators can be connected. If required, the radio control distributor can be expanded by up to 4 additional zones and 8 actuators (Art. no. 94422).

Take care to the system voltage, when selecting the components.

Version 1 - via on-site zone valve

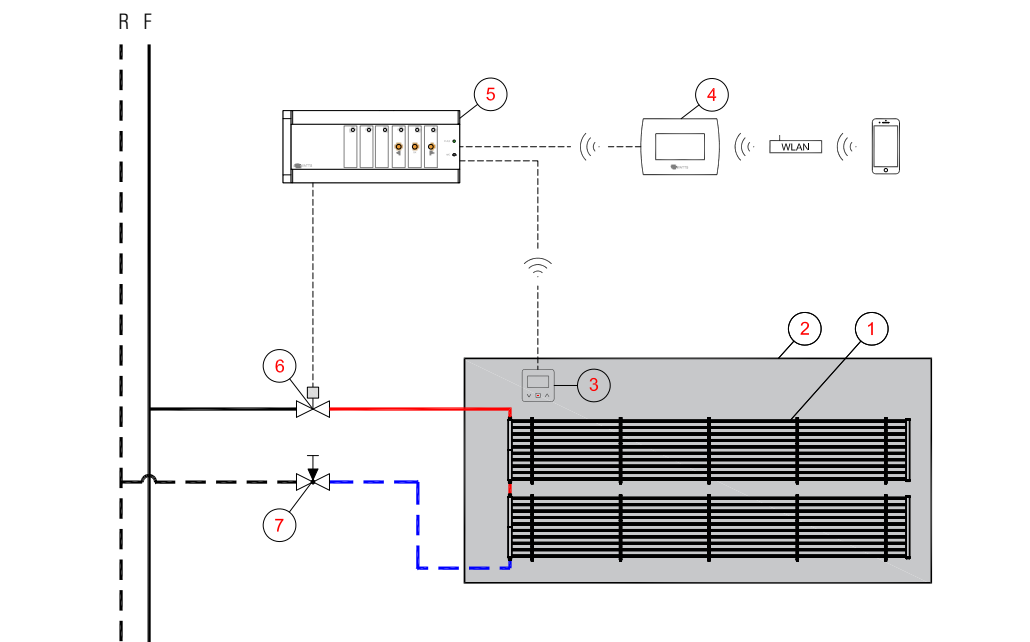

Version 2 - heating circuit distributor

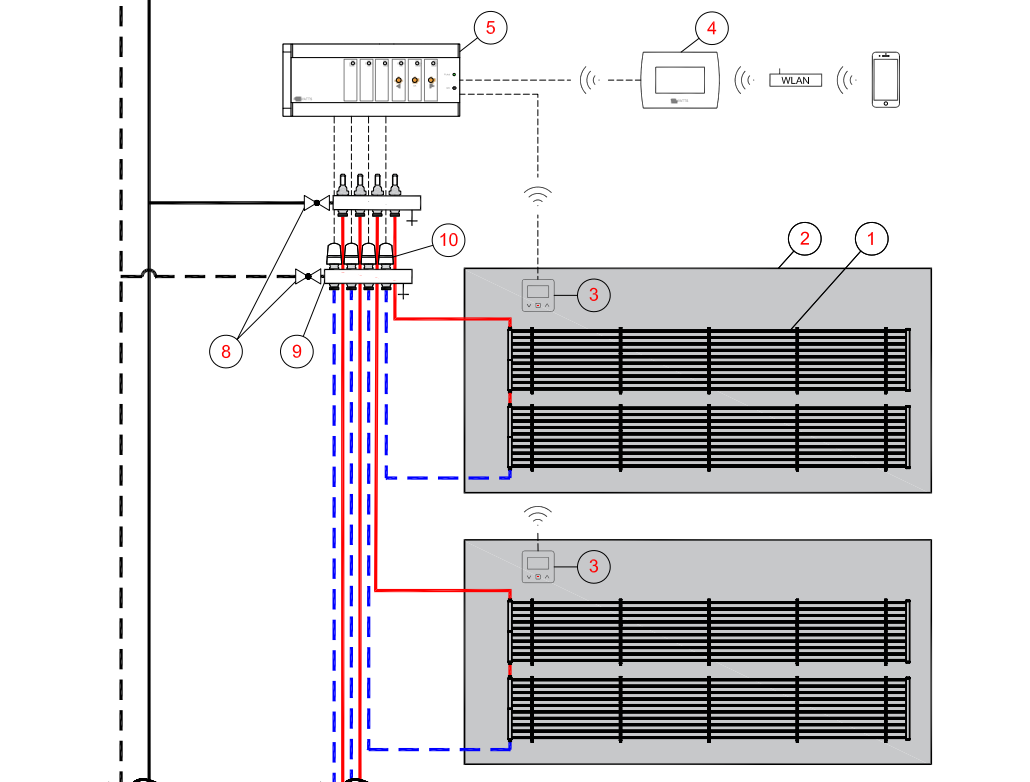

- | | |
|-----------------------------|------------------------------------|
| 1. heating/cooling circuit | 6. zone valve (on-site) |
| 2. control zone | 7. balancing valve (on-site) |
| 3. wireless room thermostat | 8. ball valve set (Art. no. 94413) |
| 4. HUB-WLAN access point | 9. heating circuit distributor |
| 5. multichannel receiver | 10. actuators (Art. no. 94102) |

Control concept: individual room control cooling via radio with zone valve and/or heating circuit distributor

The individual room control heating/cooling in the two-pipe system is carried out via a room thermostat with hygrostats and an external sensor for cooling operation. The room thermostat is switched to a radio control distributor with an on-site zone valve or with the actuators of a heating/cooling circuit distributor in order to facilitate the assignment of the individual components and control circuits. If several connection systems are in use, they can be connected in series using a master-and-slave-function. An external temperature sensor is used to avoid the formation of condensate at critical points, such as directly at the cold water supply. The NTC temperature sensor works in combination with the digitally programmable room thermostat with hygrostats (air humidity sensor). Radio room thermostat and NTC temperature sensor permanently monitor the temperature and humidity behavior between the cooling level and the room. The signal for the central switchover between heating and cooling mode is output via an automatic management module by a floating switching output.

Individual heating and cooling of individual rooms or smaller zones is not possible with this two-pipe system. When selecting the components, pay attention to the system voltage.

Version 1 - via on-site zone valve

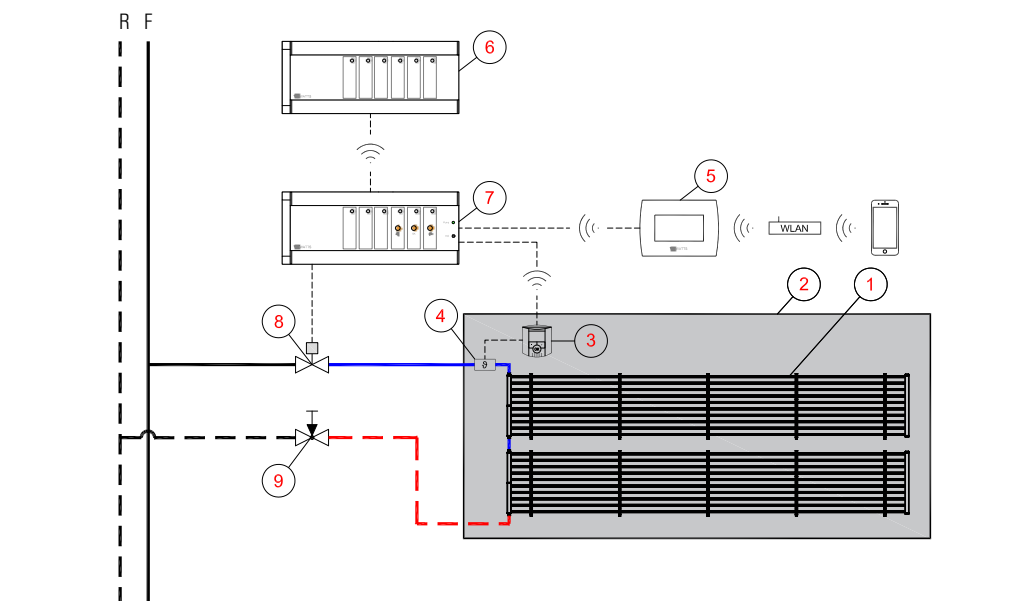

Version 2 - heating/cooling circuit distributor

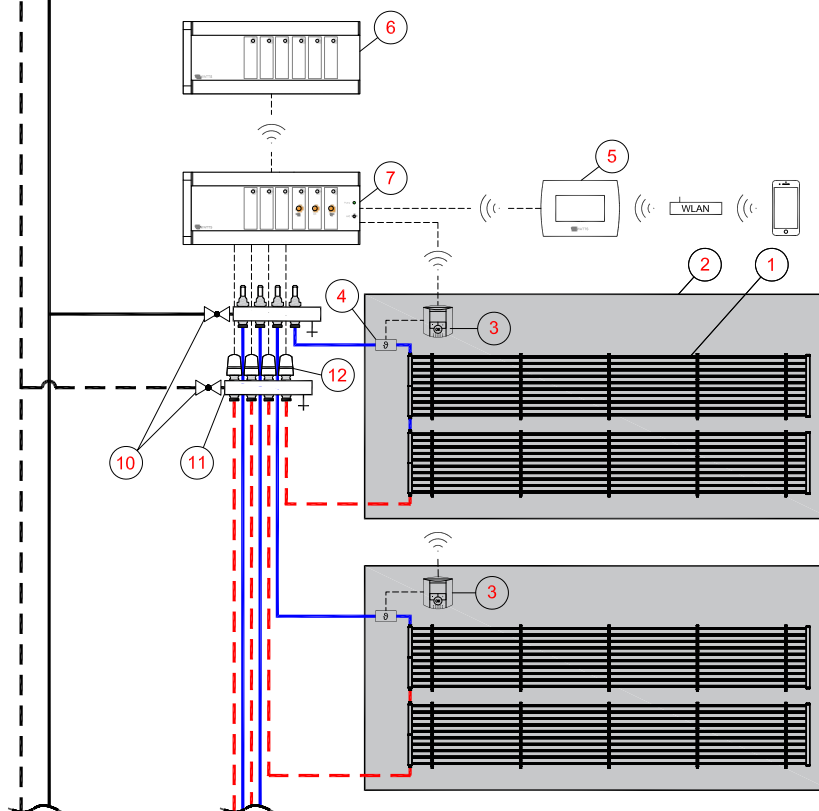

1. heating/cooling circuit
2. control zone
3. radio control distributor (Art. no. 94420)
4. dewpoint sensor (Art. no. 94426)

5. central radio unit (Art. no. 94417)
6. management module (Art. no. 94421)
7. radio control distributor (Art. no. 94422)
8. zone valve (on-site)

9. balancing valve (on-site)
10. ball valve set (Art. no. 94413)
11. heating circuit distributor
12. actuators (Art. no. 94103)

Control concept: individual room control heating via radio with zone valve Connection piping with Tichelmann distributor (short version)

The individual room control heating via Tichelmann distributor with on-site zone valve ensures an even flow through the control circuits. The same lengths of flow and return pipes in the control circuits result in the same pressure losses and volume flows. Room thermostat and zone valve are switched together on a radio control distributor in order to ensure individual and precise control and regulation of the individual control zones.

When selecting the components, pay attention to the system voltage.

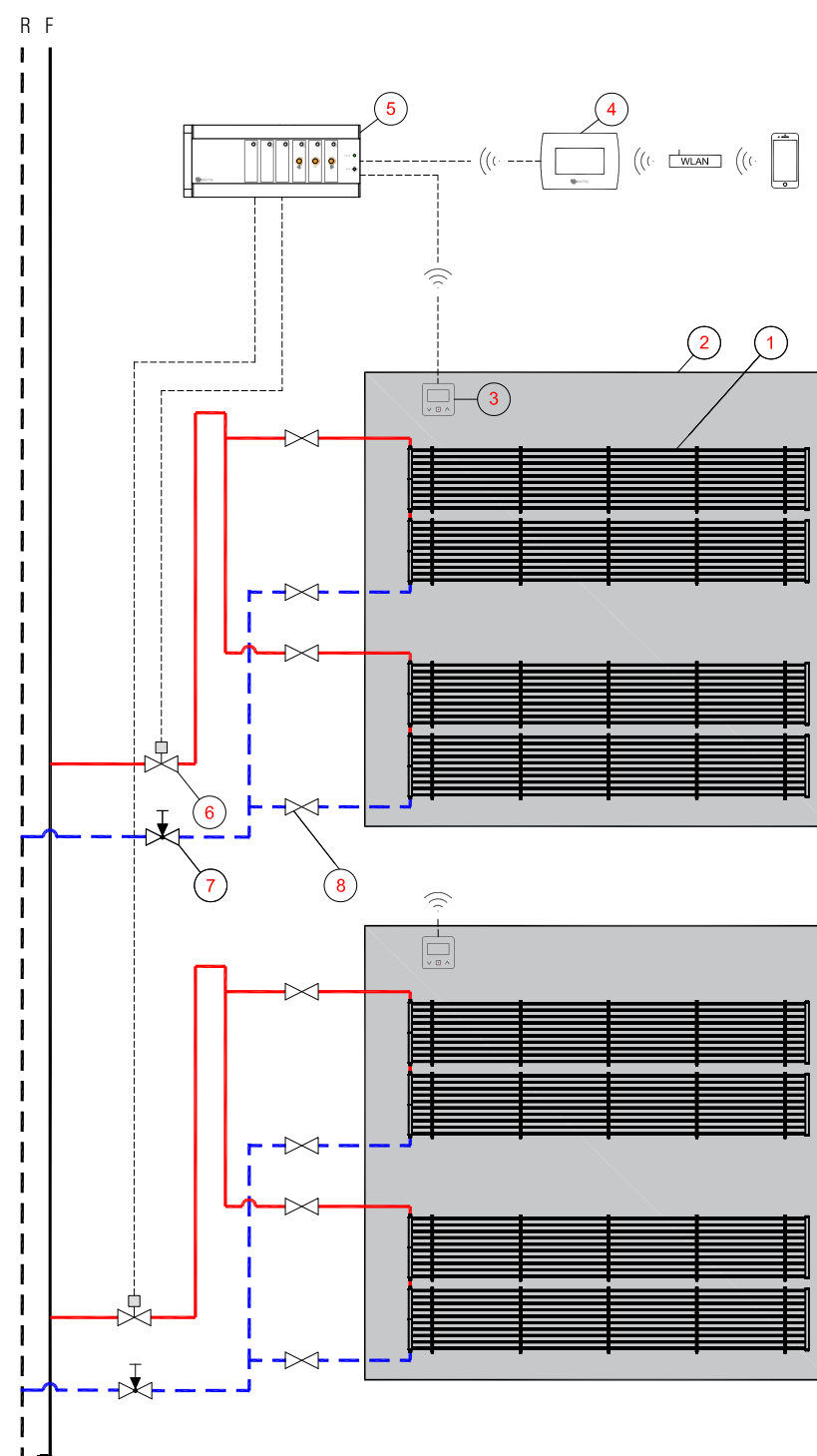

- 1. heating/cooling circuit
- 2. control zone
- 3. radio room thermostat (Art. no. 94418)
- 4. central radio unit (Art. no. 94417)

- 5. radio control distributor (Art. no. 94422)
- 6. zone valve (on-site)
- 7. balancing valve (on-site)
- 8. ball valve / shut-off device

Control concept: individual room control heating/cooling via radio with zone valve Connection piping with Tichelmann distributor (short version)

The individual room control for heating/cooling via Tichelmann distributor with on-site zone valve ensures an even flow through the control circuits. The same lengths of flow and return pipes in the control circuits result in the same pressure losses and volume flows. Room thermostat and zone valve are switched together on a radio control distributor in order to ensure individual and precise control and regulation of the individual control zones. An external temperature sensor is used to avoid the formation of condensate at critical points, such as directly at the cold water supply. The NTC temperature sensor works in combination with the digitally programmable room thermostat with hygrometers (air humidity sensor). Radio room thermostat and NTC temperature sensor permanently monitor the temperature and humidity behavior between the cooling level and the room. The signal for the central switchover between heating and cooling mode is output via an automatic management module via an automatic switching output.

When selecting the components, pay attention to the system voltage.

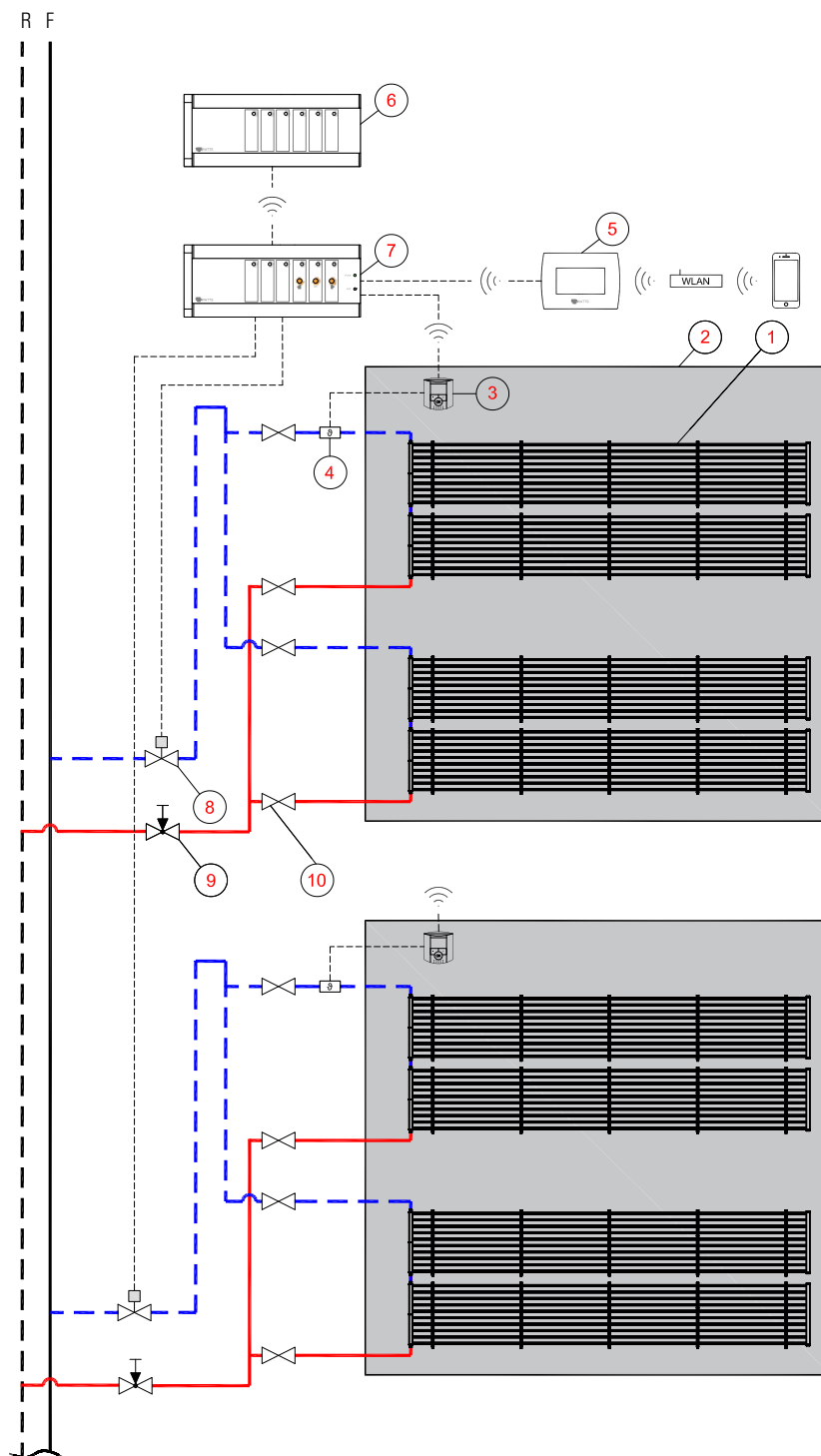

1. heating/cooling circuit
2. control zone
3. radio room thermostat (Art. no. 94420)
4. dewpoint sensor (Art. no. 94426)
5. central radio unit (Art. no. 94417)

6. management module (Art. no. 94421)
7. radio control distributor (Art. no. 94422)
8. zone valve (on-site)
9. balancing valve (on-site)
10. dew point sensor (on-site)

Control concept: individual room control heating/cooling in four-pipe system with room thermostat and 6-way-zone valve

The individual room control for heating/cooling in the four-pipe-system is carried out via a room thermostat with an external temperature sensor for cooling operation and a radio receiver for controlling the on-site 6-way control valve. The room thermostat guarantees via the radio receiver an individual and precise control and needs-based regulation of the heating/cooling ceiling. The 6-way-control ball valve takes over the control function of up to four two-way valves and can optimally regulate different control circuits with an additional balancing valve. Alternatively, an electronically pressure-independent 6-way zone valve ensures the automatic and permanent hydraulic balancing of the control zone and ensures the correct amount of water in the event of changes in differential pressure in part-load operation by means of an electronic flow control.

When selecting the components, pay attention to the system voltage.

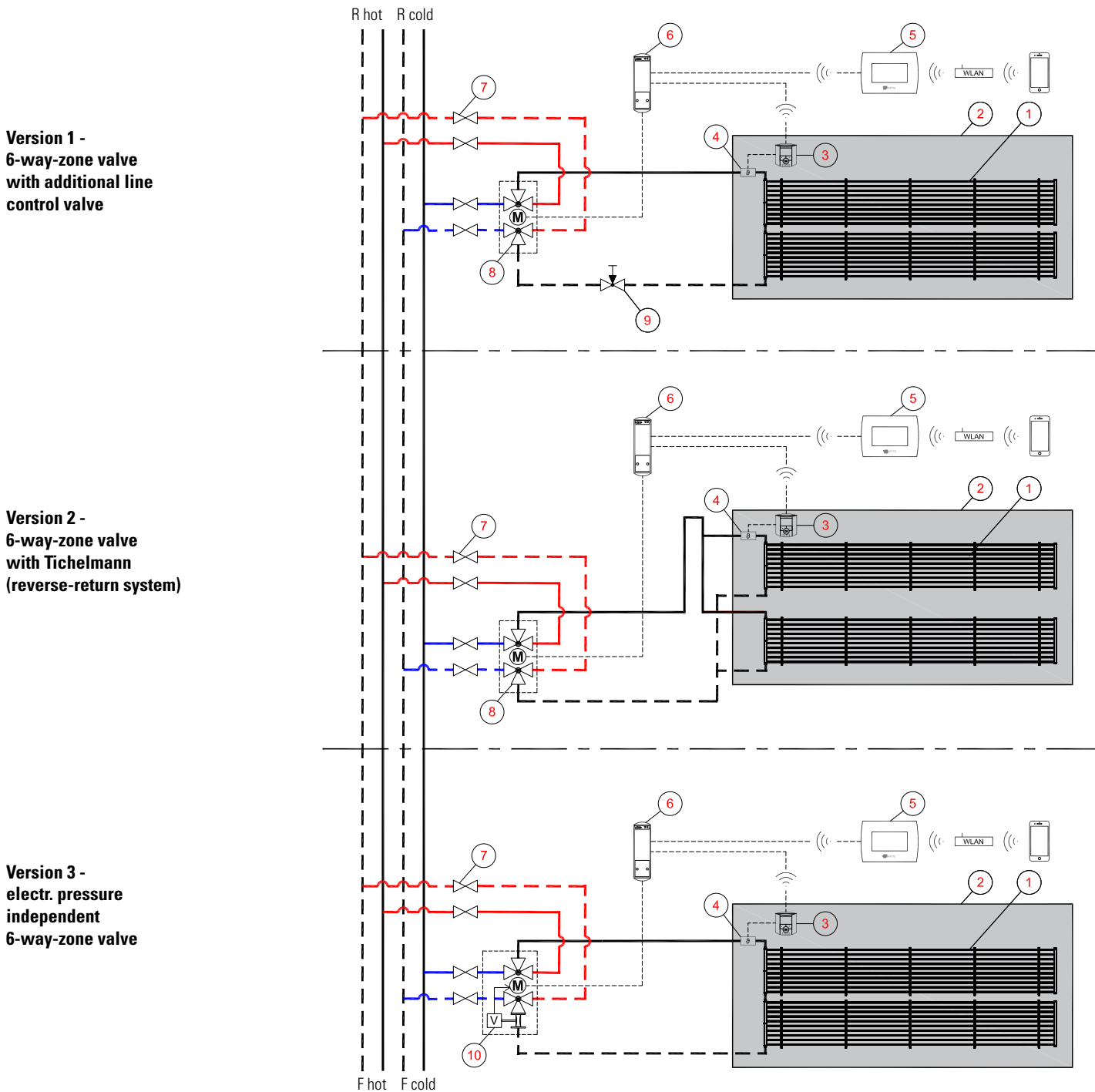

1. heating/cooling circuit
2. control zone
3. radio room thermostat (Art. no. 94420)
4. dewpoint sensor (Art. no. 94426)

5. central radio unit (Art. no. 94417)
6. single radio receiver (Art. no. 94424)
7. ball valve/shut-off device
8. 6-way-zone valve (on-site)
9. line control valve (on-site)

10. electronically pressure independent 6-way-zone valve (on-site)

CHAPTER PLANNING AND DESIGN

Planning and design „Heating and cooling“

Calculation

Generally a heating load calculation acc. to DIN EN 12831 or a cooling load calculation acc. to VDI 2078 has to be performed before designing the aquatherm black system.

$$Q_{\text{Ausl}} = \frac{Q_{\text{H}}}{A_{\text{f}}}$$

Q_{Ausl} = Dimensioning of heat flux density

Q_{H} = Thermal output acc. to DIN EN 12831 less the loss of transmission heat by the components covered by wall heating

A_{f} = Wall surface, covered with wall heating

Graphs

The following output graphs for the aquatherm wall and ceiling heating in wet and dry construction method have to be taken into consideration.

These graphs are valid for

Wet-construction system with wall plaster with thermal conductivity

$$\lambda = 0,35 \text{ W/mK}$$

as well as plaster covering from upper edge of heating pipe

$$= 10 \text{ mm}$$

aquatherm black system dry wall heating element (performance diagram valid in connection with gypsum fibre boards)

$$\lambda = 0,32 \text{ W/mK}$$

Dry wall systems (with dry wall board)

$$\lambda = 0,21 \text{ W/mK Dry wall board}$$

$$\lambda = 0,31 \text{ W/mK Thermoboard Comp. Knauf}$$

$$\lambda = 0,45 \text{ W/mK Thermoboard Plus Comp. Knauf}$$

$$\lambda = 0,516 \text{ W/mK climafit Comp. Rigips}$$

Dry wall systems (with metal panel ceiling)

$$\lambda = 46,5 \text{ W/mK Steel plate}$$

$$\lambda = 200 \text{ W/mK Aluminium}$$

Standards and guidelines

The following standards and guidelines must be considered on planning and design of aquatherm black system:

VDI 2078 cooling load calculation

EnEV Energy saving law

DIN EN 1264 Surface heating systems

DIN 1186 Construction gypsums

DIN 4102 Fire protection in building construction

DIN 4108 Heat Insulation in building construction

DIN 4109 Sound Insulation in building construction

DIN EN 12831 Calculation of the standard heating load

DIN EN 1264 Hot water underfloor heating

DIN 4726 Conduits of plastic

DIN 18164 Foam plastics

DIN 18165 Fibre insulating materials

DIN 18180 Gypsum plasterboards

DIN 18181 Gypsum plasterboards in building construction

DIN 18182 Accessories for the processing of plasterboards

DIN 18195 Building sealing

DIN 18202 Dimension tolerances in building construction

DIN 18350 Plastering works and stucco works

DIN 18557 Mortar

DIN 18550 Plasters

(Individual processing guidelines of the respective manufacturer)

Planning and design „Heating and cooling“

Design of aquatherm black system ceiling cooling

For the standard installation situation of aquatherm black system ceiling cooling there are standard cooling efficiencies available, according to DIN EN 14240 2004-04.

As the standard cooling efficiency is measured under test conditions, it must be adapted under real conditions. The room conditions (height), the influence of the outside façade with high surface temperatures, the influence of the ventilation on the convective heat transmission of the cooling ceiling and the ventilation of the cooling ceiling by an open shadow gap belong to this.

The influence of these parameters can increase the real cooling efficiency of an aquatherm black system cooling ceiling compared with the standard cooling efficiency by 6 – 10%.

Example cooling ceiling

Room:		Office
Room temperature:	ϑ_i	26 °C
Cooling load:	Φ_{Ber}	945 Wat
Ceiling:	λ	0,31 W/mK (Thermoboard Comp. Knauf)
Standard cooling efficiency ceiling:		63 W/m ² *
Required grid area:		15,0 m ²
Flow:	ϑ_v	15 °C
Return:	ϑ_R	17 °C
Linear temperature difference:	$\Delta\vartheta_H$	10 K

$$\Delta\vartheta_H = \vartheta_i - \left(\frac{\vartheta_v + \vartheta_R}{2} \right)$$

Design of aquatherm black system ceiling and wall heating

Room:		Office
Room temperature:	ϑ_i	20 °C
Heating load:	Φ_{Ber}	750 Watt
Ceiling:	λ	0,31 W/mK (Thermoboard Comp. Knauf)
Standard heating efficiency:		50 W/m ² *
Required grid area:		15,0 m ²
Flow:	ϑ_v	32° C
Return:	ϑ_R	27° C
Linear temperature difference:	$\Delta\vartheta_H$	9,5 K

$$\Delta\vartheta_H = \left(\frac{\vartheta_v + \vartheta_R}{2} \right) - \vartheta_i$$

*see graph for the standard cooling and heating of the individual systems

Mass flow of aquatherm black system heating and cooling grids

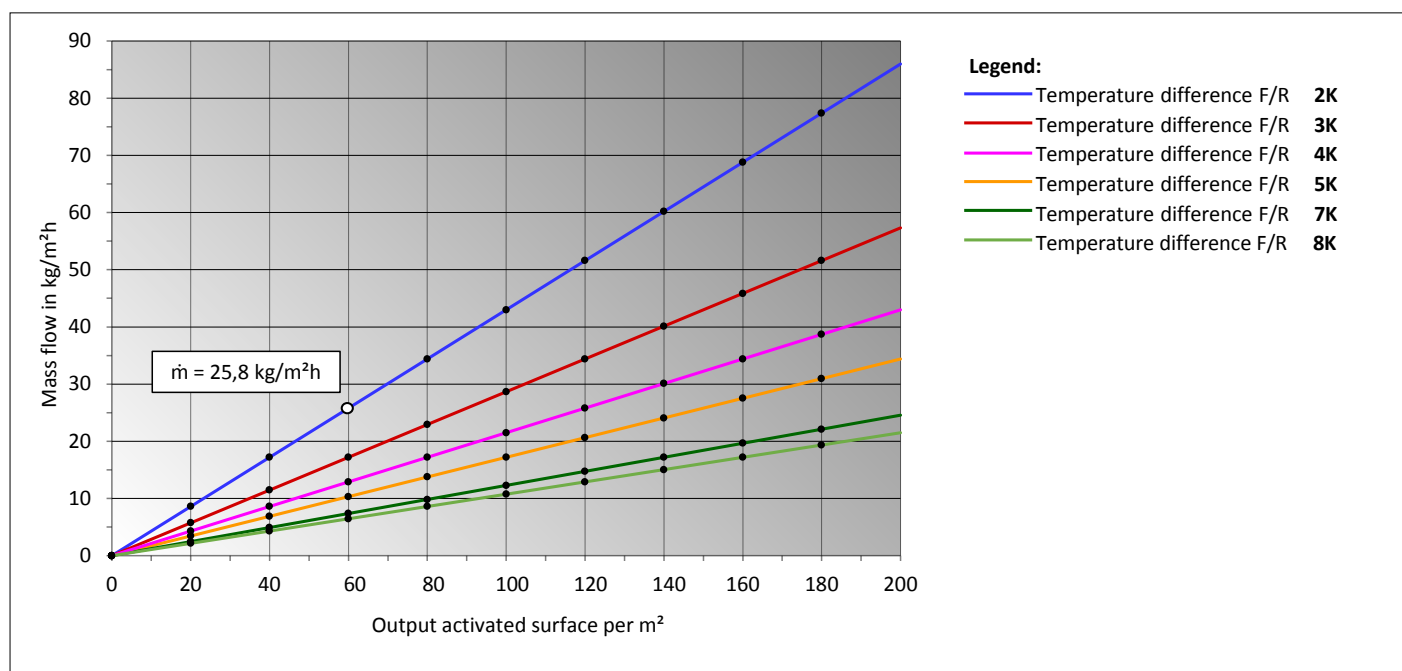

Mass flow determination for the grid area per m²:

Example:

output activated surface per m²:

$$Q_{\text{spec.}} = 60 \text{ W/m}^2$$

active zone occupied with grids:

$$A_{\text{active zone}} = 6,20 \text{ m}^2$$

spread:

$$\Delta\theta = 2 \text{ K}$$

output of the active zone:

$$Q_{\text{active zone}} = A_{\text{active zone}} * Q_{\text{spec.}}$$

$$Q_{\text{active zone}} = 6,20 \text{ m}^2 * 60 \text{ W/m}^2$$

$$Q_{\text{active zone}} = 372 \text{ W}$$

mass flow of the active zone:

$$\dot{m}_{\text{active zone}} = \frac{Q_{\text{active zone}}}{c * \Delta\theta}$$

$$\dot{m}_{\text{active zone}} = \frac{372 \text{ W}}{1,163 \frac{\text{Wh}}{\text{kg} * \text{K}} * 2 \text{ K}}$$

$$\dot{m}_{\text{active zone}} = 159,90 \text{ kg/h}$$

specific mass flow per m²:

$$\dot{m}_{\text{spec.}} = \frac{\dot{m}_{\text{active zone}}}{A_{\text{active surface}}}$$

$$\dot{m}_{\text{spec.}} = \frac{159,90 \text{ kg/h}}{6,20 \text{ m}^2}$$

$$\dot{m}_{\text{spec.}} = 25,80 \text{ kg/m}^2\text{h}$$

Pressure loss graph of aquatherm black system heating and cooling grids

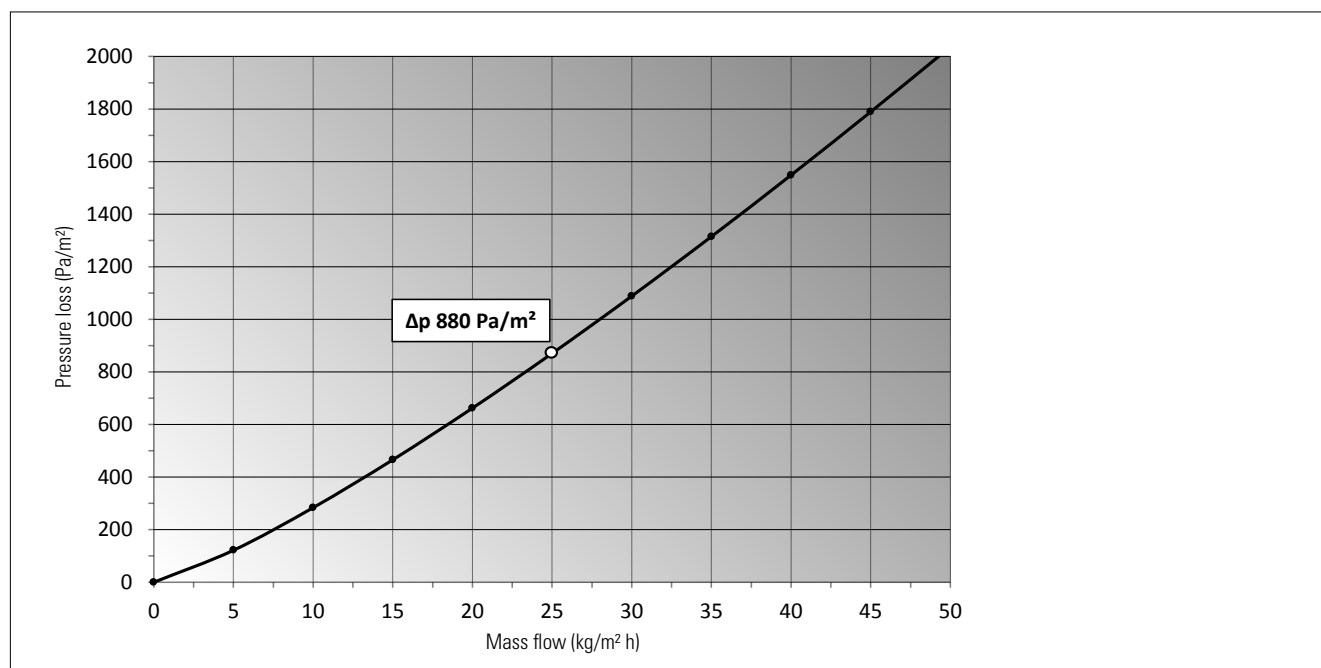

Pressure loss determination for the grid area per m² and zone

Example

specific pressure loss per m²:
(see graph)

$$\Delta p_{\text{spec.}} = 880 \text{ Pa/m}^2$$

pressure loss per zone:

$$\Delta p = \Delta p_{\text{spec.}} * A_{\text{active zone}}$$

$$\Delta p = 880 \text{ Pa/m}^2 * 6,20 \text{ m}^2$$

$$\Delta p = 5.456 \text{ Pa (54,56 mbar)}$$

Pressure loss graph Pressure loss pipe 16x2 mm

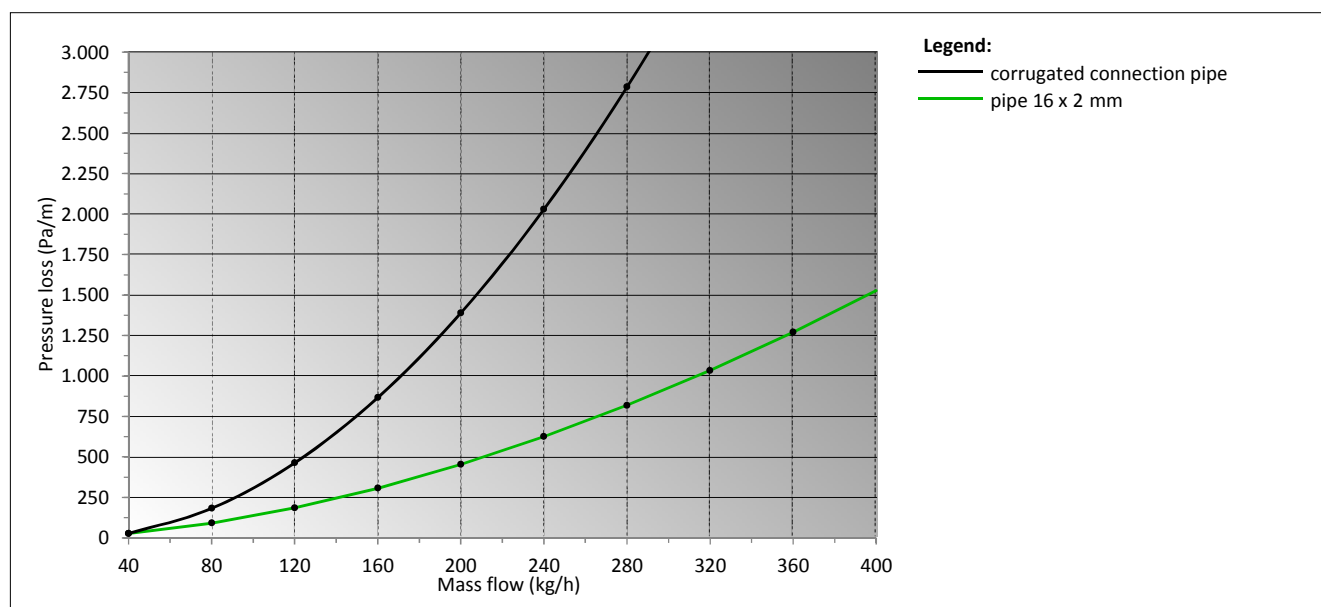

CHAPTER START-UP AND TEST RECORDS



Start-up

Flushing, filling and venting

Basically, the aquatherm black system must be pressurized prior to plaster or panelling work. Therefore, the pipes must be flushed and filled in zones at the heating circuit distributors e.g. by filling and drain valves. Due to the self-venting effect of the grids, the air is flushed out of the system through correct filling via the pipes. With a low volume flow and low filling pressure (max. 0.5 bar) water is filled into the system until it leaves bubble-free. Generally, wall heating must be filled from the bottom to the top, i.e. via the return pipe. The hydraulic balancing of the system must be regulated according to the calculation.

Leak test

According to DIN EN 1264-4, aquatherm black system is to be tested for leaks like the underfloor heating systems.

The test pressure must be twice the operating pressure, at least 4 bar but not more than 6 bar. To ensure the permanent tightness, the system must be pressed off in intervals. The system must be charged for one hour with the test pressure. Then the system is depressurized. Now the system is charged with a pressure of 1 bar for 15 minutes. After the system is depressurized again, the process is repeated twice. This test pressure must be kept during the plaster works at the wall or ceiling or during the panelling works.

The tightness and the test pressure must be recorded in a test record (see page 111). If there is a risk of freezing, suitable measures like the use of anti-freezer or heating of the building should be applied. The anti-freezer must be removed by draining and flushing with at least three changes of water, if no anti-freezer is required for normal operation of the system.

Functional heating

- 1) Functional heating for wet installed surface heating and/or surface heating and cooling systems

The functional heating must be performed to check the heated or cooled wall or ceiling construction. It serves the heating engineer as evidence for the construction of a defect-free product. Depending on the thickness and the bonding agent of the heat distribution layer, the following minimum drying times must be kept before heating up the system:

Lime cement:	1 day per mm layer thickness
Lime:	1 day per mm layer thickness
Gypsum:	1/2 day per mm layer thickness
respectively:	___ days according to manufacturer's instructions

- 2) Functional heating for surface heating and cooling system as dry system

The functional heating must be performed to check the function of the heated or cooled wall or ceiling construction. The functional heating of dry systems is performed after finishing the filling or bonding work. Filler or adhesive must be cured. Manufacturer's instructions must be observed.

Test records for functional heating of wet and dry systems are on page 109 and 110.

Functional heating as functional test

Functional test for wet installed surface heating and/or surface heating and cooling systems (for wall and ceiling)

Client: _____

Building /Property: _____

Building section
Floor/Flat: _____

Plant section: _____

Requirements

The tightness of the heating/cooling circuits of surface heating/surface cooling (thermally tested and certified surface system and pipe system) is assured by a water pressure test immediately before laying the screed, plaster or levelling compound. The test pressure is here, deviating from the VOB C (DIN 18380), at least 4 bar and not more than 6 bar. This pressure must be maintained during the application of the screed/plaster.

Lime cement: 1 day per mm layer thickness
Lime: 1 day per mm layer thickness
Gypsum: 1/2 day per mm layer thickness
respectively: ___ days according to manufacturer's instructions

The leak test is carried out in sections after flushing the individual heating circuits. It must be ensured that other parts of the system are protected from excessive pressure (if necessary, by means of main shut-offs in front of the distributor). Alternatively, the leak test can also be carried out with compressed air. The test pressure here is differing to a maximum of 3 bar.

Documentation

- 1) Type of heat distribution layer (product, if indicated): _____
bonding agent: _____
- 2) End of works at heat distribution layer (date): _____
- 3) Start of functional heating (date): _____
with constant max. calculated flow temperature $t_v = \text{_____}^\circ \text{C}$
- 4) End of functional heating (date): _____
In case of frost risk protective measures must be applied.
- 5) The rooms have been vented without draft and all windows and external doors have been closed after disconnection of the surface heating and cooling system.
 yes no
- 6) The system has been released for further construction works at an outside temperature of _____ °C.
 In that process the system was out of action.
 The heat distribution layer was heated with a flow temperature of _____ °C.

Confirmation

.....
Place/Date

.....
Place/Date

.....
Place/Date

.....
Owner/Client
Stamp/Signature

.....
Constructor/Architect
Stamp/Signature

.....
Heating engineer
Stamp/Signature

Functional heating as functional test

Functional test for dry installed surface heating and cooling systems

Client: _____

Building/Property: _____

Building section
Floor / Flat: _____

Plant section: _____

Requirements

The functional heating must be performed for checking the function of the heated respectively cooled underfloor, wall or ceiling construction. In case of dry systems the functional heating is made after finishing of the spattle or bonding works. Surfacers resp. bonding must be cured. Manufacturers' instructions must be observed.

The maximum calculated flow temperature (normally up to 45° C) must be kept for 1 day. If there is any risk of frost, the system should be kept in operation. Manufacturers' instructions, notwithstanding the standard or this record, must be observed.

Documentation

- 1) Type of heat distribution layer (product, if indicated): _____
bonding agent: _____
- 2) End of works at heat distribution layer (date): _____
- 3) Start of functional heating (date): _____
with constant max. calculated flow temperature $t_v = \text{_____}^\circ \text{C}$
- 4) End of functional heating (date): _____
In case of frost risk special precautions should be applied.
- 5) The rooms have been vented without draft and all windows and external doors have been closed after disconnection of the surface heating and cooling system.
 yes no
- 6) The system has been released for further construction works at an outside temperature of _____°.
 In that process the system was out of action.
 The heat distribution layer was heated with a flow temperature of _____° C.

Note: When disconnecting the surface heating after the heating-up, the heating surface must be protected from draft and rapid cooling down up to its full cooling.

Confirmation

.....
Place/Date

.....
Place/Date

.....
Place/Date

.....
Owner/Client
Stamp/Signature

.....
Constructor/Architect
Stamp/Signature

.....
Heating engineer
Stamp/Signature

LEAK TEST OF SURFACE HEATINGS AND SURFACE COOLINGS**Test record**

Client: _____

Building/Property: _____

Building section Floor / Flat: _____

Requirements

The tightness of the heating/cooling circuits of surface heating/surface cooling (thermally tested and certified surface system and pipe system) is assured by a water pressure test immediately before laying the screed, plaster or levelling compound. The test pressure is here, deviating from the VOB C (DIN 18380), at least 4 bar and not more than 6 bar. This pressure must be maintained during the application of the screed/plaster.

The leak test is carried out in sections after flushing the individual heating circuits. It must be ensured that other parts of the system are protected from excessive pressure (if necessary, by means of main shut-offs in front of the distributor).

Alternatively, the leak test can also be carried out with compressed air. The test pressure here is differing to a maximum of 3 bar.

Maximum allowable operating pressure 4 resp. 6 bar**Principle test****1. Operation pressure 6 bar**

Pressure after 60 Min. _____ bar

2. Operation pressure 1 bar

Pressure after 15 Min. _____ bar

Interval test**1. Operation pressure 6 bar _____ bar**

minimum 60 Min., then

Operation pressure 1 bar _____ bar

minimum 15 Min.

2. Operation pressure 6 bar _____ bar

minimum 60 Min., then

Operation pressure 1 bar _____ bar

minimum 15 Min.

Between each cycle the pipe must be depressurized

The tightness was detected; no permanent deformations occurred at any structural element.

Confirmation.....
Place/Date.....
Place/Date.....
Place/Date.....
Owner/Client
Stamp/Signature.....
Constructor/Architect
Stamp/Signature.....
Heating engineer
Stamp/Signature



aquatherm

state of the pipe

EXPLANATORY COMMENTS ON THE AQUATHERM GMBH WARRANTY

1. Foreword

Thank you very much for making the decision to use a product from aquatherm GmbH, Germany (herein referred to as "aquatherm"). With more than 45 years of experience in the international plastic pipes market, and our trendsetting innovations, we have the expertise needed to offer you engineered piping solutions made in Germany.

The trust placed in the quality of our products has motivated us to offer all pipes and molded, fabricated, machined, and/or assembled parts with a 10-year warranty instead of the standard 2-year warranty required by German law. This extended time covered by warranty is backed by a comprehensive insurance policy from a leading insurance company for our line of business. The warranty period will begin with the date of delivery by aquatherm GmbH, but only comes valid with the successful pressure test, which must be carried out and documented in accordance with the aquatherm specification.

2. Scope of warranty

The aquatherm warranty protects you from financial loss proven to be caused by material defects, manufacturing defects and/or aquatherm's consulting/engineering services. The warranty coverage shall apply for the following product groups:

- aquatherm green pipe (fusiotherm and aquatherm ISO)
- aquatherm blue pipe (climatherm and aquatherm ISO)
- aquatherm red pipe (firestop)
- aquatherm black system (climasystem)
- aquatherm lilac pipe (aquatherm lilac)
- aquatherm orange system (aquatherm heating systems)
- aquatherm grey pipe (aquatherm SHT system)
- assemblies fabricated by aquatherm from these product groups

2.1 What is covered by the aquatherm warranty?

The aquatherm warranty covers three aspects of damages: property damage, financial loss and personal injury.

2.1.1 What is property damage?

The damage to or destruction of a tangible item as a result of a defective product (e.g. classic water damages as a result of a leak). As a result of this, the suitability of the tangible item to fulfill its actual purpose is impaired. The term property damage is used if tangible items are damaged or destroyed. Considerable costs can be incurred as a result of property damage, such as renovation costs, repair costs or replacement costs.

2.1.2 What is meant by financial loss?

Financial loss may either be out-of-pocket loss or loss of business. Out-of-pocket financial loss is for example the costs of removing products and installing replacements after damage. Loss of business is the financial disadvantage suffered by an injured party as a result of a damaging event (e.g. lost income as a result of renovations following property damage).

2.1.3 What is meant by personal injury?

If a person suffers physical injury, this is known as personal injury. For the purposes of this document, the coverage of personal injury means the direct medical costs incurred as a result of the injury.

3. What is not covered?

Costs related to the damages incurred such as a result of:

- Non-compliance with the operating parameters defined and specified by aquatherm as found in aquatherm's technical documents. In cases of doubt, contact your local aquatherm manufacturer's rep. Exceptions must be provided for, in writing, by a member of aquatherm's engineering team.
- Non-compliance with the installation guidelines as set out in the aquatherm Catalogue, with emphasis to the required installation of aquatherm propriety clipping or other compatible with aquatherm piping.
- Non-compliance with respective National Plumbing Standards and Regulations.
- Joints which were not made in accordance with the aquatherm guidelines, including but not limited to: improper fusion technique, use of contaminated materials or tools, use of faulty or unsuitable tools, use of damaged materials or tools, or any connection made by an installer without sound knowledge of the aquatherm connection techniques and their processes.
- Improperly assembled connections to other pipeline systems and/or components (threads, flanges, stubs, mechanical joints not intended for use with aquatherm PP piping etc.).
- All sealing elements used in the product lines manufactured by aquatherm.
- Tools and accessories sold by aquatherm GmbH are covered for the warranty period by law under the statutory warranty provisions.
- Systems with defective pipeline sections or fittings that were not subjected to the aquatherm pressure test or alternative testing approved by aquatherm prior to start-up.
- Damage to our products caused by incorrect handling after the material has left aquatherm's possession.
- Damage caused or exacerbated by copper in the water resulting from erosion/corrosion or other degradation of copper components in a domestic hot water recirculating system.
- Time delay, caused by incorrect planning, delivery problems and/or incorrect orders.
- Damage caused by entrained air, cavitation and pressure fluctuations.

Note: This list only includes the most prominent examples. Other circumstances, which compromise the integrity of the products, may also jeopardize the coverage.



aquatherm

state of the pipe

EXPLANATORY COMMENTS ON THE AQUATHERM GMBH WARRANTY

4. How is the amount of compensation under the aquatherm warranty determined?

In the event of a material failure, samples of the damaged/faulty product are collected by the national aquatherm partner to forward them to aquatherm GmbH for examination and analysis. Working in collaboration with the injured party, aquatherm will identify the cause of the damage, and call in external bodies (test institutes, laboratories, assessors, etc.) as needed. If the damage has been caused by a material and/or manufacturing defect or by aquatherm's consulting/engineering services, the underwriter shall quantify the compensation claim for damages. All expenditures associated with the damages for this claim must be verified/recorded in detail and in a verifiable format as a required measure.

5. How much is the maximum coverage?

For the first 5 years of the warranty period, property damage, personal injury and financial loss is covered for the sum of €20 million per insurance claim. Total coverage for all claims made in a year is a maximum of €40 million. For years 6-10 of the warranty period, these coverage amounts are €7.5 and €15 million respectively.

6. Why is the coverage stated in Euro?

The insured manufacturer, aquatherm, as well as the insurer, are both based in the EU, so that their agreements are issued in Euros (€). Since exchange rates fluctuate, the exchange rate current on the date of compensation shall apply.

7. What is the channel of communication for notifying claims under warranty and making inquiries about them?

Warranty claims have to be made to aquatherm via the national aquatherm GmbH partners. Information about the progress of the claim will only be released by the aquatherm partner or aquatherm GmbH.

8. Legal note

If a discrepancy or conflict arises between this document and the underlying insurance policy, the latter shall in all cases prevail.

9. Information about avoiding damage

I) **Manufacture under certified quality level**

As a trusted manufacturer, aquatherm works to a certified quality standard (ISO 9001); constant internal quality controls are part of the daily routine. In addition to this, all employees are integrated into a quality assurance program. As a result of this, products failing to comply with our high standards are quickly identified and removed from our product range.

II) **Preventing damage caused by incorrect handling**

Our products must be handled conscientiously and carefully when they are delivered from our production plants. Experience shows that most damage is caused in transit, storage and/or when working on site. At this point we would draw close attention to the fact that correct handling contributes to maintaining the product quality.

III) **Work is to be carried out by qualified installers**

Installation defects are easy to avoid. Our training courses teach the correct techniques in detail for working with our products. In doing so, particular importance is attached to work being carried out attentively and with care. The work of installers trained by us or our aquatherm partners is much more reliable and carried out much more efficiently.

For a safe connection, we recommend using only aquatherm PP products in a piping system. Mixing with other PP piping systems should be avoided.

March 2020
aquatherm GmbH, Biggen 5, 57439 Attendorn, Germany

PRODUCT LIST

SYSTEM PLUG & PLAY**Application: metal panel**

The Plug & Play high-performance modules consist of grid, heat conducting plates and aluminium carrier plate.

They are either inserted mechanically into the metal panel at factory and delivered to the site as a complete package (system „activated“) or they are activated directly on site by manually pushing the modules into the existing metal panel (system „solo“). Retrofitting is also possible.

Panel size [mm]	Total module width [mm]	Associated grid width [mm]
> 300 bis ≤ 400	300	240
> 400 bis ≤ 500	400	360
> 500 bis ≤ 600	500	400
> 600 bis ≤ 700	600	520
> 700 bis ≤ 900	700	600
> 900	900	800

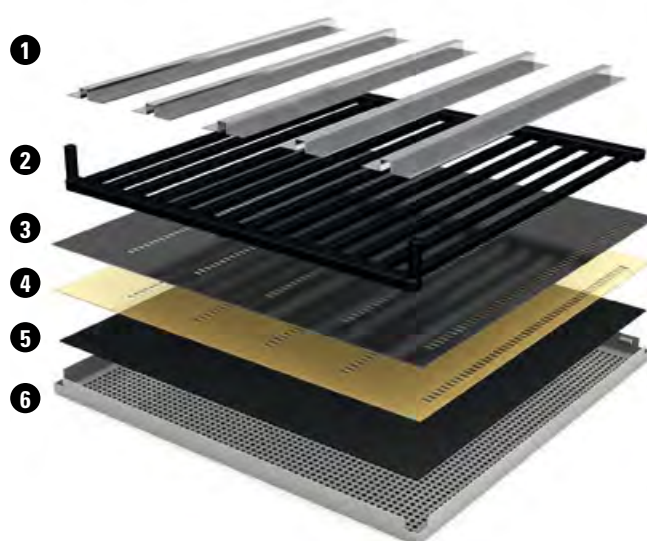

1. Heat conducting plates
2. Heating/cooling grid
3. Carrier plate (adhesive active)
4. Protective film (removed when bonding)
5. Acoustic fleece
6. Metal panel

SYSTEM WLT**Application: metal panel**

The grids are installed in the factory with aluminium heat-conducting sheets in metal panels. The activated metal panels are delivered directly to the site. The finished metal panel elements only have to be hooked into the associated substructure and hydraulically connected.

Grid width [mm]	Total module width [mm]
240	265
280	305
320	345
360	385
400	425
480	505
520	545
560	585
600	625
680	705
800	825
1000	1025



1. Heat conducting plates
2. Heating/cooling grid
3. Acoustic fleece
4. Metal panel

SYSTEM DRYWALL-HLM

Application: drywall plasterboard ceilings

The aquatherm black system high-performance drywall HLM modules consist of grid, heat conducting sheets and aluminium carrier plate. The aluminium carrier plate is perforated for use in the field of acoustic ceilings (perforated plasterboards ceilings) to ensure optimal sound absorption. The assembly of the high-performance drywall HLM modules is very simple: The modules are hooked into the supporting profiles of the substructure. Then the ceiling is covered with buildings boards. For this, e. g. plasterboards and perforated plasterboards with different thermal conductivities can be used.

Centre distance substructure [mm]	Total module width [mm]	Associated grid width [mm]
333	263	240
400	330	320
500	430	400



1. Heat conducting plates
2. Heating/cooling grid
3. Carrier plate (closed or perforated)

ARTICLE STRUCTURE

Available lengths: 600 up to 2500 mm

Graduation identical to aquatherm black system standard (see following page)

Special sizes and lengths up to 5.0 m on request!

System		Connection types	
Plug & Play	Solo (Installation on metal panel on site)	("43" xx xxx)	("44" xx xxx)
	Activated (Pressed directly onto metal panel ex works)	("45" xx xxx)	("46" xx xxx)
WLT		("31" xx xxx)	("32" xx xxx)
Drywall-HLM	Drywall with substructure Distance: 333 mm	("36" xx xxx)	("37" xx xxx)
	Drywall with substructure Distance: 400/500 mm	("38" xx xxx)	("39" xx xxx)

Composition of the article numbers:

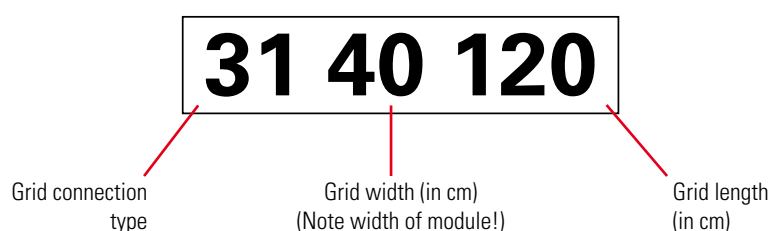







aquatherm black system HEATING AND COOLING GRIDS

oxygen-tight (incl. fixing rails depending on the type of connection)

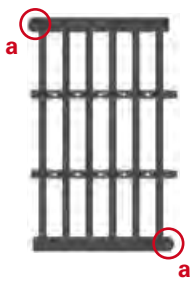
Attention:

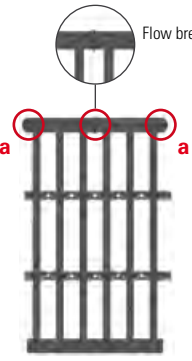
All grids are available in the mentioned connection types at same prices.

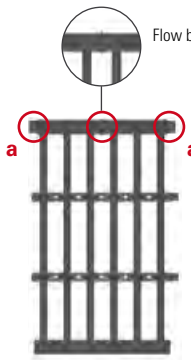
Simply replace the first two figures of the article number („52“xxxx) with those of the required type of connection (i. e. „62“ or „64“).

Connection types of the grids			Art. no.	Width [m]	Length [m]	Area [m ²]	PU	Price € pc
52	62	64						
  Detail of connection a	  Detail of connection a	  Detail of connection a	52 24040	0,24	0,40	0,10	1	
			52 24050	0,24	0,50	0,12	1	
			52 24060	0,24	0,60	0,14	1	
			52 24070	0,24	0,70	0,17	1	
			52 24080	0,24	0,80	0,19	1	
			52 24090	0,24	0,90	0,22	1	
			52 24100	0,24	1,00	0,24	1	
			52 24120	0,24	1,20	0,29	1	
			52 24140	0,24	1,40	0,34	1	
			52 24160	0,24	1,60	0,38	1	
52 24180	0,24	1,80	0,43	1				
52 24200	0,24	2,00	0,48	1				
52 24225	0,24	2,25	0,54	1				
52 24250	0,24	2,50	0,60	1				
			52 28040	0,28	0,40	0,11	1	
			52 28050	0,28	0,50	0,14	1	
			52 28060	0,28	0,60	0,17	1	
			52 28070	0,28	0,70	0,20	1	
			52 28080	0,28	0,80	0,22	1	
			52 28090	0,28	0,90	0,25	1	
			52 28100	0,28	1,00	0,28	1	
			52 28120	0,28	1,20	0,34	1	
			52 28140	0,28	1,40	0,39	1	
			52 28160	0,28	1,60	0,45	1	
			52 28180	0,28	1,80	0,50	1	
			52 28200	0,28	2,00	0,56	1	
			52 28225	0,28	2,25	0,63	1	
			52 28250	0,28	2,50	0,70	1	

Special sizes and lengths up to 5.0 m on request.

aquatherm black system HEATING AND COOLING GRIDS

oxygen-tight (incl. fixing rails depending on the type of connection)

Attention:

All grids are available in the mentioned connection types at same prices.

Simply replace the first two figures of the article number („52”xxxx) with those of the required type of connection (i. e. „62” or „64”).

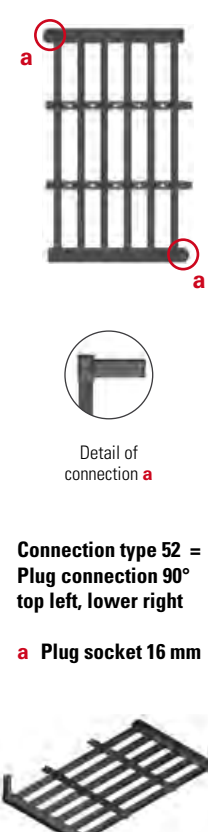
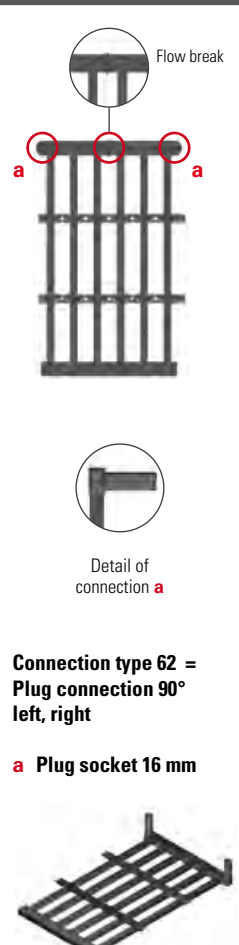
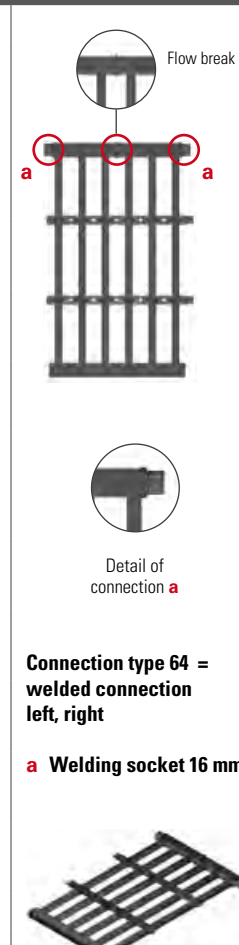
Connection types of the grids			Art. no.	Width [m]	Length [m]	Area [m ²]	PU	Price € pc
52	62	64						
 <p>Detail of connection a</p> <p>Connection type 52 = Plug connection 90° top left, lower right</p> <p>a Plug socket 16 mm</p>	 <p>Flow break</p> <p>Detail of connection a</p> <p>Connection type 62 = Plug connection 90° left, right</p> <p>a Plug socket 16 mm</p>	 <p>Flow break</p> <p>Detail of connection a</p> <p>Connection type 64 = welded connection left, right</p> <p>a Welding socket 16 mm</p>	52 32040	0,32	0,40	0,13	1	
			52 32050	0,32	0,50	0,16	1	
			52 32060	0,32	0,60	0,19	1	
			52 32070	0,32	0,70	0,22	1	
			52 32080	0,32	0,80	0,26	1	
			52 32090	0,32	0,90	0,29	1	
			52 32100	0,32	1,00	0,32	1	
			52 32120	0,32	1,20	0,38	1	
			52 32140	0,32	1,40	0,45	1	
			52 32160	0,32	1,60	0,51	1	
			52 32180	0,32	1,80	0,58	1	
			52 32200	0,32	2,00	0,64	1	
			52 32225	0,32	2,25	0,72	1	
			52 32250	0,32	2,50	0,80	1	
			52 36040	0,36	0,40	0,14	1	
			52 36050	0,36	0,50	0,18	1	
			52 36060	0,36	0,60	0,22	1	
			52 36070	0,36	0,70	0,25	1	
			52 36080	0,36	0,80	0,29	1	
			52 36090	0,36	0,90	0,32	1	
52 36100	0,36	1,00	0,36	1				
52 36120	0,36	1,20	0,43	1				
52 36140	0,36	1,40	0,50	1				
52 36160	0,36	1,60	0,58	1				
52 36180	0,36	1,80	0,65	1				
52 36200	0,36	2,00	0,72	1				
52 36225	0,36	2,25	0,81	1				
52 36250	0,36	2,50	0,90	1				

Special sizes and lengths up to 5.0 m on request.







aquatherm black system HEATING AND COOLING GRIDS

oxygen-tight (incl. fixing rails depending on the type of connection)

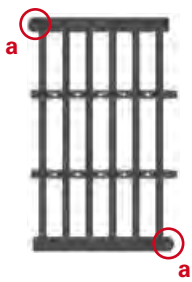
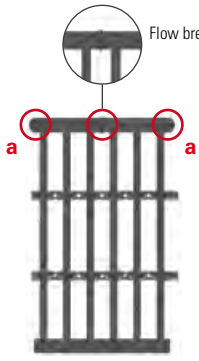
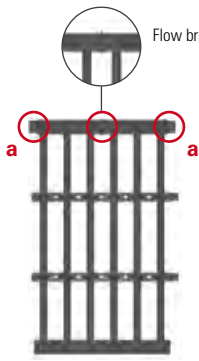
Attention:

All grids are available in the mentioned connection types at same prices.

Simply replace the first two figures of the article number („52“xxxx) with those of the required type of connection (i. e. „62“ or „64“).

Connection types of the grids			Art. no.	Width [m]	Length [m]	Area [m ²]	PU	Price € pc
52	62	64						
			5240040	0,40	0,40	0,16	1	
			5240050	0,40	0,50	0,20	1	
			5240060	0,40	0,60	0,24	1	
			5240070	0,40	0,70	0,28	1	
			5240080	0,40	0,80	0,32	1	
			5240090	0,40	0,90	0,36	1	
			5240100	0,40	1,00	0,40	1	
			5240120	0,40	1,20	0,48	1	
			5240140	0,40	1,40	0,56	1	
			5240160	0,40	1,60	0,64	1	
5240180	0,40	1,80	0,72	1				
5240200	0,40	2,00	0,80	1				
5240225	0,40	2,25	0,90	1				
5240250	0,40	2,50	1,00	1				
 <p>Detail of connection a</p>			 <p>Detail of connection a</p>			 <p>Detail of connection a</p>		
<p>Connection type 52 = Plug connection 90° top left, lower right</p> <p>a Plug socket 16 mm</p>			<p>Connection type 62 = Plug connection 90° left, right</p> <p>a Plug socket 16 mm</p>			<p>Connection type 64 = welded connection left, right</p> <p>a Welding socket 16 mm</p>		
			5248040	0,48	0,40	0,19	1	
			5248050	0,48	0,50	0,24	1	
			5248060	0,48	0,60	0,29	1	
			5248070	0,48	0,70	0,34	1	
			5248080	0,48	0,80	0,38	1	
			5248090	0,48	0,90	0,43	1	
			5248100	0,48	1,00	0,48	1	
			5248120	0,48	1,20	0,58	1	
			5248140	0,48	1,40	0,67	1	
			5248160	0,48	1,60	0,77	1	
5248180	0,48	1,80	0,86	1				
5248200	0,48	2,00	0,96	1				
5248225	0,48	2,25	1,08	1				
5248250	0,48	2,50	1,20	1				

Special sizes and lengths up to 5.0 m on request.







aquatherm black system HEATING AND COOLING GRIDS

oxygen-tight (incl. fixing rails depending on the type of connection)

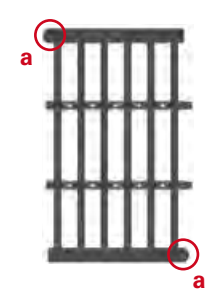
Attention:

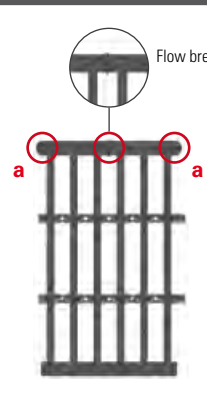
All grids are available in the mentioned connection types at same prices.

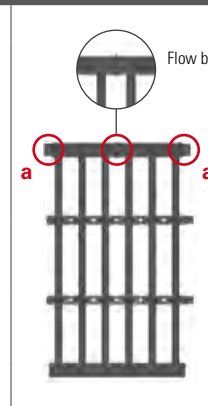
Simply replace the first two figures of the article number („52“xxxx) with those of the required type of connection (i. e. „62“ or „64“).

Connection types of the grids			Art. no.	Width [m]	Length [m]	Area [m ²]	PU	Price € pc
52	62	64						
  Detail of connection a Connection type 52 = Plug connection 90° top left, lower right a Plug socket 16 mm 	  Detail of connection a Connection type 62 = Plug connection 90° left, right a Plug socket 16 mm 	  Detail of connection a Connection type 64 = welded connection left, right a Welding socket 16 mm 	52 52040	0,52	0,40	0,21	1	
			52 52050	0,52	0,50	0,26	1	
			52 52060	0,52	0,60	0,31	1	
			52 52070	0,52	0,70	0,36	1	
			52 52080	0,52	0,80	0,42	1	
			52 52090	0,52	0,90	0,47	1	
			52 52100	0,52	1,00	0,52	1	
			52 52120	0,52	1,20	0,62	1	
			52 52140	0,52	1,40	0,73	1	
			52 52160	0,52	1,60	0,83	1	
			52 52180	0,52	1,80	0,94	1	
			52 52200	0,52	2,00	1,04	1	
			52 52225	0,52	2,25	1,17	1	
			52 52250	0,52	2,50	1,30	1	
			52 56040	0,56	0,40	0,22	1	
			52 56050	0,56	0,50	0,28	1	
			52 56060	0,56	0,60	0,34	1	
			52 56070	0,56	0,70	0,39	1	
			52 56080	0,56	0,80	0,45	1	
			52 56090	0,56	0,90	0,50	1	
52 56100	0,56	1,00	0,56	1				
52 56120	0,56	1,20	0,67	1				
52 56140	0,56	1,40	0,78	1				
52 56160	0,56	1,60	0,90	1				
52 56180	0,56	1,80	1,01	1				
52 56200	0,56	2,00	1,12	1				
52 56225	0,56	2,25	1,26	1				
52 56250	0,56	2,50	1,40	1				

Special sizes and lengths up to 5.0 m on request.







aquatherm black system HEATING AND COOLING GRIDS

oxygen-tight (incl. fixing rails depending on the type of connection)

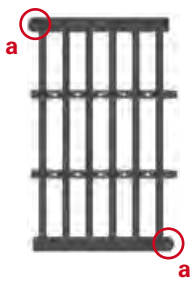
Attention:

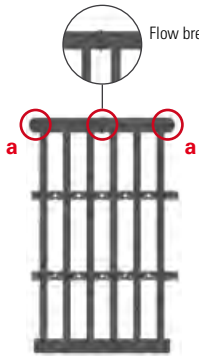
All grids are available in the mentioned connection types at same prices.

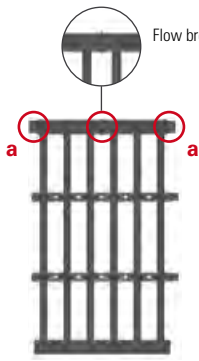
Simply replace the first two figures of the article number („52“xxxx) with those of the required type of connection (i. e. „62“ or „64“).

Connection types of the grids			Art. no.	Width [m]	Length [m]	Area [m ²]	PU	Price € pc
52	62	64						
  Detail of connection a Connection type 52 = Plug connection 90° top left, lower right a Plug socket 16 mm 	  Detail of connection a Connection type 62 = Plug connection 90° left, right a Plug socket 16 mm 	  Detail of connection a Connection type 64 = welded connection left, right a Welding socket 16 mm 	52 60040	0,60	0,40	0,24	1	
			52 60050	0,60	0,50	0,30	1	
			52 60060	0,60	0,60	0,36	1	
			52 60070	0,60	0,70	0,42	1	
			52 60080	0,60	0,80	0,48	1	
			52 60090	0,60	0,90	0,54	1	
			52 60100	0,60	1,00	0,60	1	
			52 60120	0,60	1,20	0,72	1	
			52 60140	0,60	1,40	0,84	1	
			52 60160	0,60	1,60	0,96	1	
			52 60180	0,60	1,80	1,08	1	
			52 60200	0,60	2,00	1,20	1	
			52 60225	0,60	2,25	1,35	1	
			52 60250	0,60	2,50	1,50	1	
			52 68040	0,68	0,40	0,27	1	
52 68050	0,68	0,50	0,34	1				
52 68060	0,68	0,60	0,41	1				
52 68070	0,68	0,70	0,48	1				
52 68080	0,68	0,80	0,54	1				
52 68090	0,68	0,90	0,61	1				
52 68100	0,68	1,00	0,68	1				
52 68120	0,68	1,20	0,82	1				
52 68140	0,68	1,40	0,95	1				
52 68160	0,68	1,60	1,09	1				
52 68180	0,68	1,80	1,22	1				
52 68200	0,68	2,00	1,36	1				
52 68225	0,68	2,25	1,53	1				
52 68250	0,68	2,50	1,70	1				

Special sizes and lengths up to 5.0 m on request.







aquatherm black system HEATING AND COOLING GRIDS

oxygen-tight (incl. fixing rails depending on the type of connection)

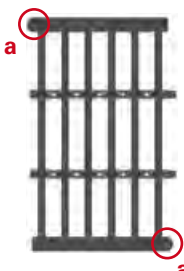
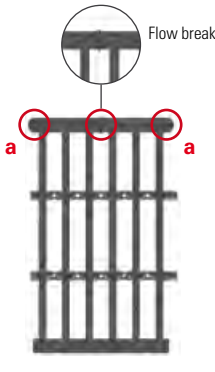
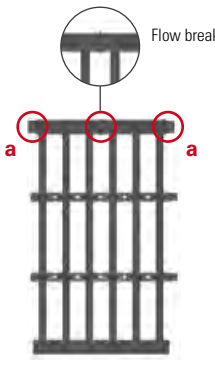
Attention:

All grids are available in the mentioned connection types at same prices.

Simply replace the first two figures of the article number („52“xxxx) with those of the required type of connection (i. e. „62“ or „64“).

Connection types of the grids			Art. no.	Width [m]	Length [m]	Area [m ²]	PU	Price € pc
52	62	64						
			52 80040	0,80	0,40	0,32	1	
			52 80050	0,80	0,50	0,40	1	
			52 80060	0,80	0,60	0,48	1	
			52 80070	0,80	0,70	0,56	1	
			52 80080	0,80	0,80	0,64	1	
			52 80090	0,80	0,90	0,72	1	
			52 80100	0,80	1,00	0,80	1	
			52 80120	0,80	1,20	0,96	1	
			52 80140	0,80	1,40	1,12	1	
			52 80160	0,80	1,60	1,28	1	
52 80180	0,80	1,80	1,44	1				
52 80200	0,80	2,00	1,60	1				
52 80225	0,80	2,25	1,80	1				
52 80250	0,80	2,50	2,00	1				
								
								
								
<p>Detail of connection a</p>			<p>Detail of connection a</p>			<p>Detail of connection a</p>		
<p>Connection type 52 = Plug connection 90° top left, lower right</p>			<p>Connection type 62 = Plug connection 90° left, right</p>			<p>Connection type 64 = welded connection left, right</p>		
<p>a Plug socket 16 mm</p>			<p>a Plug socket 16 mm</p>			<p>a Welding socket 16 mm</p>		
			52 00040	1,00	0,40	0,40	1	
			52 00050	1,00	0,50	0,50	1	
			52 00060	1,00	0,60	0,60	1	
			52 00070	1,00	0,70	0,70	1	
			52 00080	1,00	0,80	0,80	1	
			52 00090	1,00	0,90	0,90	1	
			52 00100	1,00	1,00	1,00	1	
			52 00120	1,00	1,20	1,20	1	
			52 00140	1,00	1,40	1,40	1	
			52 00160	1,00	1,60	1,60	1	
52 00180	1,00	1,80	1,80	1				
52 00200	1,00	2,00	2,00	1				
52 00225	1,00	2,25	2,25	1				
52 00250	1,00	2,50	2,50	1				

Special sizes and lengths up to 5.0 m on request.

aquatherm black system HEATING AND COOLING GRID FOR CEILING PANELS*retractable, oxygen-tight, with one-side 90° plug connection and flow break*

Art. no.	Dimension grid	Dimension ceiling panel	PU	Price € pc
6256060	56x60cm = 0,34m ²	62,5x62,5cm	1	
6256118	56x118cm = 0,66m ²	62,5x125cm	1	

Forced flow by in-centre welded blind plug in the main pipe, which offers a one-side connection of the grids among each other.

Special size on request!

**aquatherm black system PP-GRID CONNECTION PIPE***with oxygen barrier*

Art. no.	Dimension [mm]	Length [m]	PU	Price € m
81006	16	4	100	
81008	20	2,5	50	

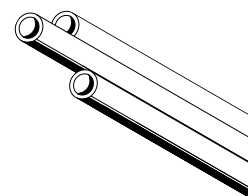
**aquatherm black system PP-GRID CONNECTION PIPE***with oxygen barrier, in ring*

Art. no.	Dimension [mm]	PU	Price € m
81026	16	100	
81028	20	100	

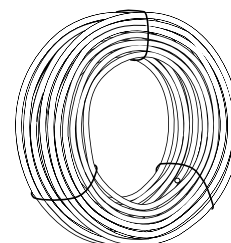
**aquatherm black system CORRUGATED CONNECTING PIPE***with oxygen barrier, in ring*

Art. no.	Dimension	PU	Price € m
81039		50	

Connectable by welding with Art. 81288, 81290, 81291 separable every 50 cm

**aquatherm black system CORRUGATED CONNECTING PIPE***with oxygen barrier, for connection types 52, 62 and 64*

Art. no.	Dimension	PU	Price € pc
81031	50 cm 1 x plug elbow 90° and welding socket 16 mm	1	
81032	50 cm with 2 x plug elbow 90°	1	
81035	150 cm with 2 x plug elbow 90°	1	
81038	100 cm with 2 x plug elbow 90°	1	
81044	50 cm with 2 x welding elbow 90°	1	
81047	100 cm with 2 x welding elbow 90°	1	
81048	150 cm with 2 x welding elbow 90°	1	
81049	50 cm with 1 x welding elbow 90° and 1 x welding socket 16 mm	1	

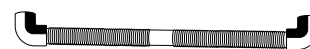
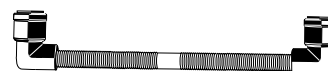

PLASTIC PIPE CLAMPS

Art. no.	For pipe dimension [mm]	PU	Price € pc
60716	16	50	
60720	20	50	

Colour: anthracite

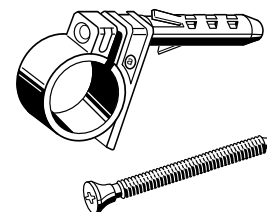
**aquatherm black system SOCKET**

for heating and cooling grids

Art. no.	Dimension [mm]	PU	Price € pc
81050	16	10	

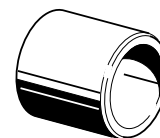
**aquatherm black system ELBOW 90°**

for heating and cooling grids

Art. no.	Dimension [mm]	PU	Price € pc
81060	16	10	

**aquatherm black system END CAP**

for heating and cooling grids

Art. no.	Dimension [mm]	PU	Price € pc
81080	16	10	

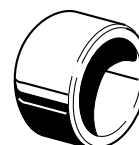
**aquatherm black system PP-R MALE END PLUG**

for heating and cooling grids (for old type of connection 50)

Art. no.	Dimension [mm]	PU	Price € pc
81092	16	10	

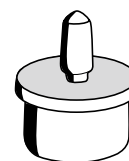
**aquatherm black system ELBOW 90°**

male/female

Art. no.	Dimension [mm]	PU	Price € pc
81065	16	10	

**aquatherm black system MAGNET HOLDER**

Art. no.	Dimension	PU	Price € pc
81286		50	

**GRID FIXING IN METAL CEILINGS WITH HOLDING-DOWN MAGNET**

aquatherm black system heating and cooling grids are connected with the metal ceiling plate by special custom-made holding-down magnets. The magnets guarantee a safe fixing and the optimum heat conducting connection between heating- and cooling grids and the metal panel. The fixing of heating- and cooling grids with holding-down magnets is performed after inserting the grids into the metal panel plates during the ceiling mounting at site. The demand for holding-down magnets depends on the dimension of the metal panel, basically plan with approx. 4 magnets per square meter.

Adhesive and solvent for sticking the aquatherm grids into metal ceiling panels can directly be bought at the manufacturer Wakol GmbH (www.wakol.de). The manufacturer's instructions are to be considered!

Article description adhesive: L1720 ROT

Article description solvent: Löser 31



aquatherm black system FIXING RAIL*for heating and cooling grids*

Art. no.	Dimension	PU	Price € pc
81506	Length = aqt black system 24 cm	10	

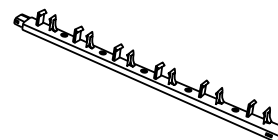
**aquatherm black system WALL BRACKET***for heating and cooling grids at wall heating- and cooling systems for drywall*

Art. no.	Dimension	PU	Price € pc
81296		10	

**aquatherm black system FIXING RAIL FOR DRY WALL***for heating and cooling grids*

Art. no.	Dimension	PU	Price € pc
81297		10	

Please note, when ordering the fixing rail for drywall Art. no. 81297, that for each rail two connection plugs with the Art. no. 81301 have to be ordered.

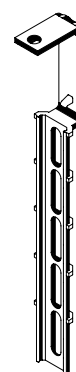
**aquatherm black system CONNECTING PLUG**

Art. no.	PU	Price € pc
81301	1	

In connection with Art. no. 81297 for fixing the heating-cooling grids in case of ceiling system with metal substructure.

In connection with Art. no. 81304 (perforated tape) for fixing the heating-cooling grids in case of wall systems with metal substructure.

**aquatherm black system MAGNET CLIP**

Art. no.	PU	Price € pc
81302	50	

In connection with art. no. 81506 for fixing the heating-cooling grids in case of ceiling systems with metal substructure.

**aquatherm black system PERFORATED TAPE**

Art. no.	Dimension	PU	Price € pc
81304	10 m x 19 mm	1	

In connection with art. no. 81301 for fixing the heating-cooling grids in case of wall systems with metal substructure.

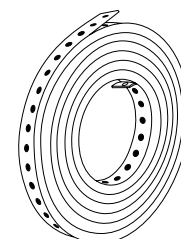

aquatherm black system FIXING CLAMP WITH WALL PLUG*for wall and ceiling installation*

Art. no.	Dimension	PU	Price € pc
81298		10	

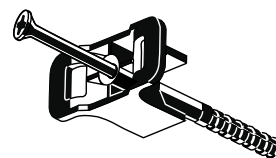
**aquatherm black system THERMOGRAPHY FILM***place at the wall for indicating the position of the pipe by colour changing*

Art. no.	Dimension [mm]	PU	Price € pc
50186	160x70	1	

**aquatherm black system CONNECTOR***one-sided pushfit connection/one-sided PP-R 16 mm*

Art. no.	Dimension [mm]	PU	Price € pc
81288	16	20	

with safety pin

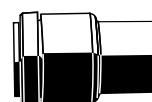
**aquatherm black system 90° ELBOW-ADAPTER***onesided plugable/onesided PP-R 16 mm weldable*

Art. no.	Dimension [mm]	PU	Price € pc
81290	16	10	

with safety pin

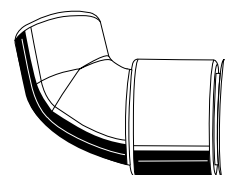
**aquatherm black system 45° ELBOW-ADAPTER***onesided plugable/onesided PP-R 16 mm weldable*

Art. no.	Dimension [mm]	PU	Price € pc
81291	16	10	

with safety pin

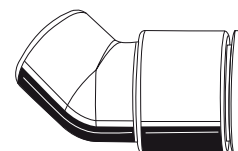
**aquatherm black system SEALING PLUG***for wall and ceiling grids*

Art. no.	Dimension [mm]	PU	Price € pc
81091	12	10	

welding tool for sealing plug Art. no. 50285 see tools

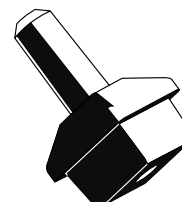
**aquatherm black system WELDING TOOL**

Art. no.	Dimension [mm]	PU	Price € pc
50285	12x12	1	

for sealing plug Art. no. 81091

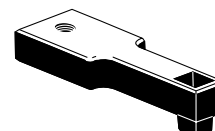

aquatherm black system TRANSITION ADAPTER

Art. no.	Dimension	PU	Price € pc
81097	aquatherm black system with press connection	10	

e.g. for connecting existing metal pipes

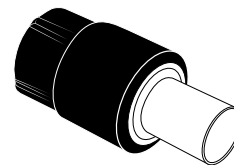
**aquatherm black system TRANSITION ADAPTER**

Art. no.	Dimension	PU	Price € pc
81292	aquatherm black system to aquatherm orange system 16 mm	10	

The adapter can be connected by the known sliding sleeve technology with the aquatherm black system.

**STARTER KIT SHOWER**

consists of:

Art. no.	Quantity	No.	Description	PU	Price € pc
81800	2 pieces	6424160	grids 24 x 160 cm	1	
	1 piece	6460160	grids 60 x 160 cm		
	4 pieces	81006	OT pipe 16 x 2,0 mm; length 2,0 m		
	10 pieces	81050	socket 16 mm		
	10 pieces	81060	elbow 90° 16 mm		
	10 pieces	60716	fixing clamp 16 mm		
	3 pieces	81296	wall bracket		
	3 pieces	81301	connecting plug		
	10 pieces	81298	fixing clamp with wall plug		





aquatherm control components

FOR AQUATHERM BLACK SYSTEM AND AQUATHERM ORANGE SYSTEM

The aquatherm radio control system combines latest Smart Home and IoT technology for all building types. The intelligent control technology communicates radio-controlled between the central radio unit, room thermostats and radio control distributors. The system is used to control the aquatherm surface heating and cooling systems. In case of cooling, dew point monitoring is realized by means of room thermostat with integrated hygrostat and external temperature sensor.

An integrated WiFi module provides access via smartphone or tablet. Thus, the heating and cooling system can be constantly monitored and adjusted.

The entire system is completed by the aquatherm heating and cooling circuit distributors. aquatherm heating and cooling circuit distributors enable an individual adjustment of volume flows via regulating valves. The distributors are delivered in a pre-assembled and ready-to-connect version.

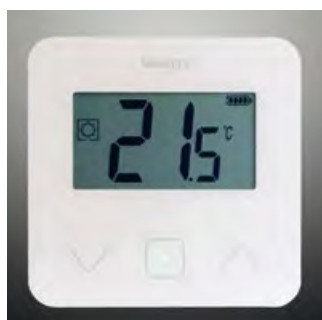

Radio room thermostat

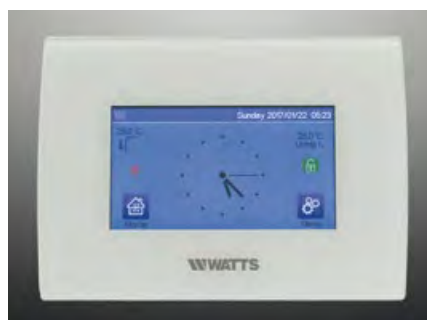

Central control with touch screen display



Control distributor

NEW aquatherm HEATING CIRCUIT MANIFOLD WITH FLOW INDICATOR*screwed joints and ball valves have to be ordered separately*Systems: **aquatherm orange system,**
aquatherm black system

Art. no.	Dimension	PU	Price € pc
94402	Stainless steel 2-fold flow indicator	1	
94403	Stainless steel 3-fold flow indicator	1	
94404	Stainless steel 4-fold flow indicator	1	
94405	Stainless steel 5-fold flow indicator	1	
94406	Stainless steel 6-fold flow indicator	1	
94407	Stainless steel 7-fold flow indicator.	1	
94408	Stainless steel 8-fold flow indicator	1	
94409	Stainless steel 9-fold flow indicator	1	
94410	Stainless steel 10-fold flow indicator	1	
94411	Stainless steel 11-fold flow indicator	1	
94412	Stainless steel 12-fold flow indicator	1	

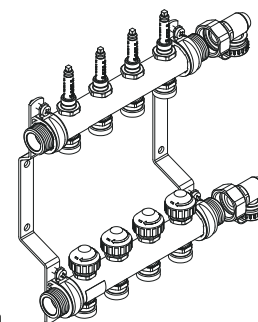
Sta
properues: ving

- Flow- and return manifold are arranged separately
- Flow indicator with shut-off in the flow
- Control and shut-off valve with protection cap in return
- Feed and drain valves
- Air valves
- Bracket set with bow and sound protection
- Sealing plug

NEW aquatherm BALL VALVE SETSystems: **aquatherm orange system,**
aquatherm black system

Art. no.	Dimension	PU	Price € pc
94413	1" x 1"	1	

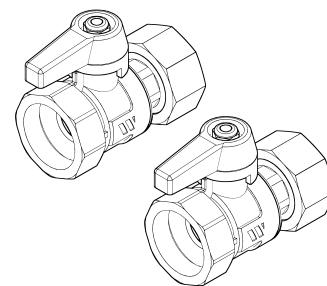
**NEW aquatherm BALL VALVE SET***Corner design*Systems: **aquatherm orange system,**
aquatherm black system

Art. no.	Dimension	PU	Price € pc
94414	1" x 1"	1	

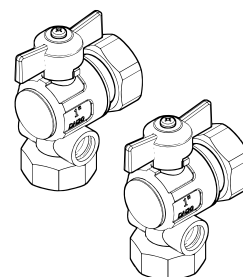
**NEW aquatherm LINE CONTROL VALVE SET FOR MANIFOLD**Systems: **aquatherm orange system,**
aquatherm black system

Art. no.	Dimension	PU	Price € pc
94415	1"M	1	

For restriction of flow rate respectively for hydraulic balancing of manifolds

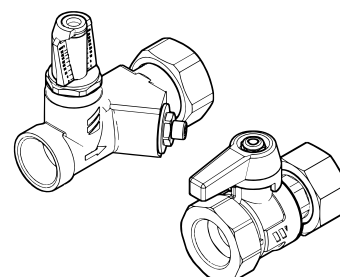
**NEW aquatherm HEATING CIRCUIT MANIFOLD EXTENSION SET***for Art. no. 94402 – 94412*Systems: **aquatherm orange system,**
aquatherm black system

Art. no.	Dimension	PU	Price € pc
94416		1	

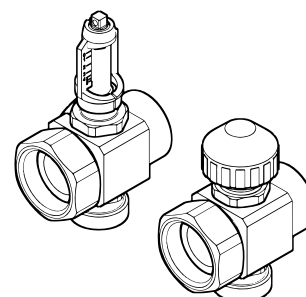

aquatherm EUROCONUS CONNECTOR*for heating circuit manifold*

Systems: **aquatherm orange system,**
aquatherm black system

Art. no.	Dimension [mm]	PU	Price € pc
92106	for 16 x 2,0 mm pipe	2	
92107	for 17 x 2,0 mm pipe	2	
92108	for 20 x 2,0 mm pipe	2	

cap nut nickel-plated

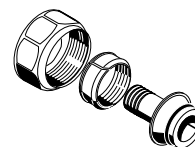
**aquatherm ACTUATOR***for heating circuit manifolds and heating circuit control valves – flow*

Systems: **aquatherm orange system,**
aquatherm black system

Art. no.	Dimension	PU	Price € m/pc
94102	230V	1	
94103	24V	1	

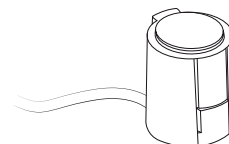
**NEW aquatherm CENTRAL RADIO UNIT***with 4,3" touchscreen*

Systems: **aquatherm orange system,**
aquatherm black system

Art. no.	Dimension	PU	Price € m/pc
94417		1	

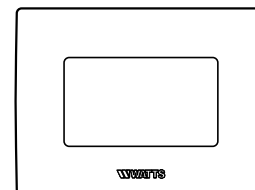

- remote access via app or web
- intuitive operation: plug & play
- wall mounting with power supply 85-265 VA (50-60Hz) or via mini USB cable
- table installation with stand
- heating-cooling units controllable

NEW aquatherm RADIO ROOM THERMOSTAT*with glass touchscreen*

Systems: **aquatherm orange system,**
aquatherm black system

Art. no.	Dimension	PU	Price € m/pc
94418		1	

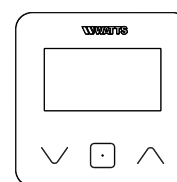

- heating or heating/cooling
- setting of different temperature modes
- antifreeze protection function
- pincode and anti-theft protection
- wall or table installation
- "open window" detection

NEW aquatherm RADIO ROOM THERMOSTAT*digital, with LCD-display, programmable*

Systems: **aquatherm orange system,**
aquatherm black system

Art. no.	Dimension	PU	Price € pc
94419		1	

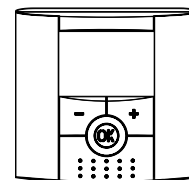
**NEW aquatherm RADIO ROOM THERMOSTAT***digital, with LCD-display, programmable, with hygrostat*

Systems: **aquatherm orange system,**
aquatherm black system

Art. no.	Dimension	PU	Price € pc
94420		1	
1			

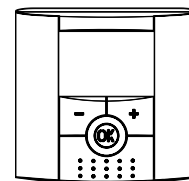
**NEW aquatherm RADIO CONTROL DISTRIBUTOR***Master, for 6 zones*

Systems: **aquatherm orange system,**
aquatherm black system

Art. no.	Dimension	PU	Price € pc
94422		1	

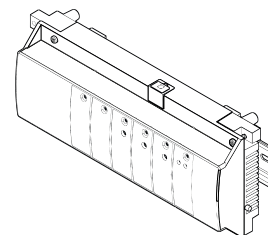

- Zone control for water-bearing surface heating/cooling
- up to 10 zones (room sensor)
- Switching output for pump and heat generator by radio or cable (potential free)

NEW aquatherm RADIO CONTROL DISTRIBUTOR 4-FOLD*Extension for 4 zones*

Systems: **aquatherm orange system,**
aquatherm black system

Art. no.	Dimension	PU	Price € pc
94423		1	

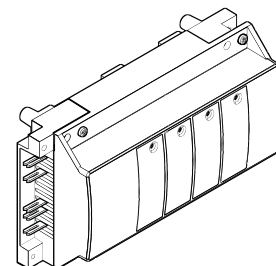

NEW aquatherm MANAGEMENT MODULE*for heating/cooling*Systems: **aquatherm orange system,**
aquatherm black system

Art. no.	Dimension	PU	Price € pc
94421		1	

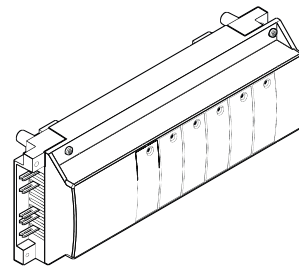

- Control and management for water-bearing surface heating/cooling in conjunction with control distributor
- signal for central heating/cooling changeover via floating switching output

NEW aquatherm SINGLE RADIO RECEIVER*for control of surface heating/cooling*Systems: **aquatherm orange system,**
aquatherm black system

Art. no.	Dimension	PU	Price € pc
94424		1	

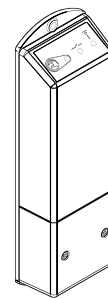
**NEW aquatherm RADIO REPEATER***to expand the radio transmission area or Erweiterung des Funk-Übertragungsbereiches*Systems: **aquatherm orange system,**
aquatherm black system

Art. no.	Dimension	PU	Price € pc
94425		1	

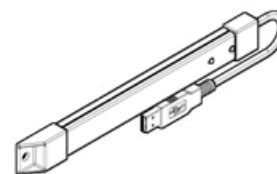
**NEW aquatherm DEWPOINT SENSOR***3 metres*Systems: **aquatherm orange system,**
aquatherm black system

Art. no.	Dimension	PU	Price € pc
94426		1	

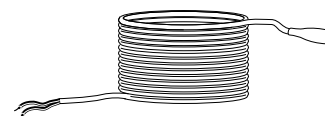

TERMS AND CONDITIONS

Important note regarding our sales, warranty and delivery conditions:

Our sales and delivery conditions (issue: 2014) as well as the contact details of our technical sales department and our representatives can be found on our website www.aquatherm.de.

Errors, misprints and technical modifications reserved. With the appearance of this catalogue all previous issues become void.

aquatherm GmbH, 2020. This technical information is protected by copyright. Reproductions are prosecuted.



Management
System
ISO 9001:2015
ISO 14001:2015
ISO 50001:2011
www.tuv.com
ID 0091005348

aquatherm GmbH

Biggen 5 | 57439 Attendorn | Germany | Tel.: +49 2722 950 0
info@aquatherm.de | www.aquatherm.de

Официальный представитель завода: Группа Компаний Агпайп
WWW.AGPIPE.RU +7 (495) 928-0008 INFO@AGPIPE.RU

Order-No.: E97060
Edition: 4.2020

aquatherm black system - Surface heating and cooling system Applications: Ceiling, wall, floor